

MPT-51610 Belt Sander (10*330mm)

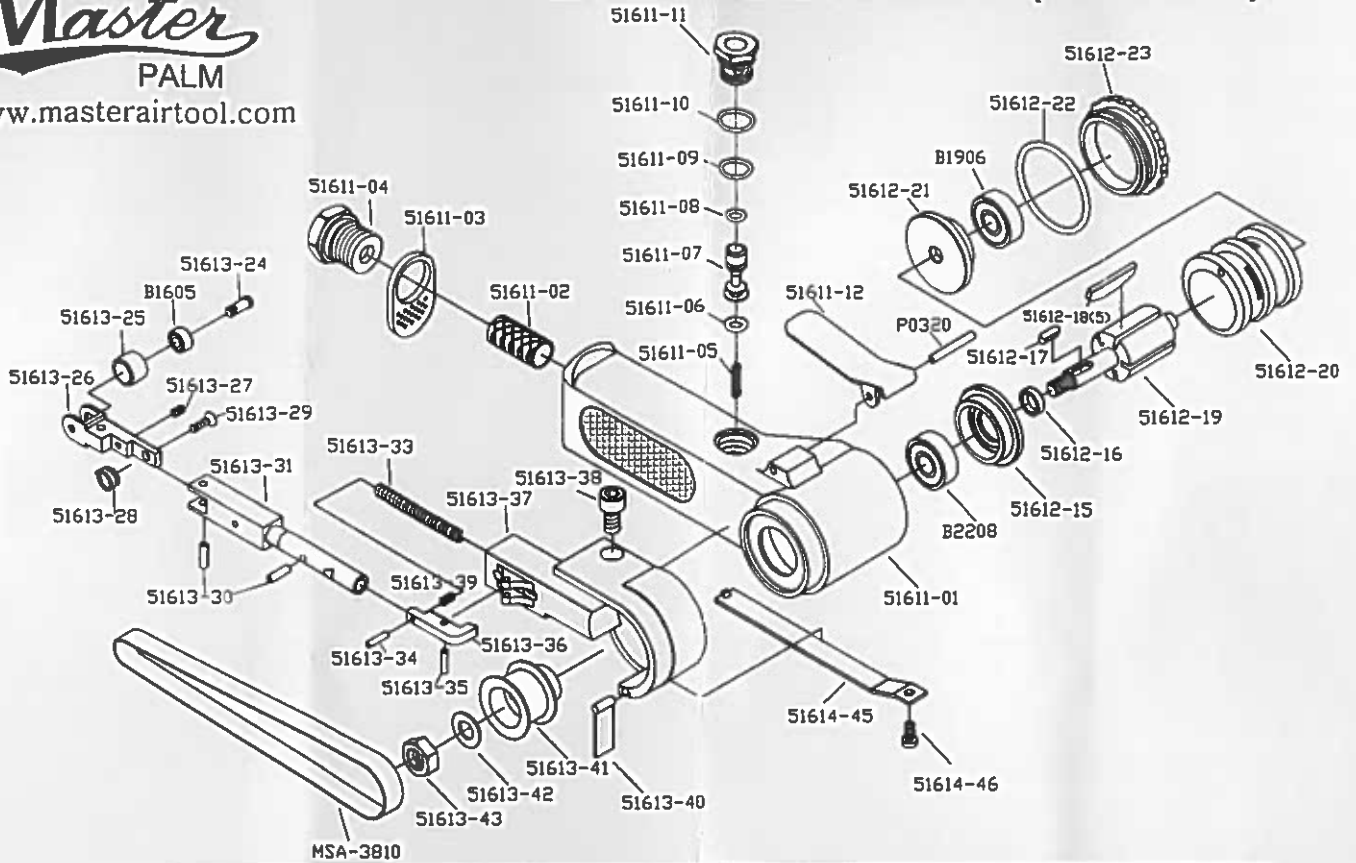

DESCRIPTION	PARTS NO.	DESCRIPTION	PARTS NO.
MOTOR HOUSING	51611-01	IDLE PULEY SHAFT 10	51613-24
VALVE BUSHING	51611-11	BEARING	B1605
O-RING	51611-10	IDLE PULEY 10 ASSY	51613-25
THROTTLE VALVE	51611-07	BRACKET 10	51613-26
O-RING	51611-09	SCREW	51613-27
O-RING	51611-06	SCREW	51613-28
VALVE SPRING	51611-05	SPRING	51613-29
O-RING	51611-08	TENSION BAR	51613-31
THROTTLE LEVER	51611-12	SPRING PIN (2)	51613-30
SPRING PIN	P0320	SPRING	51613-33
EXHAUST SLEEVE	51611-03	PIN	51613-34
INLET BUSHING	51611-04	PIN	51613-35
SPRING	51611-02	TENSION BAR LEVER	51613-36
BALL BEARING	B2208	GUARD SUB ASSY	51613-37
FRONT END PLATE	51612-15	SET SCREW	51613-38
BALL BEARING	B1906	SCREW	51613-39
REAR END PLATE	51612-21	DUST COVER	51613-40
ROTOR KEY	51612-17	DRIVER PULLEY	51613-41
CYLINDER	51612-20	WASHER	51613-42
ROTOR	51612-19	SET NUT	51613-43
ROTOR BLADE (5)	51612-18	SHOE 10	51613-45
WASHER	51612-16	SCREW	51613-46
O-RING	51612-22	BELT SANDER PAPER	MSA-3810
MOTOR CLAMP	51612-23		