



ITM®



2026 CATALOG

"ANYTHING THAT MAKES A HOLE"®



CONSTRUCTION DRILLING AND CUTTING SOLUTIONS

WWW.ITMTOOLS.COM | (800) 247-5696 | SALES@ITMTOOLS.COM



100% LAB TESTED

FAST DELIVERY

4000 items. Orders are shipped the same day if received before 3 P.M. Eastern Time.

EASY ORDERING

Order toll free, by fax, or email, either by part number or description. Our staff will quickly help you decide which product best fits your application. Order what you need, there is never a minimum order.

COMPLETE SATISFACTION

Simple: all of your purchases must satisfy you completely, or we will issue you a refund, exchange, or credit.

ITM catalogs are always made with YOU in mind! You will find our catalog easy to use and our staff a valuable resource for your business.

Thank you for your business and patronage.

Call us. We will make your job a little bit easier.

Sincerely yours,

Berardo Paradiso
President - ITM Corp.

Alberic
Alberic Paradiso

Bryan Markell
Bryan Markell

Jacob Bial
Jacob Bial

Chun Keat
Chun Keat

Marilyn Rodriguez
Marilyn Rodriguez

Annette Kempadoo
Annette Kempadoo



p.11 Two Tone Jobbers HSS 118° Point



p.11 Bright Finish Jobbers HSS 118° Point



p.11 Black Oxide Jobbers HSS 118° Point



p.12 Black Oxide Jobbers HSS 135° Split Point



p.12 Black Oxide Wire Gauge HSS 135° Split Point



p.13 Black Oxide Letter HSS 135° Split Point



p.13 Black Oxide Metric HSS 118° Point



p.14 Black Oxide Stub Length HSS 135° Split Point



p.15 Black Oxide Silver & Deming HSS 118° Point

BLACK
Oxide



p.17 Black & Gold Jobbers HSS 135° Split Point



p.17 Black & Gold Wire Gauge HSS 135° Split Point



p.18 Black & Gold Mechanics Length HSS 135° Split Point



p.18 Black & Gold Letter Size HSS 135° Split Point



p.19 1/4" Hex Impact Black & Gold Jobbers HSS 135° Split Point



p.19 Black & Gold Silver & Deming HSS 118° Split Point



p.20 MRO Black & Gold Jobbers 135° Split Point



p.20 MRO Black & Gold Letter Size HSS 135° Split Point



p.21 MRO Black & Gold Wire Gauge 135° Split Point

BLACK-GOLD



p.22 Cobalt Jobbers 135° Split Point



p.22 Cobalt Wire Gauge 135° Split Point



p.23 Cobalt Stub Length 135° Split Point



p.23 Cobalt Silver & Deming 118° Split Point

COBALT



p.24 Titanium (TiN) Jobbers HSS 135° Split Point



p.24 1/4" Hex Impact Titanium (TiN) Jobbers



HSS 135° Split Point



p.25 Parabolic Jobbers 135° Split Point



p.25 Cobalt Jobbers 135° Split Point

TITANIUM



p.26 Spotweld Double End



p.26 Double End Drills - Sheet Metal Drills



p.26 VIP Step Jobbers HSS - Sheet Metal Drills



p.27 Aircraft HSS 135° Split Point (6", 12" & 18" Long)



p.28 Tap & Drill Sets / 525 Pc. Dispenser



p.29 Bullet Case Drill Bit Sets / HUOT Case Drill Bit Sets





Bar Champ Outer Reamer	p.30	
Hand Tap Wrenches	p.33	
Hand Taps, HSS	p.33	
Combo Drill Taps	p.34	
Spiral Point (Gun) Taps	p.34	
3 in 1 Combo Drill Taps	p.35	
Pipe Taps, NPT	p.36	
Countersinks - Zero Flute Countersinks	p.37	
Rim Champ Inner Reamer	p.37	
Screw Extractor	p.37	
Burs - Solid Carbide / Kit	p.38	
Step Drills Fast Spiral - HSS - TiAIN	p.40	
Reamers	p.42	
Annular Twist Drill HSS	p.44	
Annular Cutters HSS / Kit	p.45	
Step Reamers / Kit	p.46	
Magnetic Drill Accessories Magnet, Countersinks & Chucks	p.47	
T.C.T. Hole Cutters	p.48	
Hole Saws - Carbide Tipped	p.50	
Hole Saws - Bi-Metal	p.51	
Arbors and Pilot Drills	p.53	
Metal Cutting Blades - Carbide	p.54	
Porta Band Saw Blades - Bi-Metal	p.56	



p.57 Reciprocating Blades - Bi-Metal - Wood & Metal - Bulk Packs



p.58 Reciprocating Blades - Bi-Metal - Retail Ready Packs
Wood & Metal, Heavy Metal and Carbide



p.60 Reciprocating Blades - Bi-Metal - Heavy Duty - Demolition



p.60 Reciprocating Blades - 18" Long Demo DECAPITATOR



p.61 Hack Saw Blades - Bi-Metal



p.62 Oscillating Blades - Bi-Metal



p.64 Wire Brushes



p.66 Bell Hanger Drills (Fish Hole Drills)
HSS & Carbide Tipped



p.66 Brad Point Wood Drills



p.67 Electrician's Flex Bit (Stretch Bit)



p.67 Circular Saw Blades - Wood



p.68 Long Boy Drills HSS (12" & 18")



p.68 Drywall Cutter



p.69 Self Feed (Multispur) Wood Drills



p.69 Extensions (For Ship Augers/Self Feed)



p.70 Spade Wood Drills - Self Feed



p.71 Self Feed Twister



p.71 Carbide Tipped Hole Saw
- **The Butcher**



p.72 Power Pole Auger Drills



p.72 Lineman Pole Auger Drills



p.73 Ship Auger Wood Drills



p.74 V Groove Tile Bit



p.75 V Groove Diamond
Tile Blade

p.75 Double Sided Diamond
Cutting/Grinding Disc



p.76 White Diamond Tile Bit

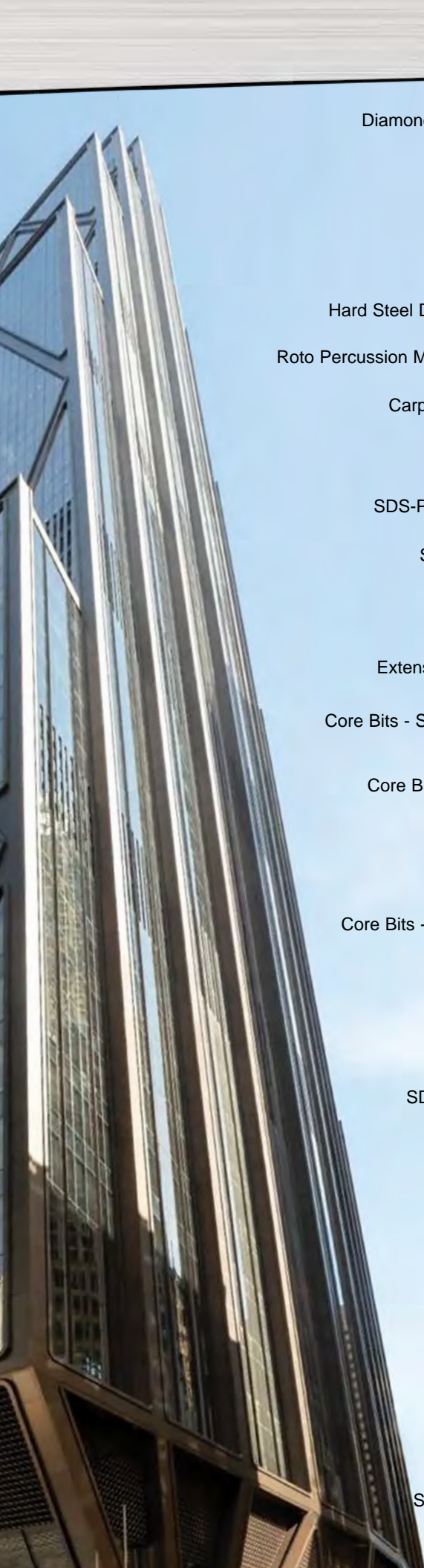

Diamond Milling & Countersinks	p.77		NEW!
Glass Drills	p.78		
Blu Diamond Tile Bit	p.78		
Multi Purpose Drills	p.79		NEW!
Hard Steel Drills - Left & Right Hand	p.79		
Roto Percussion Masonry Drills - Standard	p.80		
Carpet Tack Strip Stub Drills	p.80		
SDS-PLUS - REDLINE	p.81		
SDS-PLUS - BOHR HAMMER	p.82		
SDS-PLUS - X-CUTTER	p.86		NEW!
SDS-MAX - X-CUTTER	p.88		
Extension Systems / Adapters	p.89		
Core Bits - SDS-MAX - Taper Shank	p.90		
Core Bits - SDS-MAX - 1 Piece	p.91		
SDS-MAX Tunnel Bore	p.91		
Core Bits - SDS-MAX Ratio Shank	p.92		
Core Bits - SDS-PLUS	p.92		NEW!
SDS-PLUS Diamond Core	p.93		
Dry Diamond Core Stone Countertops	p.94		NEW!
Wet Diamond Core	p.95		NEW!
Duster Rotary Hammer	p.96		
Dust Pro Cups	p.97		
SDS-PLUS Stop Bit	p.98		
SDS-PLUS Anchor Driver	p.98		NEW!



p.98 SDS-MAX to SDS-PLUS Adapter



p.99 Concrete Screw Drills



p.99 SDS-PLUS HEX for Concrete Screws



p.99 Concrete Screw Sleeve / Concrete Screw Kit



p.100 Rebar Cutters - Impact & Rotary Only - SDS-PLUS & SDS-MAX

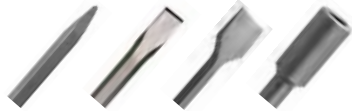

p.102 SDS-MAX - SDS-PLUS - SDS-PLUS MINI Chisels



p.104 PCD Cup Wheel - Diamond Grinding Cup Wheel



p.105+ Diamond Cutting Wheels And Tuck Points



p.109+ Screwdrivers and Insert Bits



p.114 Insert Bits - TIC TAC and KEYCHAIN



p.116 Bit Holders



p.118 Sockets (Magnetic Impact) & Drivers



p.119 Nut Setters - Magnetic / Impact Protection



p.120 Insert Bit Sets & MEGAPRO Screwdriver



p.122 Cable Ties



p.123 Plastic Anchor Kits & Zap In Anchors



p.124 Utility Knives and Accessories



p.125+ Retail Ready Displays / Standard Displays



expertise

because drilling solutions



can be out of the ordinary

Terms Of Sale

- Terms:** 2% 10 Days, Net 30 Days. All credit cards welcome.
- Credit:** Open account privileges are extended to any firm that is satisfactorily rated. New accounts should submit at least 3 commercial references including all contact information and their tax resale number.
- Quantities:** Although there is no minimum purchase order, we reserve the right to adjust any order to the minimum packaged quantities indicated in catalog.
- Claims:** Should be made within 15 days of receipts.
- Freight:** Prepaid for NET invoices equaling \$600 or more.

EFFECTIVE JANUARY 2026.





HSS TOOL DATA

Suggested Drill Bits To Be Used For Various Types Of Materials:

MATERIAL	DRILL STYLE	ANGLE POINT	PRESSURE TO APPLY	COOLANT OR LUBRICANT
CARBON STEEL DUCTILE STEEL BRASS BRONZE	GENERAL PURPOSE DRILLS	118° POINT	MEDIUM TO HEAVY	OIL or WATER SOLUTION
CARBON STEEL ALUMINUM AUSTENITIC STAINLESS STEEL	HEAVY DUTY AND TITANIUM	135° SPLIT POINT	MEDIUM TO HEAVY	OIL or ACTIVATED SOLUTION
STAINLESS STEEL SERIES C CAST IRON	COBALT DRILLS	135° SPLIT POINT	MEDIUM TO HEAVY	OIL or ACTIVATED SOLUTION
HARD STEEL HEAT TREATED ALLOYS	HARD BODY CARBIDE TIPPED AND COBALT	130° & 135° SPLIT POINT	HEAVY	OIL or ACTIVATED SOLUTION

Chemical Analysis Of The Three Primary High Speed Steels Used To Manufacture HSS Drill Bits:

TYPE	CHEMICAL COMPOSITION						ROCKWELL C HARDNESS	TERM
	CARBON	TUNGSTEN	MOLYBDENUM	CHROMIUM	VANADIUM	COBALT		
M2	0.85	6.00	5.00	4.00	1.90	-	63-65	HSS
M35	1.10	1.50	9.50	1.15	1.15	5.00	65-67	COBALT
M42	1.10	1.50	9.50	1.15	1.15	8.00	65-67	SUPER COBALT

M2 "HSS" is the standard material used for all **ITM** drill bits. M2 has good red-hardness and retains its cutting edge longer than other general purpose high speed steels because of its increased quantity of tungsten (dull red heat up to 1000° F without loss of hardness or rapid dulling of cutting edge).

M2 is generally favored for high production machine work.

M35 M35 is the standard cobalt material used for most **ITM** cobalt drill bits. M35 has excellent resistance to abrasion and very good red-hardness for working difficult materials.

M42 M42 "Super Cobalt" is American made premium cobalt material used for higher performance **ITM** cobalt drill bits. M42 has the best resistance to abrasion and red-hardness.

COBALT DRILLS

Made of the finest Cobalt steel obtainable and furnished with a 135° split point, these drills are designed for use in machining hard, tough materials beyond the normal cutting capabilities of regular high speed steel tools. These include work-hardening grades of stainless steels, titanium, high temperature alloys, and many other heat treated materials. In addition, due to their resistant properties, they can also be used at higher speeds to drill abrasive plastics, cast iron, and other types of difficult to machine work materials.



Always Use Protection When Drilling.

Always Use High RPM For Smaller Diameters and Lower RPM For Larger Diameters.

HSS TOOL DATA

Understanding High Speed Steel Drill Bits:

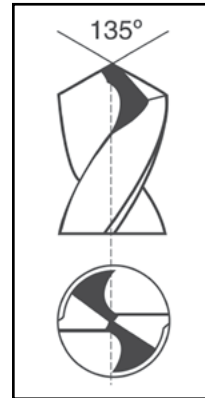
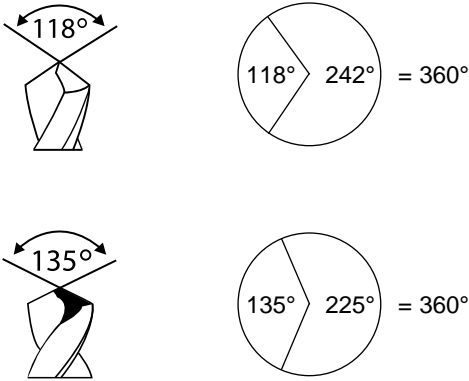

Split Point

An extra cutting angle on the 2 cutting edges of a drill bit.

Split Point is designated here in black.

Split Pointing is almost always reserved for 135° HSS drill bits.

118° drill bits have a sharp point and are common on standard / general purpose drill bits where light duty work is needed. Because of this sharp point, 118° drill bits will tend to “walk” or spin like a top on flat surfaces. This is why a centering drill or center punch is normally used to start off holes. If the operator has very steady hands, then the 118° drill bit can be used without center punching.

135° drill bits have a flatter point which gives the drill bit more cutting surface area. When more surface area cuts the steel, drilling is faster.



Understanding Nomenclature Vis-a-vis Size:

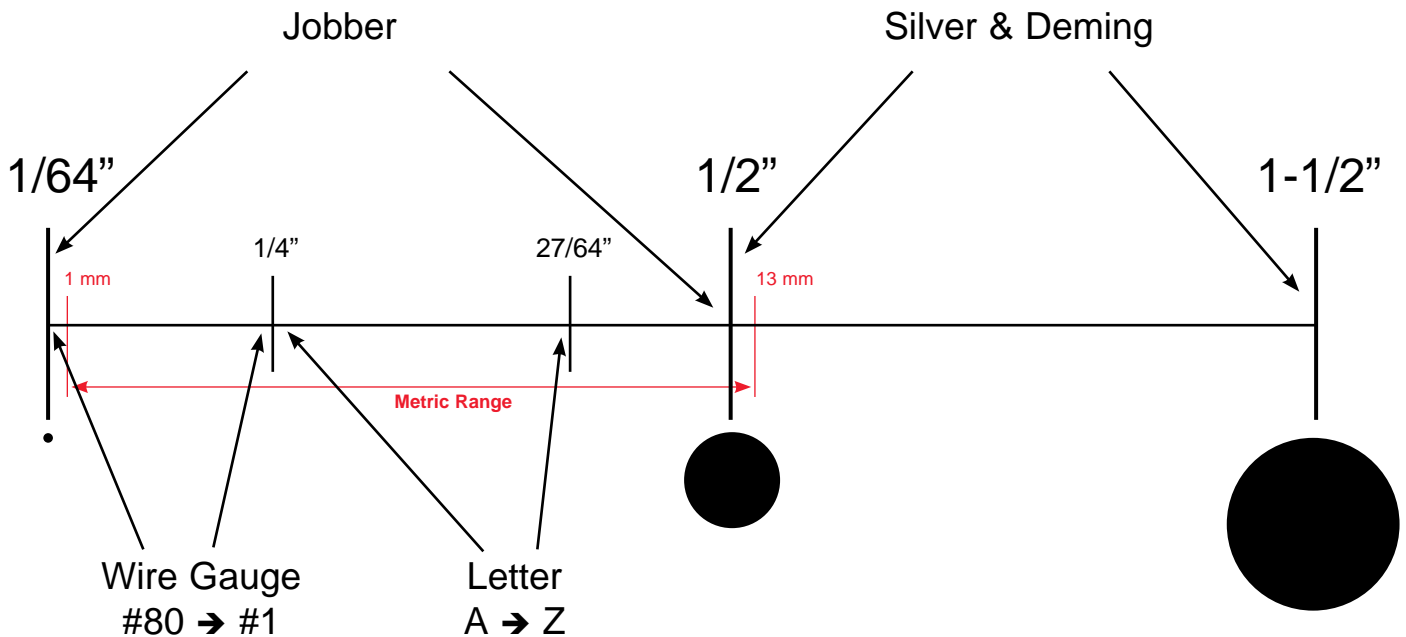

Chart Not To Scale.



INTERNATIONAL TOOL MANUFACTURING

150 Express St. Plainview, NY 11803

(516) 738-0388 • (800) 247-5696

ITM® Fax (516) 279-1106

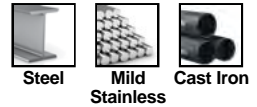

Black Oxide Jobber Drills - HEAVY DUTY - *M2 HSS*

Pg. 13+



Black & Gold Jobber Drills - HEAVY DUTY - *M2 HSS*

Pg. 17+



Mechanics Drill Bits are Slightly Shorter Than a Standard Jobber Drill.

Black & Gold Mechanics Drills - HEAVY DUTY - *M2 HSS*

Pg. 18



1/4" Hex Black & Gold Jobber Drills - *M2 HSS*

Pg. 19



Cobalt Jobber Drills - HEAVY DUTY - M35 COBALT

Pg. 22+



Titanium Jobber Drills - (TiN) Coating - *M2 HSS*

Pg. 24



1/4" Hex Titanium Jobber Drills - (TiN) Coating - *M2 HSS*

Pg. 24



Black & Gold VIP-STEP Jobber Drills - *M2 HSS*

Pg. 26



118° POINT



- ◆ Jobber Length
- ◆ 118° Point
- ◆ General Purpose
- ◆ Roll Forged
- ◆ Straight Shank
- ◆ Two Tone Finish
- ◆ M2 HSS



1/2" DRILL

Jobber Drills - General Purpose - TWO TONE FINISH - M2 HSS

Part #	Size	Dec.	OAL	Flute	Qty.	List	Part #	Size	Dec.	OAL	Flute	Qty.
200HS0864	1/8"	.1250	2-3/4"	1-5/8"	12	\$1.30	200HS2064	5/16"	.3125	4-1/2"	3-3/16"	12
200HS1064	5/32"	.1562	3-1/8"	2"	12	\$1.50	200HS2464	3/8"	.3750	5"	3-5/8"	6
200HS1264	3/16"	.1875	3-1/2"	2-5/16"	12	\$1.82	200HS2864	7/16"	.4375	5-1/2"	4-1/16"	6
200HS1464	7/32"	.2188	3-3/4"	2-1/2"	12	\$2.36	200HS3264	1/2"	.5000	6"	4-1/2"	6
200HS1664	1/4"	.2500	4"	2-3/4"	12	\$3.05						



Ground Flute



118° POINT



- ◆ Jobber Length
- ◆ 118° Point
- ◆ General Purpose
- ◆ Ground Flute
- ◆ Straight Shank
- ◆ Bright Finish
- ◆ M2 HSS



1/2" DRILL

Jobber Drills - General Purpose - BRIGHT FINISH - M2 HSS

Part #	Size	Dec.	OAL	Flute	Qty.	List	Part #	Size	Dec.	OAL	Flute	Qty.
250US0864	1/8"	.1250	2-3/4"	1-5/8"	12	\$1.55	250US2064	5/16"	.3125	4-1/2"	3-3/16"	12
250US1064	5/32"	.1562	3-1/8"	2"	12	\$1.98	250US2464	3/8"	.3750	5"	3-5/8"	6
250US1264	3/16"	.1875	3-1/2"	2-5/16"	12	\$3.10	250US2864	7/16"	.4375	5-1/2"	4-1/16"	6
250US1464	7/32"	.2188	3-3/4"	2-1/2"	12	\$3.53	250US3264	1/2"	.5000	6"	4-1/2"	6
250US1664	1/4"	.2500	4"	2-3/4"	12	\$5.25						



118° POINT



- ◆ Jobber Length
- ◆ 118° Point
- ◆ General Purpose
- ◆ Roll Forged
- ◆ Straight Shank
- ◆ Black Oxide Finish
- ◆ M2 HSS



1/2" DRILL

Jobber Drills - General Purpose - BLACK FINISH - M2 HSS

Part #	Size	Dec.	OAL	Flute	Qty.	List	Part #	Size	Dec.	OAL	Flute	Qty.
200BF0864	1/8"	.1250	2-3/4"	1-5/8"	12	\$1.06	200BF2064	5/16"	.3125	4-1/2"	3-3/16"	12
200BF1064	5/32"	.1562	3-1/8"	2"	12	\$1.11	200BF2464	3/8"	.3750	5"	3-5/8"	6
200BF1264	3/16"	.1875	3-1/2"	2-5/16"	12	\$1.30	200BF2864	7/16"	.4375	5-1/2"	4-1/16"	6
200BF1464	7/32"	.2188	3-3/4"	2-1/2"	12	\$1.65	200BF3264	1/2"	.5000	6"	4-1/2"	6
200BF1664	1/4"	.2500	4"	2-3/4"	12	\$2.16						



ALL JOBBER SIZES 1/16" → 1/2" AVAILABLE IN 135° SPLIT POINT - SEE PG.12

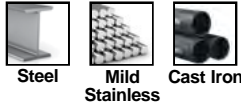

Black Oxide Jobber Drills - HEAVY DUTY - M2 HSS

- ◆ Jobber Length
- ◆ 135° Split Point
- ◆ Ground Flute
- ◆ Straight Shank
- ◆ Heavy Duty Web
- ◆ Black Oxide Finish
- ◆ M2 HSS



Part #	Size	Dec.	OAL	Flute	Qty.	Part #	Size	Dec.	OAL	Flute	Qty.
206SP0464	1/16"	.0625	1-7/8"	7/8"	12	206SP1964	19/64"	.2969	4-3/8"	3-1/16"	12
206SP0564	5/64"	.0781	2"	1"	12	206SP2064	5/16"	.3125	4-1/2"	3-3/16"	12
206SP0664	3/32"	.0938	2-1/4"	1-1/4"	12	206SP2164	21/64"	.3281	4-5/8"	3-5/16"	6
206SP0764	7/64"	.1094	2-5/8"	1-1/2"	12	206SP2264	11/32"	.3438	4-3/4"	3-7/16"	6
206SP0864	1/8"	.1250	2-3/4"	1-5/8"	12	206SP2364	23/64"	.3594	4-7/8"	3-1/2"	6
206SP0964	9/64"	.1406	2-7/8"	1-3/4"	12	206SP2464	3/8"	.3750	5"	3-5/8"	6
206SP1064	5/32"	.1562	3-1/8"	2"	12	206SP2564	25/64"	.3906	5-1/8"	3-3/4"	6
206SP1164	11/64"	.1719	3-1/4"	2-1/8"	12	206SP2664	13/32"	.4062	5-1/4"	3-7/8"	6
206SP1264	3/16"	.1875	3-1/2"	2-5/16"	12	206SP2764	27/64"	.4219	5-3/8"	3-15/16"	6
206SP1364	13/64"	.2031	3-5/8"	2-7/16"	12	206SP2864	7/16"	.4375	5-1/2"	4-1/16"	6
206SP1464	7/32"	.2188	3-3/4"	2-1/2"	12	206SP2964	29/64"	.4531	5-5/8"	4-3/16"	6
206SP1564	15/64"	.2344	3-7/8"	2-5/8"	12	206SP3064	15/32"	.4688	5-3/4"	4-5/16"	6
206SP1664	1/4"	.2500	4"	2-3/4"	12	206SP3164	31/64"	.4844	5-7/8"	4-3/8"	6
206SP1764	17/64"	.2656	4-1/8"	2-7/8"	12	206SP3264	1/2"	.5000	6"	4-1/2"	6
206SP1864	9/32"	.2812	4-1/4"	2-15/16"	12						

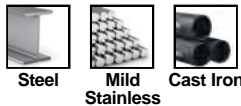

Black Oxide Wire Gauge Drills - HEAVY DUTY - M2 HSS

- ◆ Wire Gauge
- ◆ 135° Split Point
- ◆ Ground Flute
- ◆ Straight Shank
- ◆ Heavy Duty Web
- ◆ Black Oxide Finish
- ◆ M2 HSS



Part #	Size	Dec.	OAL	Flute	Qty.	Part #	Size	Dec.	OAL	Flute	Qty.
207SP0001	1	.2280	3-7/8"	2-5/8"	12	207SP0031	31	.1200	2-3/4"	1-5/8"	12
207SP0002	2	.2210	3-7/8"	2-5/8"	12	207SP0032	32	.1160	2-3/4"	1-5/8"	12
207SP0003	3	.2130	3-3/4"	2-1/2"	12	207SP0033	33	.1130	2-5/8"	1-1/2"	12
207SP0004	4	.2090	3-3/4"	2-1/2"	12	207SP0034	34	.1110	2-5/8"	1-1/2"	12
207SP0005	5	.2055	3-3/4"	2-1/2"	12	207SP0035	35	.1100	2-5/8"	1-1/2"	12
207SP0006	6	.2040	3-3/4"	2-1/2"	12	207SP0036	36	.1065	2-1/2"	1-7/16"	12
207SP0007	7	.2010	3-5/8"	2-7/16"	12	207SP0037	37	.1040	2-1/2"	1-7/16"	12
207SP0008	8	.1990	3-5/8"	2-7/16"	12	207SP0038	38	.1015	2-1/2"	1-7/16"	12
207SP0009	9	.1960	3-5/8"	2-7/16"	12	207SP0039	39	.0995	2-3/8"	1-3/8"	12
207SP0010	10	.1935	3-5/8"	2-7/16"	12	207SP0040	40	.0980	2-3/8"	1-3/8"	12
207SP0011	11	.1910	3-1/2"	2-5/16"	12	207SP0041	41	.0960	2-3/8"	1-3/8"	12
207SP0012	12	.1890	3-1/2"	2-5/16"	12	207SP0042	42	.0935	2-1/4"	1-1/4"	12
207SP0013	13	.1850	3-1/2"	2-5/16"	12	207SP0043	43	.0890	2-1/4"	1-1/4"	12
207SP0014	14	.1820	3-3/8"	2-3/16"	12	207SP0044	44	.0860	2-1/8"	1-1/8"	12
207SP0015	15	.1800	3-3/8"	2-3/16"	12	207SP0045	45	.0820	2-1/8"	1-1/8"	12
207SP0016	16	.1770	3-3/8"	2-3/16"	12	207SP0046	46	.0810	2-1/8"	1-1/8"	12
207SP0017	17	.1730	3-3/8"	2-3/16"	12	207SP0047	47	.0785	2"	1"	12
207SP0018	18	.1695	3-1/4"	2-1/8"	12	207SP0048	48	.0760	2"	1"	12
207SP0019	19	.1660	3-1/4"	2-1/8"	12	207SP0049	49	.0730	2"	1"	12
207SP0020	20	.1610	3-1/4"	2-1/8"	12	207SP0050	50	.0700	2"	1"	12
207SP0021	21	.1590	3-1/4"	2-1/8"	12	207SP0051	51	.0670	2"	1"	12
207SP0022	22	.1570	3-1/8"	2"	12	207SP0052	52	.0635	1-7/8"	7/8"	12
207SP0023	23	.1540	3-1/8"	2"	12	207SP0053	53	.0595	1-7/8"	7/8"	12
207SP0024	24	.1520	3-1/8"	2"	12	207SP0054	54	.0550	1-7/8"	7/8"	12
207SP0025	25	.1495	3"	1-7/8"	12	207SP0055	55	.0520	1-7/8"	7/8"	12
207SP0026	26	.1470	3"	1-7/8"	12	207SP0056	56	.0465	1-3/4"	3/4"	12
207SP0027	27	.1440	3"	1-7/8"	12	207SP0057	57	.0430	1-3/4"	3/4"	12
207SP0028	28	.1405	2-7/8"	1-3/4"	12	207SP0058	58	.0420	1-5/8"	11/16"	12
207SP0029	29	.1360	2-7/8"	1-3/4"	12	207SP0059	59	.0410	1-5/8"	11/16"	12
207SP0030	30	.1285	2-3/4"	1-5/8"	12	207SP0060	60	.0400	1-5/8"	11/16"	12

i
NOTE:
SIZES 40 → 60
HAVE NO
SPLIT POINT.



Jobber Drills - HEAVY DUTY 3/8" Shank - BLACK OXIDE FINISH - M2 HSS

Part #	Size	Dec.	OAL	Flute	Qty.	Part #	Size	Dec.	OAL	Flute	Qty.
206R82564	25/64"	.3906	5-1/8"	3-3/4"	6	206R82964	29/64"	.4531	5-3/8"	4-3/16"	6
206R82664	13/32"	.4062	5-1/4"	3-1/8"	6	206R83064	15/32"	.4688	5-3/4"	4-5/16"	6
206R82764	27/64"	.4219	5-3/8"	3-15/16"	6	206R83164	31/64"	.4844	5-7/8"	4-3/8"	6
206R82864	7/16"	.4375	5-1/2"	4-1/16"	6	206R83264	1/2"	.5000	6"	4-1/2"	6

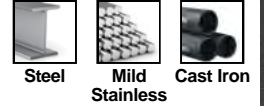

◆ Same as 206SP with 3/8" Shank.



Black Oxide Letter Drills - HEAVY DUTY - M2 HSS

Part #	Size	Dec.	OAL	Flute	Qty.	Part #	Size	Dec.	OAL	Flute	Qty.
208SP000A	A	.2340	3-7/8"	2-5/8"	12	208SP000N	N	.3020	4-3/8"	3-1/16"	6
208SP000B	B	.2380	4"	2-3/4"	12	208SP000O	O	.3160	4-1/2"	3-3/16"	6
208SP000C	C	.2420	4"	2-3/4"	12	208SP000P	P	.3230	4-5/8"	3-5/16"	6
208SP000D	D	.2460	4"	2-3/4"	12	208SP000Q	Q	.3320	4-3/4"	3-7/16"	6
208SP000E	E	.2500	4"	2-3/4"	12	208SP000R	R	.3390	4-3/4"	3-7/16"	6
208SP000F	F	.2570	4-1/8"	2-7/8"	12	208SP000S	S	.3480	4-7/8"	3-1/2"	6
208SP000G	G	.2610	4-1/8"	2-7/8"	12	208SP000T	T	.3580	4-7/8"	3-1/2"	6
208SP000H	H	.2660	4-1/8"	2-7/8"	12	208SP000U	U	.3680	5"	3-5/8"	6
208SP000I	I	.2720	4-1/8"	2-7/8"	12	208SP000V	V	.3770	5"	3-5/8"	6
208SP000J	J	.2770	4-1/8"	2-7/8"	12	208SP000W	W	.3860	5-1/8"	3-3/4"	6
208SP000K	K	.2810	4-1/4"	2-15/16"	12	208SP000X	X	.3970	5-1/8"	3-3/4"	6
208SP000L	L	.2900	4-1/4"	2-15/16"	6	208SP000Y	Y	.4040	5-1/4"	3-7/8"	6
208SP000M	M	.2950	4-3/8"	3-1/16"	6	208SP000Z	Z	.4130	5-1/4"	3-7/8"	6

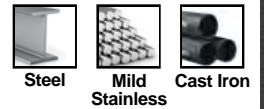

- ◆ Jobber Length
- ◆ 135° Split Point
- ◆ Ground Flute
- ◆ Straight Shank
- ◆ Heavy Duty Web
- ◆ Black Oxide Finish
- ◆ M2 HSS



Metric Drills - General Purpose - BLACK OXIDE FINISH - M2 HSS

Part #	Size	Dec.	OAL	Flute	Qty.	Part #	Size	Dec.	OAL	Flute	Qty.
205HS0010	1	.0393	41	18	12	205HS0075	7.5	.2953	111	78	12
205HS0015	1.5	.0591	48	22	12	205HS0080	8	.3150	114	81	12
205HS0020	2	.0787	54	29	12	205HS0085	8.5	.3346	121	87	6
205HS0025	2.5	.0984	60	35	12	205HS0090	9	.3543	124	89	6
205HS0030	3	.1181	70	41	12	205HS0095	9.5	.3740	127	92	6
205HS0035	3.5	.1378	73	45	12	205HS0100	10	.3937	130	95	6
205HS0040	4	.1575	83	54	12	205HS0105	10.5	.4134	137	100	6
205HS0045	4.5	.1772	86	56	12	205HS0110	11	.4331	140	103	6
205HS0050	5	.1969	92	62	12	205HS0115	11.5	.4528	143	106	6
205HS0055	5.5	.2165	95	64	12	205HS0120	12	.4724	150	111	6
205HS0060	6	.2362	102	70	12	205HS0125	12.5	.4921	152	114	6
205HS0065	6.5	.2559	105	73	12	205HS0130	13	.5118	168	122	6
205HS0070	7	.2756	105	73	12						

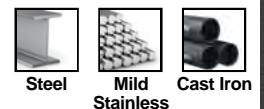

- ◆ Metric Size
- ◆ 118° Point
- ◆ General Purpose
- ◆ Roll Forged
- ◆ Straight Shank
- ◆ Black Oxide Finish
- ◆ M2 HSS





Steel

Cast Iron

Sheet Metal

Mild Stainless

- ◆ Stub Length
- ◆ 135° Split Point
- ◆ Ground Flute
- ◆ Straight Shank
- ◆ Heavy Duty Web
- ◆ Black Oxide Finish
- ◆ M2 HSS



STUB Fractional - M2 HSS

Part #	Size	Dec.	OAL	Flute	Qty.
209SM0464	1/16"	.0625	1-5/8"	5/8"	12
209SM0564	5/64"	.0781	1-11/16"	11/16"	12
209SM0664	3/32"	.0938	1-3/4"	3/4"	12
209SM0764	7/64"	.1094	1-13/16"	13/16"	12
209SM0864	1/8"	.1250	1-7/8"	7/8"	12
209SM0964	9/64"	.1406	1-15/16"	15/16"	12
209SM1064	5/32"	.1562	2-1/16"	1"	12
209SM1164	11/64"	.1719	2-1/8"	1-1/16"	12
209SM1264	3/16"	.1875	2-3/16"	1-1/8"	12
209SM1364	13/64"	.2031	2-1/4"	1-3/16"	12
209SM1464	7/32"	.2188	2-3/8"	1-1/4"	12
209SM1564	15/64"	.2344	2-7/16"	1-5/16"	12
209SM1664	1/4"	.2500	2-1/2"	1-3/8"	12
209SM1764	17/64"	.2656	2-5/8"	1-7/16"	12
209SM1864	9/32"	.2812	2-11/16"	1-1/2"	12
209SM1964	19/64"	.2969	2-3/4"	1-9/16"	12
209SM2064	5/16"	.3125	2-13/16"	1-5/8"	12
209SM2164	21/64"	.3281	2-15/16"	1-11/16"	6
209SM2264	11/32"	.3438	3"	1-11/16"	6
209SM2364	23/64"	.3594	3-1/16"	1-3/4"	6
209SM2464	3/8"	.3750	3-1/8"	1-13/16"	6
209SM2564	25/64"	.3906	3-1/4"	1-7/8"	6
209SM2664	13/32"	.4062	3-5/16"	1-15/16"	6
209SM2764	27/64"	.4219	3-3/8"	2"	6
209SM2864	7/16"	.4375	3-7/16"	2-1/16"	6
209SM2964	29/64"	.4531	3-9/16"	2-1/8"	6
209SM3064	15/32"	.4688	3-5/8"	2-1/8"	6
209SM3164	31/64"	.4844	3-11/16"	2-3/16"	6
209SM3264	1/2"	.5000	3-3/4"	2-1/4"	6



STUB Wire Gauge - M2 HSS

Part #	Size	Dec.	OAL	Flute	Qty.
210SM0001	1	.2280	2-7/16"	1-15/16"	12
210SM0002	2	.2210	2-7/16"	1-15/16"	12
210SM0003	3	.2130	2-3/8"	1-1/4"	12
210SM0004	4	.2090	2-3/8"	1-1/4"	12
210SM0005	5	.2055	2-3/8"	1-1/4"	12
210SM0006	6	.2040	2-3/8"	1-1/4"	12
210SM0007	7	.2010	2-1/4"	1-3/16"	12
210SM0008	8	.1990	2-1/4"	1-3/16"	12
210SM0009	9	.1960	2-1/4"	1-3/16"	12
210SM0010	10	.1935	2-1/4"	1-3/16"	12
210SM0011	11	.1910	2-1/4"	1-3/16"	12
210SM0012	12	.1890	2-1/4"	1-3/16"	12
210SM0013	13	.1850	2-3/16"	1-1/8"	12
210SM0014	14	.1820	2-3/16"	1-1/8"	12
210SM0015	15	.1800	2-3/16"	1-1/8"	12
210SM0016	16	.1770	2-3/16"	1-1/8"	12
210SM0017	17	.1730	2-3/16"	1-1/8"	12
210SM0018	18	.1695	2-1/8"	1-1/16"	12
210SM0019	19	.1660	2-1/8"	1-1/16"	12
210SM0020	20	.1610	2-1/8"	1-1/16"	12
210SM0021	21	.1590	2-1/8"	1-1/16"	12
210SM0022	22	.1570	2-1/8"	1-1/16"	12
210SM0023	23	.1540	2-1/16"	1"	12
210SM0024	24	.1520	2-1/16"	1"	12
210SM0025	25	.1495	2-1/16"	1"	12
210SM0026	26	.1470	2-1/16"	1"	12
210SM0027	27	.1440	2-1/16"	1"	12
210SM0028	28	.1405	1-15/16"	15/16"	12
210SM0029	29	.1360	1-15/16"	15/16"	12
210SM0030	30	.1285	1-15/16"	15/16"	12
210SM0031	31	.1200	1-7/8"	7/8"	12
210SM0032	32	.1160	1-7/8"	7/8"	12
210SM0033	33	.1130	1-7/8"	7/8"	12
210SM0034	34	.1110	1-7/8"	7/8"	12
210SM0035	35	.1100	1-7/8"	7/8"	12
210SM0036	36	.1065	1-13/16"	13/16"	12
210SM0037	37	.1040	1-13/16"	13/16"	12
210SM0038	38	.1015	1-13/16"	13/16"	12
210SM0039	39	.0995	1-13/16"	13/16"	12
210SM0040	40	.0980	1-13/16"	13/16"	12



BLACK Oxide

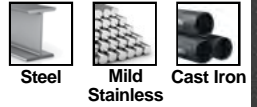

- ◆ 6" Length
- ◆ 118° Point
- ◆ Ground Flute
- ◆ 1/2" Shank
- ◆ Black Oxide Finish
- ◆ M2 HSS



Black Oxide Silver & Deming - 1/2" Shank - M2 HSS

Part #	Size	Dec.	OAL	Flute	Qty.	Part #	Size	Dec.	OAL	Flute	Qty.
201SD3364	33/64"	.5156	6"	2-3/4"	1	201SD5364	53/64"	.8281	6"	2-3/4"	1
201SD3464	17/32"	.5312	6"	2-3/4"	1	201SD5464	27/32"	.8438	6"	2-3/4"	1
201SD3564	35/64"	.5469	6"	2-3/4"	1	201SD5564	55/64"	.8594	6"	2-3/4"	1
201SD3664	9/16"	.5625	6"	2-3/4"	1	201SD5664	7/8"	.8750	6"	2-3/4"	1
201SD3764	37/64"	.5781	6"	2-3/4"	1	201SD5764	57/64"	.8906	6"	2-3/4"	1
201SD3864	19/32"	.5938	6"	2-3/4"	1	201SD5864	29/32"	.9062	6"	2-3/4"	1
201SD3964	39/64"	.6094	6"	2-3/4"	1	201SD5964	59/64"	.9219	6"	2-3/4"	1
201SD4064	5/8"	.6250	6"	2-3/4"	1	201SD6064	15/16"	.9375	6"	2-3/4"	1
201SD4164	41/64"	.6406	6"	2-3/4"	1	201SD6164	61/64"	.9531	6"	2-3/4"	1
201SD4264	21/32"	.6562	6"	2-3/4"	1	201SD6264	31/32"	.9688	6"	2-3/4"	1
201SD4364	43/64"	.6719	6"	2-3/4"	1	201SD6364	63/64"	.9844	6"	2-3/4"	1
201SD4464	11/16"	.6875	6"	2-3/4"	1	201SD6464	1"	1.0000	6"	2-3/4"	1
201SD4564	45/64"	.7031	6"	2-3/4"	1	201SD6864	1-1/16"	1.0625	6"	2-3/4"	1
201SD4664	23/32"	.7188	6"	2-3/4"	1	201SD7264	1-1/8"	1.1250	6"	2-3/4"	1
201SD4764	47/64"	.7344	6"	2-3/4"	1	201SD7664	1-3/16"	1.1875	6"	2-3/4"	1
201SD4864	3/4"	.7500	6"	2-3/4"	1	201SD8064	1-1/4"	1.2500	6"	2-3/4"	1
201SD4964	49/64"	.7656	6"	2-3/4"	1	201SD8464	1-5/16"	1.3125	6"	2-3/4"	1
201SD5064	25/32"	.7812	6"	2-3/4"	1	201SD8864	1-3/8"	1.3750	6"	2-3/4"	1
201SD5164	51/64"	.7969	6"	2-3/4"	1	201SD9664	1-1/2"	1.5000	6"	2-3/4"	1
201SD5264	13/16"	.8125	6"	2-3/4"	1						



BLACK Oxide

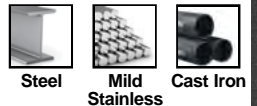

- ◆ 6" Length
- ◆ 118° Point
- ◆ Ground Flute
- ◆ 3/8" Shank
- ◆ Black Oxide Finish
- ◆ M2 HSS



Black Oxide Silver & Deming - 3/8" Shank - M2 HSS

Part #	Size	Dec.	OAL	Flute	Qty.	Part #	Size	Dec.	OAL	Flute	Qty.
201R83364	33/64"	.5156	6"	2-3/4"	1	201R84164	41/64"	.6406	6"	2-3/4"	1
201R83464	17/32"	.5312	6"	2-3/4"	1	201R84264	21/32"	.6562	6"	2-3/4"	1
201R83564	35/64"	.5469	6"	2-3/4"	1	201R84364	43/64"	.6719	6"	2-3/4"	1
201R83664	9/16"	.5625	6"	2-3/4"	1	201R84464	11/16"	.6875	6"	2-3/4"	1
201R83764	37/64"	.5781	6"	2-3/4"	1	201R84564	45/64"	.7031	6"	2-3/4"	1
201R83864	19/32"	.5938	6"	2-3/4"	1	201R84664	23/32"	.7188	6"	2-3/4"	1
201R83964	39/64"	.6094	6"	2-3/4"	1	201R84764	47/64"	.7344	6"	2-3/4"	1
201R84064	5/8"	.6250	6"	2-3/4"	1	201R84864	3/4"	.7500	6"	2-3/4"	1



INTERNATIONAL TOOL MANUFACTURING

150 Express St. Plainview, NY 11803

(516) 738-0388 • (800) 247-5696

ITM Fax (516) 279-1106

100% LAB TESTED

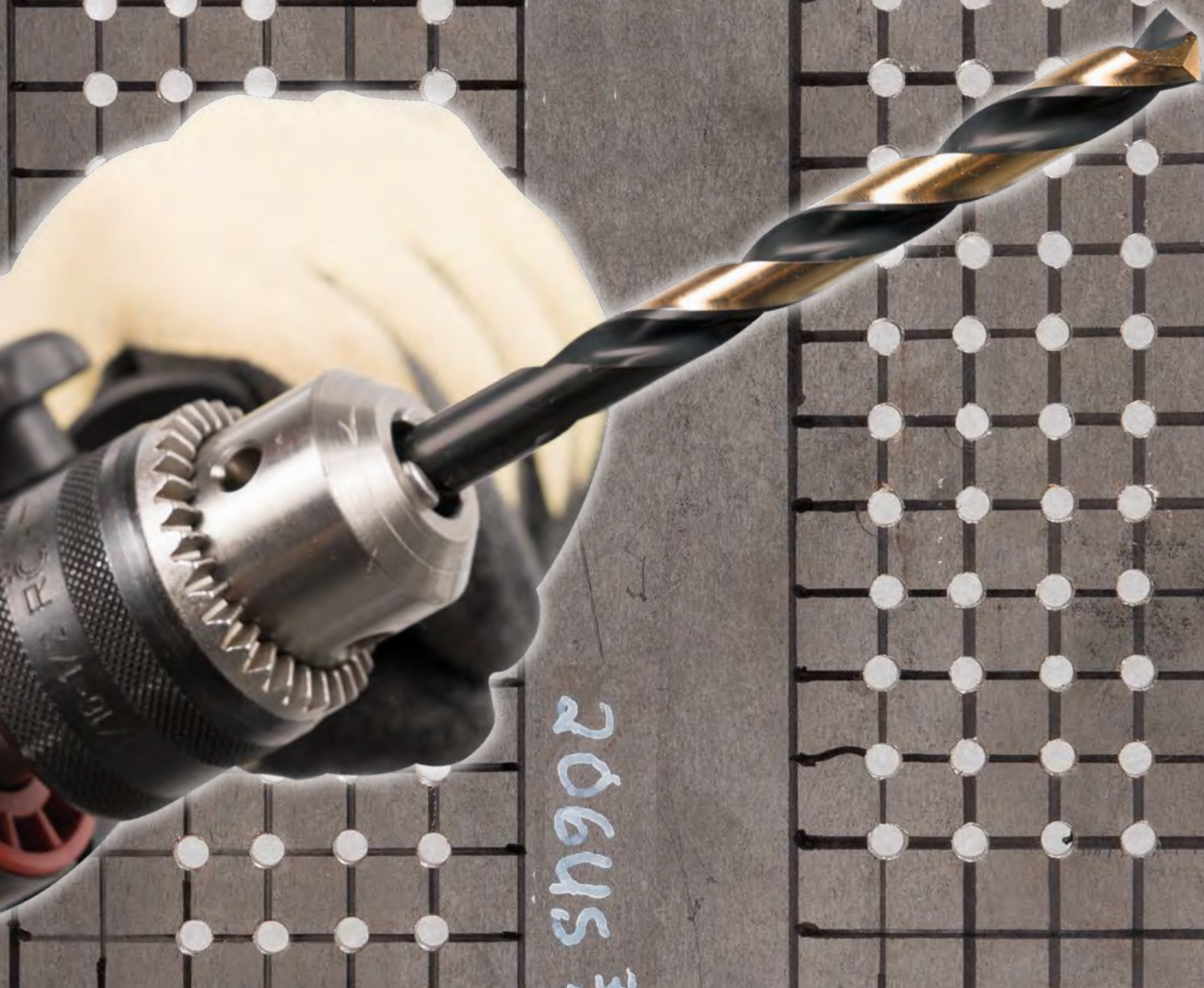

BLACK-GOLD

The Most Recognizable Finish Anywhere.



BLACK-GOLD



- ◆ Jobber Length
- ◆ 135° Split Point
- ◆ Ground Flute
- ◆ Straight Shank
- ◆ Heavy Duty Web
- ◆ Black & Gold Finish
- ◆ M2 HSS



Black & Gold Jobber Drills - HEAVY DUTY - M2 HSS

Part #	Size	Dec.	OAL	Flute	Qty.	Part #	Size	Dec.	OAL	Flute	Qty.
206US0464	1/16"	.0625	1-7/8"	7/8"	12	206US1964	19/64"	.2969	4-3/8"	3-1/16"	12
206US0564	5/64"	.0781	2"	1"	12	206US2064	5/16"	.3125	4-1/2"	3-3/16"	12
206US0664	3/32"	.0938	2-1/4"	1-1/4"	12	206US2164	21/64"	.3281	4-5/8"	3-5/16"	6
206US0764	7/64"	.1094	2-5/8"	1-1/2"	12	206US2264	11/32"	.3438	4-3/4"	3-7/16"	6
206US0864	1/8"	.1250	2-3/4"	1-5/8"	12	206US2364	23/64"	.3594	4-7/8"	3-1/2"	6
206US0964	9/64"	.1406	2-7/8"	1-3/4"	12	206US2464	3/8"	.3750	5"	3-5/8"	6
206US1064	5/32"	.1562	3-1/8"	2"	12	206US2564	25/64"	.3906	5-1/8"	3-3/4"	6
206US1164	11/64"	.1719	3-1/4"	2-1/8"	12	206US2664	13/32"	.4062	5-1/4"	3-7/8"	6
206US1264	3/16"	.1875	3-1/2"	2-5/16"	12	206US2764	27/64"	.4219	5-3/8"	3-15/16"	6
206US1364	13/64"	.2031	3-5/8"	2-7/16"	12	206US2864	7/16"	.4375	5-1/2"	4-1/16"	6
206US1464	7/32"	.2188	3-3/4"	2-1/2"	12	206US2964	29/64"	.4531	5-5/8"	4-3/16"	6
206US1564	15/64"	.2344	3-7/8"	2-5/8"	12	206US3064	15/32"	.4688	5-3/4"	4-5/16"	6
206US1664	1/4"	.2500	4"	2-3/4"	12	206US3164	31/64"	.4844	5-7/8"	4-3/8"	6
206US1764	17/64"	.2656	4-1/8"	2-7/8"	12	206US3264	1/2"	.5000	6"	4-1/2"	6
206US1864	9/32"	.2812	4-1/4"	2-15/16"	12						



Black & Gold Wire Gauge Drills - HEAVY DUTY - M2 HSS

Part #	Size	Dec.	OAL	Flute	Qty.	Part #	Size	Dec.	OAL	Flute	Qty.
207US-01	1	.2280	3-7/8"	2-5/8"	12	207US-31	31	.1200	2-3/4"	1-5/8"	12
207US-02	2	.2210	3-7/8"	2-5/8"	12	207US-32	32	.1160	2-3/4"	1-5/8"	12
207US-03	3	.2130	3-3/4"	2-1/2"	12	207US-33	33	.1130	2-5/8"	1-1/2"	12
207US-04	4	.2090	3-3/4"	2-1/2"	12	207US-34	34	.1110	2-5/8"	1-1/2"	12
207US-05	5	.2055	3-3/4"	2-1/2"	12	207US-35	35	.1100	2-5/8"	1-1/2"	12
207US-06	6	.2040	3-3/4"	2-1/2"	12	207US-36	36	.1065	2-1/2"	1-7/16"	12
207US-07	7	.2010	3-5/8"	2-7/16"	12	207US-37	37	.1040	2-1/2"	1-7/16"	12
207US-08	8	.1990	3-5/8"	2-7/16"	12	207US-38	38	.1015	2-1/2"	1-7/16"	12
207US-09	9	.1960	3-5/8"	2-7/16"	12	207US-39	39	.0995	2-3/8"	1-3/8"	12
207US-10	10	.1935	3-5/8"	2-7/16"	12	207US-40	40	.0980	2-3/8"	1-3/8"	12
207US-11	11	.1910	3-1/2"	2-5/16"	12	207US-41	41	.0960	2-3/8"	1-3/8"	12
207US-12	12	.1890	3-1/2"	2-5/16"	12	207US-42	42	.0935	2-1/4"	1-1/4"	12
207US-13	13	.1850	3-1/2"	2-5/16"	12	207US-43	43	.0890	2-1/4"	1-1/4"	12
207US-14	14	.1820	3-3/8"	2-3/16"	12	207US-44	44	.0860	2-1/8"	1-1/8"	12
207US-15	15	.1800	3-3/8"	2-3/16"	12	207US-45	45	.0820	2-1/8"	1-1/8"	12
207US-16	16	.1770	3-3/8"	2-3/16"	12	207US-46	46	.0810	2-1/8"	1-1/8"	12
207US-17	17	.1730	3-3/8"	2-3/16"	12	207US-47	47	.0785	2"	1"	12
207US-18	18	.1695	3-1/4"	2-1/8"	12	207US-48	48	.0760	2"	1"	12
207US-19	19	.1660	3-1/4"	2-1/8"	12	207US-49	49	.0730	2"	1"	12
207US-20	20	.1610	3-1/4"	2-1/8"	12	207US-50	50	.0700	2"	1"	12
207US-21	21	.1590	3-1/4"	2-1/8"	12	207US-51	51	.0670	2"	1"	12
207US-22	22	.1570	3-1/8"	2"	12	207US-52	52	.0635	1-7/8"	7/8"	12
207US-23	23	.1540	3-1/8"	2"	12	207US-53	53	.0595	1-7/8"	7/8"	12
207US-24	24	.1520	3-1/8"	2"	12	207US-54	54	.0550	1-7/8"	7/8"	12
207US-25	25	.1495	3"	1-7/8"	12	207US-55	55	.0520	1-7/8"	7/8"	12
207US-26	26	.1470	3"	1-7/8"	12	207US-56	56	.0465	1-3/4"	3/4"	12
207US-27	27	.1440	3"	1-7/8"	12	207US-57	57	.0430	1-3/4"	3/4"	12
207US-28	28	.1405	2-7/8"	1-3/4"	12	207US-58	58	.0420	1-5/8"	11/16"	12
207US-29	29	.1360	2-7/8"	1-3/4"	12	207US-59	59	.0410	1-5/8"	11/16"	12
207US-30	30	.1285	2-3/4"	1-5/8"	12	207US-60	60	.0400	1-5/8"	11/16"	12



BLACK-GOLD



- ◆ Wire Gauge
- ◆ 135° Split Point
- ◆ Ground Flute
- ◆ Straight Shank
- ◆ Heavy Duty Web
- ◆ Black & Gold Finish
- ◆ M2 HSS



NOTE:
SIZES 40 → 60
HAVE NO
SPLIT POINT.



INTERNATIONAL TOOL MANUFACTURING

150 Express St. Plainview, NY 11803

(516) 738-0388 • (800) 247-5696

ITM® Fax (516) 279-1106



BLACK-GOLD

Black & Gold Jobber Drills - HEAVY DUTY 3/8" Shank - M2 HSS



Part #	Size	Dec.	OAL	Flute	Qty.	Part #	Size	Dec.	OAL	Flute	Qty.
206U82564	25/64"	.3906	5-1/8"	3-3/4"	6	206U82964	29/64"	.4531	5-5/8"	4-3/16"	6
206U82664	13/32"	.4062	5-1/4"	3-1/8"	6	206U83064	15/32"	.4688	5-3/4"	4-5/16"	6
206U82764	27/64"	.4219	5-3/8"	3-15/16"	6	206U83164	31/64"	.4844	5-7/8"	4-3/8"	6
206U82864	7/16"	.4375	5-1/2"	4-1/16"	6	206U83264	1/2"	.5000	6"	4-1/2"	6

- ◆ Jobber Length
- ◆ 3/8" Shank
- ◆ 135° Split Point
- ◆ Ground Flute
- ◆ Straight Shank
- ◆ Heavy Duty Web
- ◆ M2 HSS



BLACK-GOLD

Black & Gold Mechanics Length Drills - HEAVY DUTY - M2 HSS



Part #	Size	Dec.	OAL	Flute	Qty.	Part #	Size	Dec.	OAL	Flute	Qty.
208MC0464	1/16"	.0625	1 7/8"	7/8"	12	208MC1964	19/64"	.2969	3-7/8"	2-3/8"	12
208MC0564	5/64"	.0781	2"	1"	12	208MC2064	5/16"	.3125	4"	2-1/2"	12
208MC0664	3/32"	.0938	2-1/4"	1-1/4"	12	208MC2164	21/64"	.3281	4-1/16"	2-9/16"	6
208MC0764	7/64"	.1094	2-3/8"	1-5/16"	12	208MC2264	11/32"	.3438	4-1/8"	2-5/8"	6
208MC0864	1/8"	.1250	2-1/2"	1-7/16"	12	208MC2364	23/64"	.3594	4-3/16"	2-11/16"	6
208MC0964	9/64"	.1406	2-5/8"	1-9/16"	12	208MC2464	3/8"	.3750	4-1/4"	2-11/16"	6
208MC1064	5/32"	.1562	2-3/4"	1-11/16"	12	208MC2564	25/64"	.3906	4-5/16"	2-3/4"	6
208MC1164	11/64"	.1719	2-7/8"	1-13/16"	12	208MC2664	13/32"	.4062	4-3/8"	2-13/16"	6
208MC1264	3/16"	.1875	3"	1-7/8"	12	208MC2764	27/64"	.4219	4-7/16"	2-7/8"	6
208MC1364	13/64"	.2031	3-1/8"	1-15/16"	12	208MC2864	7/16"	.4375	4-1/2"	2-15/16"	6
208MC1464	7/32"	.2188	3-1/4"	2"	12	208MC2964	29/64"	.4531	4-5/8"	3"	6
208MC1564	15/64"	.2344	3-3/8"	2"	12	208MC3064	15/32"	.4688	4-3/4"	3-1/8"	6
208MC1664	1/4"	.2500	3-1/2"	2"	12	208MC3164	31/64"	.4844	4-7/8"	3-1/4"	6
208MC1764	17/64"	.2656	3-5/8"	2-1/8"	12	208MC3264	1/2"	.5000	5"	3-3/8"	6
208MC1864	9/32"	.2812	3-3/4"	2-1/4"	12						



- ◆ Mechanics Length
- ◆ 135° Split Point
- ◆ 3-Flat Shank (3/16" → 1/2")
- ◆ Black & Gold Finish
- ◆ Heavy Duty Web for Strength & Rigidity
- ◆ M2 HSS



BLACK-GOLD

Black & Gold Letter Drills - HEAVY DUTY - M2 HSS



Part #	Size	Dec.	OAL	Flute	Qty.	Part #	Size	Dec.	OAL	Flute	Qty.
208US-A	A	.234	3-7/8"	2-5/8"	12	208US-N	N	.302	4-3/8"	3-1/16"	6
208US-B	B	.238	4"	2-3/4"	12	208US-O	O	.316	4-1/2"	3-3/16"	6
208US-C	C	.242	4"	2-3/4"	12	208US-P	P	.323	4-5/8"	3-5/16"	6
208US-D	D	.246	4"	2-3/4"	12	208US-Q	Q	.332	4-3/4"	3-7/16"	6
208US-E	E	.250	4"	2-3/4"	12	208US-R	R	.339	4-3/4"	3-7/16"	6
208US-F	F	.257	4-1/8"	2-7/8"	12	208US-S	S	.348	4-7/8"	3-1/2"	6
208US-G	G	.261	4-1/8"	2-7/8"	12	208US-T	T	.358	4-7/8"	3-1/2"	6
208US-H	H	.266	4-1/8"	2-7/8"	12	208US-U	U	.368	5"	3-5/8"	6
208US-I	I	.272	4-1/8"	2-7/8"	12	208US-V	V	.377	5"	3-5/8"	6
208US-J	J	.277	4-1/8"	2-7/8"	12	208US-W	W	.386	5-1/8"	3-3/4"	6
208US-K	K	.281	4-1/4"	2-15/16"	12	208US-X	X	.397	5-1/8"	3-3/4"	6
208US-L	L	.290	4-1/4"	2-15/16"	6	208US-Y	Y	.404	5-1/4"	3-7/8"	6
208US-M	M	.295	4-3/8"	3-1/16"	6	208US-Z	Z	.413	5-1/4"	3-7/8"	6

- ◆ Jobber Length
- ◆ 135° Split Point
- ◆ Ground Flute
- ◆ Straight Shank
- ◆ Heavy Duty Web
- ◆ Black & Gold Finish
- ◆ M2 HSS



1/4" Hex Black & Gold Jobber Drills - M2 HSS

Part #	Size	Dec.	OAL	Flute	Qty.	Part #	Size	Dec.	OAL	Flute	Qty.
206HEX0464	1/16"	.0625	1-7/8"	7/8"	12	206HEX1664	1/4"	.2500	4"	2-3/4"	12
206HEX0664	3/32"	.0938	2-1/4"	1-1/4"	12	206HEX1864	9/32"	.2812	4-1/4"	2-15/16"	12
206HEX0864	1/8"	.1250	2-3/4"	1-5/8"	12	206HEX2064	5/16"	.3125	4-1/2"	3-3/16"	12
206HEX1064	5/32"	.1562	3-1/8"	2"	12	206HEX2464	3/8"	.3750	5"	3-5/8"	6
206HEX1264	3/16"	.1875	3-1/2"	2-5/16"	12	206HEX2864	7/16"	.4375	5-1/2"	4-1/16"	6
206HEX1464	7/32"	.2188	3-3/4"	2-1/2"	12	206HEX3264	1/2"	.5000	6"	4-1/2"	6



BLACK-GOLD



- ◆ 1/4" Hex Impact Shank
- ◆ 135° Split Point
- ◆ 1 Pc. Construction >3/16"
- ◆ Ground Flute
- ◆ Heavy Duty Web
- ◆ M2 HSS

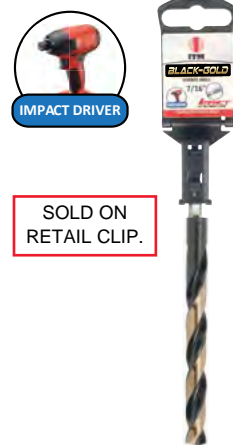

SOLD ON RETAIL CLIP.

1/4" Hex Black & Gold Jobber Drills - M2 HSS

Part #	Size	Dec.	OAL	Flute	Qty.	Part #	Size	Dec.	OAL	Flute	Qty.
206H04	1/16"	.0625	1-7/8"	7/8"	1	206H16	1/4"	.2500	4"	2-3/4"	1
206H06	3/32"	.0938	2-1/4"	1-1/4"	1	206H18	9/32"	.2812	4-1/4"	2-15/16"	1
206H08	1/8"	.1250	2-3/4"	1-5/8"	1	206H20	5/16"	.3125	4-1/2"	3-3/16"	1
206H10	5/32"	.1562	3-1/8"	2"	1	206H24	3/8"	.3750	5"	3-5/8"	1
206H12	3/16"	.1875	3-1/2"	2-5/16"	1	206H28	7/16"	.4375	5-1/2"	4-1/16"	1
206H14	7/32"	.2188	3-3/4"	2-1/2"	1	206H32	1/2"	.5000	6"	4-1/2"	1



Black & Gold Silver & Deming - 1/2" Shank - M2 HSS

Part #	Size	Dec.	OAL	Flute	Qty.	Part #	Size	Dec.	OAL	Flute	Qty.
201US3364	33/64"	.5156	6"	2-3/4"	1	201US5164	51/64"	.7969	6"	2-3/4"	1
201US3464	17/32"	.5312	6"	2-3/4"	1	201US5264	13/16"	.8125	6"	2-3/4"	1
201US3564	35/64"	.5469	6"	2-3/4"	1	201US5364	53/64"	.8281	6"	2-3/4"	1
201US3664	9/16"	.5625	6"	2-3/4"	1	201US5464	27/32"	.8438	6"	2-3/4"	1
201US3764	37/64"	.5781	6"	2-3/4"	1	201US5564	55/64"	.8594	6"	2-3/4"	1
201US3864	19/32"	.5938	6"	2-3/4"	1	201US5664	7/8"	.8750	6"	2-3/4"	1
201US3964	39/64"	.6094	6"	2-3/4"	1	201US5764	57/64"	.8906	6"	2-3/4"	1
201US4064	5/8"	.6250	6"	2-3/4"	1	201US5864	29/32"	.9062	6"	2-3/4"	1
201US4164	41/64"	.6406	6"	2-3/4"	1	201US5964	59/64"	.9219	6"	2-3/4"	1
201US4264	21/32"	.6562	6"	2-3/4"	1	201US6064	15/16"	.9375	6"	2-3/4"	1
201US4364	43/64"	.6719	6"	2-3/4"	1	201US6164	61/64"	.9531	6"	2-3/4"	1
201US4464	11/16"	.6875	6"	2-3/4"	1	201US6264	31/32"	.9688	6"	2-3/4"	1
201US4564	45/64"	.7031	6"	2-3/4"	1	201US6364	63/64"	.9844	6"	2-3/4"	1
201US4664	23/32"	.7188	6"	2-3/4"	1	201US6464	1"	1.0000	6"	2-3/4"	1
201US4764	47/64"	.7344	6"	2-3/4"	1	201US6864	1-1/16"	1.0625	6"	2-3/4"	1
201US4864	3/4"	.7500	6"	2-3/4"	1	201US7264	1-1/8"	1.1250	6"	2-3/4"	1
201US4964	49/64"	.7656	6"	2-3/4"	1	201US7664	1-3/16"	1.1875	6"	2-3/4"	1
201US5064	25/32"	.7812	6"	2-3/4"	1	201US8064	1-1/4"	1.2500	6"	2-3/4"	1

BLACK-GOLD

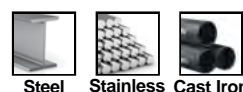

- ◆ 6" Length
- ◆ 118° Split Point
- ◆ Ground Flute
- ◆ 3-Flat Round 1/2" Shank
- ◆ Heavy Duty Web
- ◆ Black & Gold Finish
- ◆ M2 HSS





INTERNATIONAL TOOL MANUFACTURING

150 Express St. Plainview, NY 11803

(516) 738-0388 • (800) 247-5696

ITM® Fax (516) 279-1106

3-Flat, No-Slip Shank

(3/16" → 1/2")

Made in U.S.A.



BLACK-GOLD

MRO Black & Gold Jobber Drills - HEAVY DUTY - M2 HSS



- ◆ Jobber Length
- ◆ 135° Split Point
- ◆ Ground Flute
- ◆ 3-Flat Shank (3/16" → 1/2")
- ◆ 3-Flat Shank On All Letter Drills
- ◆ Heavy Duty Web for Strength & Rigidity
- ◆ Black & Gold Finish
- ◆ M2 HSS

Part #	Size	Dec.	OAL	Flute	Qty.	Part #	Size	Dec.	OAL	Flute	Qty.
MRO-0464	1/16"	.0625	1-7/8"	7/8"	12	MRO-1964	19/64"	.2969	4-3/8"	3-1/16"	12
MRO-0564	5/64"	.0781	2"	1"	12	MRO-2064	5/16"	.3125	4-1/2"	3-3/16"	12
MRO-0664	3/32"	.0938	2-1/4"	1-1/4"	12	MRO-2164	21/64"	.3281	4-5/8"	3-5/16"	6
MRO-0764	7/64"	.1094	2-5/8"	1-1/2"	12	MRO-2264	11/32"	.3438	4-3/4"	3-7/16"	6
MRO-0864	1/8"	.1250	2-3/4"	1-5/8"	12	MRO-2364	23/64"	.3594	4-7/8"	3-1/2"	6
MRO-0964	9/64"	.1406	2-7/8"	1-3/4"	12	MRO-2464	3/8"	.3750	5"	3-5/8"	6
MRO-1064	5/32"	.1562	3-1/8"	2"	12	MRO-2564	25/64"	.3906	5-1/8"	3-3/4"	6
MRO-1164	11/64"	.1719	3-1/4"	2-1/8"	12	MRO-2664	13/32"	.4062	5-1/4"	3-7/8"	6
MRO-1264	3/16"	.1875	3-1/2"	2-5/16"	12	MRO-2764	27/64"	.4219	5-3/8"	3-15/16"	6
MRO-1364	13/64"	.2031	3-5/8"	2-7/16"	12	MRO-2864	7/16"	.4375	5-1/2"	4-1/16"	6
MRO-1464	7/32"	.2188	3-3/4"	2-1/2"	12	MRO-2964	29/64"	.4531	5-5/8"	4-3/16"	6
MRO-1564	15/64"	.2344	3-7/8"	2-5/8"	12	MRO-3064	15/32"	.4688	5-3/4"	4-5/16"	6
MRO-1664	1/4"	.2500	4"	2-3/4"	12	MRO-3164	31/64"	.4844	5-7/8"	4-3/8"	6
MRO-1764	17/64"	.2656	4-1/8"	2-7/8"	12	MRO-3264	1/2"	.5000	6"	4-1/2"	6
MRO-1864	9/32"	.2812	4-1/4"	2-15/16"	12						



Made In



MRO Black & Gold Letter Drills - HEAVY DUTY - M2 HSS

Part #	Size	Dec.	OAL	Flute	Qty.	Part #	Size	Dec.	OAL	Flute	Qty.
MRO-A	A	.234	3-7/8"	2-5/8"	12	MRO-N	N	.302	4-3/8"	3-1/16"	6
MRO-B	B	.238	4"	2-3/4"	12	MRO-O	O	.316	4-1/2"	3-3/16"	6
MRO-C	C	.242	4"	2-3/4"	12	MRO-P	P	.323	4-5/8"	3-5/16"	6
MRO-D	D	.246	4"	2-3/4"	12	MRO-Q	Q	.332	4-3/4"	3-7/16"	6
MRO-E	E	.250	4"	2-3/4"	12	MRO-R	R	.339	4-3/4"	3-7/16"	6
MRO-F	F	.257	4-1/8"	2-7/8"	12	MRO-S	S	.348	4-7/8"	3-1/2"	6
MRO-G	G	.261	4-1/8"	2-7/8"	12	MRO-T	T	.358	4-7/8"	3-1/2"	6
MRO-H	H	.266	4-1/8"	2-7/8"	12	MRO-U	U	.368	5"	3-5/8"	6
MRO-I	I	.272	4-1/8"	2-7/8"	12	MRO-V	V	.377	5"	3-5/8"	6
MRO-J	J	.277	4-1/8"	2-7/8"	12	MRO-W	W	.386	5-1/8"	3-3/4"	6
MRO-K	K	.281	4-1/4"	2-15/16"	12	MRO-X	X	.397	5-1/8"	3-3/4"	6
MRO-L	L	.290	4-1/4"	2-15/16"	6	MRO-Y	Y	.404	5-1/4"	3-7/8"	6
MRO-M	M	.295	4-3/8"	3-1/16"	6	MRO-Z	Z	.413	5-1/4"	3-7/8"	6



MRO Black & Gold Wire Gauge Drills - HEAVY DUTY - M2 HSS

BLACK-GOLD

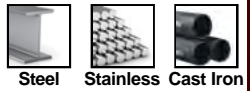

- ◆ 135° Split Point
- ◆ Ground Flute
- ◆ 3-Flat Shank on #1-12
- ◆ Heavy Duty Web for Strength & Rigidity
- ◆ Black & Gold Finish
- ◆ M2 HSS



NOTE:
SIZES 40 → 60
HAVE NO
SPLIT POINT.

Part #	Size	Dec.	OAL	Flute	Qty.	Part #	Size	Dec.	OAL	Flute	Qty.
MRO-01	1	.2280	3-7/8"	2-5/8"	12	MRO-21	21	.1590	3-1/4"	2-1/8"	12
MRO-02	2	.2210	3-7/8"	2-5/8"	12	MRO-22	22	.1570	3-1/8"	2"	12
MRO-03	3	.2130	3-3/4"	2-1/2"	12	MRO-23	23	.1540	3-1/8"	2"	12
MRO-04	4	.2090	3-3/4"	2-1/2"	12	MRO-24	24	.1520	3-1/8"	2"	12
MRO-05	5	.2055	3-3/4"	2-1/2"	12	MRO-25	25	.1495	3"	1-7/8"	12
MRO-06	6	.2040	3-3/4"	2-1/2"	12	MRO-26	26	.1470	3"	1-7/8"	12
MRO-07	7	.2010	3-5/8"	2-7/16"	12	MRO-27	27	.1440	3"	1-7/8"	12
MRO-08	8	.1990	3-5/8"	2-7/16"	12	MRO-28	28	.1405	2-7/8"	1-3/4"	12
MRO-09	9	.1960	3-5/8"	2-7/16"	12	MRO-29	29	.1360	2-7/8"	1-3/4"	12
MRO-10	10	.1935	3-5/8"	2-7/16"	12	MRO-30	30	.1285	2-3/4"	1-5/8"	12
MRO-11	11	.1910	3-1/2"	2-5/16"	12	MRO-31	31	.1200	2-3/4"	1-5/8"	12
MRO-12	12	.1890	3-1/2"	2-5/16"	12	MRO-32	32	.1160	2-3/4"	1-5/8"	12
MRO-13	13	.1850	3-1/2"	2-5/16"	12	MRO-33	33	.1130	2-5/8"	1-1/2"	12
MRO-14	14	.1820	3-3/8"	2-3/16"	12	MRO-34	34	.1110	2-5/8"	1-1/2"	12
MRO-15	15	.1800	3-3/8"	2-3/16"	12	MRO-35	35	.1100	2-5/8"	1-1/2"	12
MRO-16	16	.1770	3-3/8"	2-3/16"	12	MRO-36	36	.1065	2-1/2"	1-7/16"	12
MRO-17	17	.1730	3-3/8"	2-3/16"	12	MRO-37	37	.1040	2-1/2"	1-7/16"	12
MRO-18	18	.1695	3-1/4"	2-1/8"	12	MRO-38	38	.1015	2-1/2"	1-7/16"	12
MRO-19	19	.1660	3-1/4"	2-1/8"	12	MRO-39	39	.0995	2-3/8"	1-3/8"	12
MRO-20	20	.1610	3-1/4"	2-1/8"	12	MRO-40	40	.0980	2-3/8"	1-3/8"	12

**Sizes 41-60 are available upon request.



BLACK-GOLD

MRO
MADE IN USA



COBALT

Cobalt Jobber Drills - HEAVY DUTY - M35 COBALT

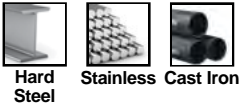

Part #	Size	Dec.	OAL	Flute	Qty.	Part #	Size	Dec.	OAL	Flute	Qty.
219CO0464	1/16"	.0625	1-7/8"	7/8"	12	219CO1964	19/64"	.2969	4-3/8"	3-1/16"	12
219CO0564	5/64"	.0781	2"	1"	12	219CO2064	5/16"	.3125	4-1/2"	3-3/16"	12
219CO0664	3/32"	.0938	2-1/4"	1-1/4"	12	219CO2164	21/64"	.3281	4-5/8"	3-5/16"	6
219CO0764	7/64"	.1094	2-5/8"	1-1/2"	12	219CO2264	11/32"	.3438	4-3/4"	3-7/16"	6
219CO0864	1/8"	.1250	2-3/4"	1-5/8"	12	219CO2364	23/64"	.3594	4-7/8"	3-1/2"	6
219CO0964	9/64"	.1406	2-7/8"	1-3/4"	12	219CO2464	3/8"	.3750	5"	3-5/8"	6
219CO1064	5/32"	.1562	3-1/8"	2"	12	219CO2564	25/64"	.3906	5-1/8"	3-3/4"	6
219CO1164	11/64"	.1719	3-1/4"	2-1/8"	12	219CO2664	13/32"	.4062	5-1/4"	3-7/8"	6
219CO1264	3/16"	.1875	3-1/2"	2-5/16"	12	219CO2764	27/64"	.4219	5-3/8"	3-15/16"	6
219CO1364	13/64"	.2031	3-5/8"	2-7/16"	12	219CO2864	7/16"	.4375	5-1/2"	4-1/16"	6
219CO1464	7/32"	.2188	3-3/4"	2-1/2"	12	219CO2964	29/64"	.4531	5-5/8"	4-3/16"	6
219CO1564	15/64"	.2344	3-7/8"	2-5/8"	12	219CO3064	15/32"	.4688	5-3/4"	4-5/16"	6
219CO1664	1/4"	.2500	4"	2-3/4"	12	219CO3164	31/64"	.4844	5-7/8"	4-3/8"	6
219CO1764	17/64"	.2656	4-1/8"	2-7/8"	12	219CO3264	1/2"	.5000	6"	4-1/2"	6
219CO1864	9/32"	.2812	4-1/4"	2-15/16"	12						

- ◆ Jobber Length
- ◆ 135° Split Point
- ◆ Ground Flute
- ◆ Straight Shank
- ◆ Heavy Duty Web
- ◆ Gold Finish
- ◆ M35 Cobalt



COBALT

Cobalt Wire Gauge Drills - HEAVY DUTY - M35 COBALT

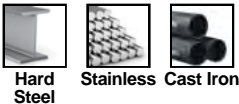

Part #	Size	Dec.	OAL	Flute	Qty.	Part #	Size	Dec.	OAL	Flute	Qty.
220CO0001	1	.2280	3-7/8"	2-5/8"	12	220CO0031	31	.1200	2-3/4"	1-5/8"	12
220CO0002	2	.2210	3-7/8"	2-5/8"	12	220CO0032	32	.1160	2-3/4"	1-5/8"	12
220CO0003	3	.2130	3-3/4"	2-1/2"	12	220CO0033	33	.1130	2-5/8"	1-1/2"	12
220CO0004	4	.2090	3-3/4"	2-1/2"	12	220CO0034	34	.1110	2-5/8"	1-1/2"	12
220CO0005	5	.2055	3-3/4"	2-1/2"	12	220CO0035	35	.1100	2-5/8"	1-1/2"	12
220CO0006	6	.2040	3-3/4"	2-1/2"	12	220CO0036	36	.1065	2-1/2"	1-7/16"	12
220CO0007	7	.2010	3-5/8"	2-7/16"	12	220CO0037	37	.1040	2-1/2"	1-7/16"	12
220CO0008	8	.1990	3-5/8"	2-7/16"	12	220CO0038	38	.1015	2-1/2"	1-7/16"	12
220CO0009	9	.1960	3-5/8"	2-7/16"	12	220CO0039	39	.0995	2-3/8"	1-3/8"	12
220CO0010	10	.1935	3-5/8"	2-7/16"	12	220CO0040	40	.0980	2-3/8"	1-3/8"	12
220CO0011	11	.1910	3-1/2"	2-5/16"	12	220CO0041	41	.0960	2-3/8"	1-3/8"	12
220CO0012	12	.1890	3-1/2"	2-5/16"	12	220CO0042	42	.0935	2-1/4"	1-1/4"	12
220CO0013	13	.1850	3-1/2"	2-5/16"	12	220CO0043	43	.0890	2-1/4"	1-1/4"	12
220CO0014	14	.1820	3-3/8"	2-3/16"	12	220CO0044	44	.0860	2-1/8"	1-1/8"	12
220CO0015	15	.1800	3-3/8"	2-3/16"	12	220CO0045	45	.0820	2-1/8"	1-1/8"	12
220CO0016	16	.1770	3-3/8"	2-3/16"	12	220CO0046	46	.0810	2-1/8"	1-1/8"	12
220CO0017	17	.1730	3-3/8"	2-3/16"	12	220CO0047	47	.0785	2"	1"	12
220CO0018	18	.1695	3-1/4"	2-1/8"	12	220CO0048	48	.0760	2"	1"	12
220CO0019	19	.1660	3-1/4"	2-1/8"	12	220CO0049	49	.0730	2"	1"	12
220CO0020	20	.1610	3-1/4"	2-1/8"	12	220CO0050	50	.0700	2"	1"	12
220CO0021	21	.1590	3-1/4"	2-1/8"	12	220CO0051	51	.0670	2"	1"	12
220CO0022	22	.1570	3-1/8"	2"	12	220CO0052	52	.0635	1-7/8"	7/8"	12
220CO0023	23	.1540	3-1/8"	2"	12	220CO0053	53	.0595	1-7/8"	7/8"	12
220CO0024	24	.1520	3-1/8"	2"	12	220CO0054	54	.0550	1-7/8"	7/8"	12
220CO0025	25	.1495	3"	1-7/8"	12	220CO0055	55	.0520	1-7/8"	7/8"	12
220CO0026	26	.1470	3"	1-7/8"	12	220CO0056	56	.0465	1-3/4"	3/4"	12
220CO0027	27	.1440	3"	1-7/8"	12	220CO0057	57	.0430	1-3/4"	3/4"	12
220CO0028	28	.1405	2-7/8"	1-3/4"	12	220CO0058	58	.0420	1-5/8"	11/16"	12
220CO0029	29	.1360	2-7/8"	1-3/4"	12	220CO0059	59	.0410	1-5/8"	11/16"	12
220CO0030	30	.1285	2-3/4"	1-5/8"	12	220CO0060	60	.0400	1-5/8"	11/16"	12

- ◆ Wire Gauge
- ◆ 135° Split Point
- ◆ Ground Flute
- ◆ Straight Shank
- ◆ Heavy Duty Web
- ◆ Gold Finish
- ◆ M35 Cobalt



NOTE:
SIZES 40 → 60
HAVE NO
SPLIT POINT.



COBALT

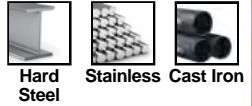

◆ Same as 219CO with 3/8" Shank.



COBALT

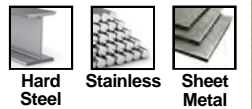

- ◆ Stub Length
- ◆ 135° Split Point
- ◆ Ground Flute
- ◆ Straight Shank
- ◆ Heavy Duty Web
- ◆ Gold Finish
- ◆ M35 Cobalt



COBALT



- ◆ 6" Length
- ◆ 118° Split Point
- ◆ Ground Flute
- ◆ 3-Flat Round 1/2" Shank
- ◆ Gold Finish
- ◆ M35 Cobalt



Cobalt Jobber Drills - 3/8" Shank - M35 COBALT

Part #	Size	Dec.	OAL	Flute	Qty.	Part #	Size	Dec.	OAL	Flute	Qty.
219R82564	25/64"	.3906	5-1/8"	3-3/4"	6	219R82964	29/64"	.4531	5-5/8"	4-3/16"	6
219R82664	13/32"	.4062	5-1/4"	3-1/8"	6	219R83064	15/32"	.4688	5-3/4"	4-5/16"	6
219R82764	27/64"	.4219	5-3/8"	3-15/16"	6	219R83164	31/64"	.4844	5-7/8"	4-3/8"	6
219R82864	7/16"	.4375	5-1/2"	4-1/16"	6	219R83264	1/2"	.5000	6"	4-1/2"	6



Cobalt Stub Fractional - M35 COBALT

Part #	Size	Dec.	OAL	Flute	Qty.	Part #	Size	Dec.	OAL	Flute	Qty.
CTS-0464	1/16"	.0625	1-5/8"	5/8"	12	CTS-1964	19/64"	.2969	2-3/4"	1-9/16"	12
CTS-0564	5/64"	.0781	1-11/16"	11/16"	12	CTS-2064	5/16"	.3125	2-13/16"	1-5/8"	12
CTS-0664	3/32"	.0938	1-3/4"	3/4"	12	CTS-2164	21/64"	.3281	2-15/16"	1-11/16"	6
CTS-0764	7/64"	.1094	1-13/16"	13/16"	12	CTS-2264	11/32"	.3438	3"	1-11/16"	6
CTS-0864	1/8"	.1250	1-7/8"	7/8"	12	CTS-2364	23/64"	.3594	3-1/16"	1-3/4"	6
CTS-0964	9/64"	.1406	1-15/16"	15/16"	12	CTS-2464	3/8"	.3750	3-1/8"	1-13/16"	6
CTS-1064	5/32"	.1562	2-1/16"	1"	12	CTS-2564	25/64"	.3906	3-1/4"	1-7/8"	6
CTS-1164	11/64"	.1719	2-1/8"	1-1/16"	12	CTS-2664	13/32"	.4062	3-5/16"	1-15/16"	6
CTS-1264	3/16"	.1875	2-3/16"	1-1/8"	12	CTS-2764	27/64"	.4219	3-3/8"	2"	6
CTS-1364	13/64"	.2031	2-1/4"	1-3/16"	12	CTS-2864	7/16"	.4375	3-7/16"	2-1/16"	6
CTS-1464	7/32"	.2188	2-3/8"	1-1/4"	12	CTS-2964	29/64"	.4531	3-9/16"	2-1/8"	6
CTS-1564	15/64"	.2344	2-7/16"	1-5/16"	12	CTS-3064	15/32"	.4688	3-5/8"	2-1/8"	6
CTS-1664	1/4"	.2500	2-1/2"	1-3/8"	12	CTS-3164	31/64"	.4844	3-11/16"	2-3/16"	6
CTS-1764	17/64"	.2656	2-5/8"	1-7/16"	12	CTS-3264	1/2"	.5000	3-3/4"	2-1/4"	6
CTS-1864	9/32"	.2812	2-11/16"	1-1/2"	12						



Cobalt Silver & Deming - 1/2" Shank - M35 COBALT

Part #	Size	Dec.	OAL	Flute	Qty.	Part #	Size	Dec.	OAL	Flute	Qty.
201CO3464	17/32"	.5312	6	2-3/4"	1	201CO5864	29/32"	.9062	6	2-3/4"	1
201CO3664	9/16"	.5625	6	2-3/4"	1	201CO6064	15/16"	.9375	6	2-3/4"	1
201CO3864	19/32"	.5938	6	2-3/4"	1	201CO6264	31/32"	.9688	6	2-3/4"	1
201CO4064	5/8"	.6250	6	2-3/4"	1	201CO6464	1"	1.0000	6	2-3/4"	1
201CO4264	21/32"	.6562	6	2-3/4"	1	201CO6864	1-1/16"	1.0625	6	2-3/4"	1
201CO4464	11/16"	.6875	6	2-3/4"	1	201CO7264	1-1/8"	1.1250	6	2-3/4"	1
201CO4664	23/32"	.7188	6	2-3/4"	1	201CO7664	1-3/16"	1.1875	6	2-3/4"	1
201CO4864	3/4"	.7500	6	2-3/4"	1	201CO8064	1-1/4"	1.2500	6	2-3/4"	1
201CO5064	25/32"	.7812	6	2-3/4"	1	201CO8464	1-5/16"	1.3125	6	2-3/4"	1
201CO5264	13/16"	.8125	6	2-3/4"	1	201CO8864	1-3/8"	1.3750	6	2-3/4"	1
201CO5464	27/32"	.8438	6	2-3/4"	1	201CO9664	1-1/2"	1.5000	6	2-3/4"	1
201CO5664	7/8"	.8750	6	2-3/4"	1						



INTERNATIONAL TOOL MANUFACTURING

150 Express St. Plainview, NY 11803

(516) 738-0388 • (800) 247-5696

ITM Fax (516) 279-1106



TITANIUM

Titanium Jobber Drills - (TiN) Coating - M2 HSS



Part #	Size	Dec.	OAL	Flute	Qty.	Part #	Size	Dec.	OAL	Flute	Qty.
255SP0464	1/16"	.0625	1-7/8"	7/8"	12	255SP1964	19/64"	.2969	4-3/8"	3-1/16"	12
255SP0564	5/64"	.0781	2"	1"	12	255SP2064	5/16"	.3125	4-1/2"	3-3/16"	12
255SP0664	3/32"	.0938	2-1/4"	1-1/4"	12	255SP2164	21/64"	.3281	4-5/8"	3-5/16"	6
255SP0764	7/64"	.1094	2-5/8"	1-1/2"	12	255SP2264	11/32"	.3438	4-3/4"	3-7/16"	6
255SP0864	1/8"	.1250	2-3/4"	1-5/8"	12	255SP2364	23/64"	.3594	4-7/8"	3-1/2"	6
255SP0964	9/64"	.1406	2-7/8"	1-3/4"	12	255SP2464	3/8"	.3750	5"	3-5/8"	6
255SP1064	5/32"	.1562	3-1/8"	2"	12	255SP2564	25/64"	.3906	5-1/8"	3-3/4"	6
255SP1164	11/64"	.1719	3-1/4"	2-1/8"	12	255SP2664	13/32"	.4062	5-1/4"	3-7/8"	6
255SP1264	3/16"	.1875	3-1/2"	2-5/16"	12	255SP2764	27/64"	.4219	5-3/8"	3-15/16"	6
255SP1364	13/64"	.2031	3-5/8"	2-7/16"	12	255SP2864	7/16"	.4375	5-1/2"	4-1/16"	6
255SP1464	7/32"	.2188	3-3/4"	2-1/2"	12	255SP2964	29/64"	.4531	5-5/8"	4-3/16"	6
255SP1564	15/64"	.2344	3-7/8"	2-5/8"	12	255SP3064	15/32"	.4688	5-3/4"	4-5/16"	6
255SP1664	1/4"	.2500	4"	2-3/4"	12	255SP3164	31/64"	.4844	5-7/8"	4-3/8"	6
255SP1764	17/64"	.2656	4-1/8"	2-7/8"	12	255SP3264	1/2"	.5000	6"	4-1/2"	6
255SP1864	9/32"	.2812	4-1/4"	2-15/16"	12						

- ◆ Jobber Length
- ◆ 135° Split Point
- ◆ Ground Flute
- ◆ Straight Shank
- ◆ Heavy Duty Web
- ◆ TiN Coating
- ◆ M2 HSS



IMPACT
1/4" HEX IMPACT SHANK



TITANIUM

1/4" Hex Titanium Jobber Drills - (TiN) Coating - M2 HSS



Part #	Size	Dec.	OAL	Flute	Qty.	Part #	Size	Dec.	OAL	Flute	Qty.
255HEX0464	1/16"	.0625	1-7/8"	7/8"	12	255HEX1664	1/4"	.2500	4"	2-3/4"	12
255HEX0664	3/32"	.0938	2-1/4"	1-1/4"	12	255HEX1864	9/32"	.2812	4-1/4"	2-15/16"	12
255HEX0864	1/8"	.1250	2-3/4"	1-5/8"	12	255HEX2064	5/16"	.3125	4-1/2"	3-3/16"	12
255HEX1064	5/32"	.1562	3-1/8"	2"	12	255HEX2464	3/8"	.3750	5"	3-5/8"	6
255HEX1264	3/16"	.1875	3-1/2"	2-5/16"	12	255HEX2864	7/16"	.4375	5-1/2"	4-1/16"	6
255HEX1464	7/32"	.2188	3-3/4"	2-1/2"	12	255HEX3264	1/2"	.5000	6"	4-1/2"	6

- ◆ 1/4" Hex Impact Shank
- ◆ Jobber Length
- ◆ 135° Split Point
- ◆ 1 Pc. Construction >3/16"
- ◆ Ground Flute
- ◆ Heavy Duty Web
- ◆ TiN Coating
- ◆ M2 HSS

1-PC on a Retail Clip



SOLD ON RETAIL CLIP.

1/4" Hex Titanium Jobber Drills - (TiN) Coating - M2 HSS

Part #	Size	Dec.	OAL	Flute	Qty.	Part #	Size	Dec.	OAL	Flute	Qty.
255H04	1/16"	.0625	1-7/8"	7/8"	1	255H16	1/4"	.2500	4"	2-3/4"	1
255H06	3/32"	.0938	2-1/4"	1-1/4"	1	255H18	9/32"	.2812	4-1/4"	2-15/16"	1
255H08	1/8"	.1250	2-3/4"	1-5/8"	1	255H20	5/16"	.3125	4-1/2"	3-3/16"	1
255H10	5/32"	.1562	3-1/8"	2"	1	255H24	3/8"	.3750	5"	3-5/8"	1
255H12	3/16"	.1875	3-1/2"	2-5/16"	1	255H28	7/16"	.4375	5-1/2"	4-1/16"	1
255H14	7/32"	.2188	3-3/4"	2-1/2"	1	255H32	1/2"	.5000	6"	4-1/2"	1



Rack P. 126



Parabolic Jobber Drills - SUPER HEAVY DUTY - M2 HSS

BLACK-GOLD

Part #	Size	Dec.	OAL	Flute	Qty.
PB-0464	1/16"	.0625	1-7/8"	7/8"	12
PB-0564	5/64"	.0781	2"	1"	12
PB-0664	3/32"	.0938	2-1/4"	1-1/4"	12
PB-0764	7/64"	.1094	2-5/8"	1-1/2"	12
PB-0864	1/8"	.1250	2-3/4"	1-5/8"	12
PB-0964	9/64"	.1406	2-7/8"	1-3/4"	12
PB-1064	5/32"	.1562	3-1/8"	2"	12
PB-1164	11/64"	.1719	3-1/4"	2-1/8"	12
PB-1264	3/16"	.1875	3-1/2"	2-5/16"	12
PB-1364	13/64"	.2031	3-5/8"	2-7/16"	12
PB-1464	7/32"	.2188	3-3/4"	2-1/2"	12
PB-1564	15/64"	.2344	3-7/8"	2-5/8"	12
PB-1664	1/4"	.2500	4"	2-3/4"	12
PB-1764	17/64"	.2656	4-1/8"	2-7/8"	12
PB-1864	9/32"	.2812	4-1/4"	2-15/16"	12

Part #	Size	Dec.	OAL	Flute	Qty.
PB-1964	19/64"	.2969	4-3/8"	3-1/16"	12
PB-2064	5/16"	.3125	4-1/2"	3-3/16"	12
PB-2164	21/64"	.3281	4-5/8"	3-5/16"	6
PB-2264	11/32"	.3438	4-3/4"	3-7/16"	6
PB-2364	23/64"	.3594	4-7/8"	3-1/2"	6
PB-2464	3/8"	.3750	5"	3-5/8"	6
PB-2564	25/64"	.3906	5-1/8"	3-3/4"	6
PB-2664	13/32"	.4062	5-1/4"	3-7/8"	6
PB-2764	27/64"	.4219	5-3/8"	3-15/16"	6
PB-2864	7/16"	.4375	5-1/2"	4-1/16"	6
PB-2964	29/64"	.4531	5-5/8"	4-3/16"	6
PB-3064	15/32"	.4688	5-3/4"	4-5/16"	6
PB-3164	31/64"	.4844	5-7/8"	4-3/8"	6
PB-3264	1/2"	.5000	6"	4-1/2"	6



- ◆ Jobber Length
- ◆ 135° Split Point
- ◆ Ground Flute
- ◆ Straight Shank
- ◆ Heavy Duty Web
- ◆ Black & Gold Finish
- ◆ M2 HSS



Extra Heavy Duty Web
30% thicker than even heavy duty webs, resists the extra shear stress found in deep hole drilling.

Parabolic Flute
Fast parabolic spiral allows deep hole drilling without frequent drill removal to clear chips.



Cobalt Jobber Drills - SUPER HEAVY DUTY - M42 SUPER COBALT



COBALT

Part #	Size	Dec.	OAL	Flute	Qty.
CO-0464	1/16"	.0625	1-7/8"	7/8"	12
CO-0564	5/64"	.0781	2"	1"	12
CO-0664	3/32"	.0938	2-1/4"	1-1/4"	12
CO-0764	7/64"	.1094	2-5/8"	1-1/2"	12
CO-0864	1/8"	.1250	2-3/4"	1-5/8"	12
CO-0964	9/64"	.1406	2-7/8"	1-3/4"	12
CO-1064	5/32"	.1562	3-1/8"	2"	12
CO-1164	11/64"	.1719	3-1/4"	2-1/8"	12
CO-1264	3/16"	.1875	3-1/2"	2-5/16"	12
CO-1364	13/64"	.2031	3-5/8"	2-7/16"	12
CO-1464	7/32"	.2188	3-3/4"	2-1/2"	12
CO-1564	15/64"	.2344	3-7/8"	2-5/8"	12
CO-1664	1/4"	.2500	4"	2-3/4"	12
CO-1764	17/64"	.2656	4-1/8"	2-7/8"	12
CO-1864	9/32"	.2812	4-1/4"	2-15/16"	12

Part #	Size	Dec.	OAL	Flute	Qty.
CO-1964	19/64"	.2969	4-3/8"	3-1/16"	12
CO-2064	5/16"	.3125	4-1/2"	3-3/16"	12
CO-2164	21/64"	.3281	4-5/8"	3-5/16"	6
CO-2264	11/32"	.3438	4-3/4"	3-7/16"	6
CO-2364	23/64"	.3594	4-7/8"	3-1/2"	6
CO-2464	3/8"	.3750	5"	3-5/8"	6
CO-2564	25/64"	.3906	5-1/8"	3-3/4"	6
CO-2664	13/32"	.4062	5-1/4"	3-7/8"	6
CO-2764	27/64"	.4219	5-3/8"	3-15/16"	6
CO-2864	7/16"	.4375	5-1/2"	4-1/16"	6
CO-2964	29/64"	.4531	5-5/8"	4-3/16"	6
CO-3064	15/32"	.4688	5-3/4"	4-5/16"	6
CO-3164	31/64"	.4844	5-7/8"	4-3/8"	6
CO-3264	1/2"	.5000	6"	4-1/2"	6

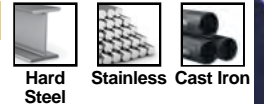

- ◆ Jobber Length
- ◆ 135° Split Point
- ◆ Ground Flute
- ◆ Straight Shank
- ◆ Heavy Duty Web
- ◆ Gold Finish
- ◆ M42 Super Cobalt





Made In



COBALT



- ◆ Heavy Duty Spur
- ◆ M42 Super Cobalt
- ◆ High Red Hot Hardness
- ◆ Double End
- ◆ Gold Finish



Spotweld - Double End - M42 COBALT

Part #	Size	Frac.	OAL	Qty.
219DE0065	6.5 mm	1/4"	3-5/8"	5
219DE0080	8.0 mm	5/16"	3-5/8"	5
219DE0100	10.0 mm	3/8"	3-5/8"	5



Double End - M42 COBALT

Part #	Size	Dec.	OAL	Flute	Qty.
211CO0864	1/8"	.1250	2"	1/2"	12
211CO0030	#30	.1285	2"	1/2"	12

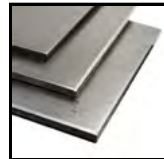

Sheet Metal



Double End - BRIGHT - M2 HSS

Part #	Size	Dec.	OAL	Flute	Qty.
211DE0764	7/64"	.1094	1-7/8"	1/2"	12
211DE0864	1/8"	.1250	2"	1/2"	12
211DE0964	9/64"	.1406	2"	1/2"	12
211DE1064	5/32"	.1562	2-1/16"	1/2"	12
211DE1264	3/16"	.1875	2-3/16"	1/2"	12
211DE1464	7/32"	.2188	2-3/8"	1/2"	12
211DE1664	1/4"	.2500	2-1/2"	1/2"	12
211DE0030	#30	.1285	2"	1/2"	12



Double End - BLACK - M2 HSS

Part #	Size	Dec.	OAL	Flute	Qty.
211DE0864-B	1/8"	.1250	2"	1/2"	12
211DE0030-B	#30	.1285	2"	1/2"	12

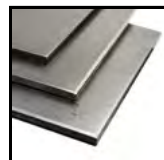

Sheet Metal

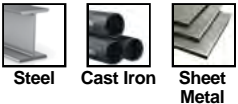

- ◆ Heavy Duty
- ◆ 135° Split Point
- ◆ M2 HSS
- ◆ Bright and Black Finish
- ◆ Automotive



Black & Gold VIP-STEP Jobber Drills - M2 HSS

Part #	Size	Dec.	OAL	Flute	Qty.	Part #	Size	Dec.	OAL	Flute	Qty.
VIP-1264	3/16"	.1875	3-1/2"	2-5/16"	12	VIP-2064	5/16"	.3125	4-1/2"	3-3/16"	12
VIP-1464	7/32"	.2188	3-3/4"	2-1/2"	12	VIP-2264	11/32"	.3438	4-3/4"	3-7/16"	6
VIP-1664	1/4"	.2500	4"	2-3/4"	12	VIP-2464	3/8"	.3750	5"	3-5/8"	6
VIP-1864	9/32"	.2812	4-1/4"	2-15/16"	12	VIP-2864	7/16"	.4375	5-1/2"	4-1/16"	6
						VIP-3264	1/2"	.5000	6"	4-1/2"	6



- ◆ Jobber Length
- ◆ 135° Step Point
- ◆ Ground Flute
- ◆ 3-Flat Shank
- ◆ Heavy Duty Web
- ◆ M2 HSS



Part # VIP-1 29 pc Bullet Set (Pg. 29)
VIP-1 is MRO-1F. 9 sizes above replace the key MRO sizes in set.

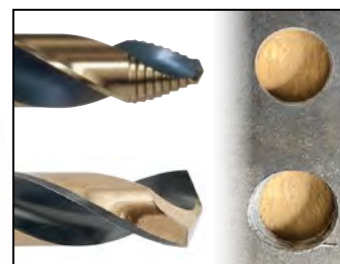



6" Cobalt Aircraft - M35 COBALT

Part #	Size	Dec.	OAL	Flute	Qty.
212CO0864	1/8"	.1250	6"	1-5/8"	6
212CO1064	5/32"	.1562	6"	2"	6
212CO1164	11/64"	.1719	6"	2-1/8"	6
212CO1264	3/16"	.1875	6"	2-5/16"	6
212CO1464	7/32"	.2188	6"	2-1/2"	6
212CO1664	1/4"	.2500	6"	2-3/4"	6
212CO2064	5/16"	.3125	6"	3-3/16"	1
212CO2464	3/8"	.3750	6"	3-5/8"	1



COBALT

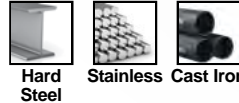

- ◆ Straight Shank
- ◆ 135° Split Point
- ◆ Ground Flute
- ◆ Extra Flexibility
- ◆ Heavy Duty Web
- ◆ Gold Finish
- ◆ M35 Cobalt



6" Aircraft - M2 HSS

Part #	Size	Dec.	OAL	Flute	Qty.
212SP0464	1/16"	.0625	6"	7/8"	6
212SP0864	1/8"	.1250	6"	1-5/8"	6
212SP0964	9/64"	.1406	6"	1-3/4"	6
212SP1064	5/32"	.1562	6"	2"	6
212SP1164	11/64"	.1719	6"	2-1/8"	6
212SP1264	3/16"	.1875	6"	2-5/16"	6
212SP1364	13/64"	.2031	6"	2-7/16"	6
212SP1464	7/32"	.2188	6"	2-1/2"	6
212SP1564	15/64"	.2344	6"	2-5/8"	6
212SP1664	1/4"	.2500	6"	2-3/4"	6
212SP1764	17/64"	.2656	6"	2-7/8"	6
212SP1864	9/32"	.2812	6"	2-15/16"	6
212SP2064	5/16"	.3125	6"	3-3/16"	1
212SP2264	11/32"	.3438	6"	3-7/16"	1
212SP2464	3/8"	.3750	6"	3-5/8"	1
212SP2864	7/16"	.4375	6"	4-1/16"	1
212SP3264	1/2"	.5000	6"	4-1/2"	1

18" Aircraft - M2 HSS

Part #	Size	Dec.	OAL	Flute	Qty.
215SP1264	3/16"	.1875	18"	2-5/16"	1
215SP1664	1/4"	.2500	18"	2-3/4"	1
215SP2064	5/16"	.3125	18"	3-3/16"	1
215SP2464	3/8"	.3750	18"	3-5/8"	1
215SP3264	1/2"	.5000	18"	4-1/2"	1

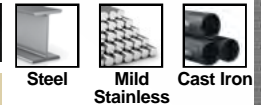

- ◆ Straight Shank
- ◆ 135° Split Point
- ◆ Ground Flute
- ◆ Extra Flexibility
- ◆ Heavy Duty Web
- ◆ Black Oxide Finish
- ◆ M2 HSS

6" Wire Gauge Aircraft - M2 HSS

Part #	Size	Dec.	OAL	Flute	Qty.
213SP0001	1	.2280	6"	2-5/8"	6
213SP0002	2	.2210	6"	2-5/8"	6
213SP0007	7	.2010	6"	2-7/16"	6
213SP0009	9	.1960	6"	2-7/16"	6
213SP0010	10	.1935	6"	2-7/16"	6
213SP0011	11	.1910	6"	2-5/16"	6
213SP0016	16	.1770	6"	2-3/16"	6
213SP0017	17	.1730	6"	2-3/16"	6
213SP0021	21	.1590	6"	2-1/8"	6
213SP0026	26	.1470	6"	1-7/8"	6
213SP0029	29	.1360	6"	1-3/4"	6
213SP0030	30	.1285	6"	1-5/8"	6
213SP0031	31	.1200	6"	1-5/8"	6
213SP0040	40	.0980	6"	1-3/8"	6



12" Aircraft - M2 HSS

Part #	Size	Dec.	OAL	Flute	Qty.
214SP0864	1/8"	.1250	12"	1-5/8"	1
214SP1064	5/32"	.1562	12"	2"	1
214SP1264	3/16"	.1875	12"	2-5/16"	1
214SP1464	7/32"	.2188	12"	2-1/2"	1
214SP1664	1/4"	.2500	12"	2-3/4"	1
214SP1864	9/32"	.2812	12"	2-15/16"	1
214SP2064	5/16"	.3125	12"	3-3/16"	1
214SP2264	11/32"	.3438	12"	3-7/16"	1
214SP2464	3/8"	.3750	12"	3-5/8"	1
214SP2864*	7/16"	.4375	12"	4-1/16"	1
214SP3264*	1/2"	.5000	12"	4-1/2"	1

* 3/8" Shank

12" Wire Gauge Aircraft - M2 HSS

Part #	Size	Dec.	OAL	Flute	Qty.
213SP1201	1	.2280	12"	2-5/8"	1
213SP1207	7	.2010	12"	2-7/16"	1
213SP1210	10	.1935	12"	2-7/16"	1
213SP1221	21	.1590	12"	2-1/8"	1
213SP1229	29	.1360	12"	1-3/4"	1
213SP1230	30	.1285	12"	1-5/8"	1
213SP1231	31	.1200	12"	1-5/8"	1
213SP1240	40	.0980	12"	1-3/8"	1



Long Boy - Full Body Spiral Drills P. 68



INTERNATIONAL TOOL MANUFACTURING

150 Express St. Plainview, NY 11803

(516) 738-0388 • (800) 247-5696

ITM® Fax (516) 279-1106

525 Pc. Dispenser Contains:

24- 1/16"	24- 5/64"	48- 3/32"	24- 7/64"	72- 1/8"
24- 9/64"	36- 5/32"	24- 11/64"	48- 3/16"	24- 13/64"
24- 7/32"	12- 15/64"	60- 1/4"	3- 17/64"	12- 9/32"
3- 19/64"	12- 5/16"	3- 21/64"	3- 11/32"	3- 23/64"
12- 3/8"	3- 25/64"	3- 13/32"	3- 27/64"	6- 7/16"
3- 29/64"	3- 15/32"	3- 31/64"	6- 1/2"	

This attractive drill bit merchandiser puts all 29 essential jobber sizes at your fingertips. Made of heavy duty steel construction, this deep red cabinet dispenser fits perfectly on any counter top. Comes with lock and key.



DISPLAY - PART# 13125

14" Out X 15"H X 12"W

525 PC Jobber Countertop Dispenser

Part #	Set	Sizes	Type	Drills	Point
SP-525	525 pc	1/16" → 1/2" x 64ths	Black Oxide	p.12	135° S.P.
BG-525	525 pc	1/16" → 1/2" x 64ths	Black & Gold	p.17	135° S.P.
MC-525	525 pc	1/16" → 1/2" x 64ths	Mechanics*	p.18	135° S.P.
MRO-525	525 pc	1/16" → 1/2" x 64ths	MRO 3-FLAT*	p.20	135° S.P.
CX-525	525 pc	1/16" → 1/2" x 64ths	Cobalt	p.22	135° S.P.

◆ Metal Huot Case



* Made in USA

S.P. = Split Point

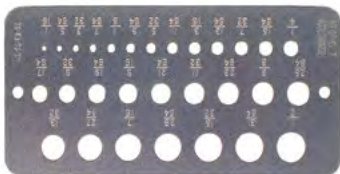

Metal Drill Gauges

Part #	Description	Sizes
29GAUGE	29 Hole Gauge	1/16" → 1/2"
60GAUGE	60 Hole Gauge	#1 → #60 Wire



◆ Metal Huot Case

TAP & DRILL Sets - M2 HSS TAPS

Part #	Sizes	Type	Drills	Point
TD-SP-019	See Below	M2 HSS Taps	p.12	135° S.P.

HSS DRILL BIT SIZES: #36, #29, #25, #21, #7, F, 5/16", U, 27/64"

HSS TAP SIZES: 6-32, 8-32, 10-24, 10-32, 1/4"-20, 5/16"-18, 3/8"-16, 7/16"-14, 1/2"-13



◆ Metal Huot Case

115 PC MASTER Sets - Straight Shank

Part #	Set	Sizes	Type	Drills	Point
SP-115	115 pc	See Below	Black Oxide	p.12	135° S.P.
BG-115	115 pc	See Below	Black & Gold	p.17	135° S.P.
CX-115	115 pc	See Below	Cobalt	p.22	135° S.P.

JOBBER SIZES: 1/16" → 1/2", WIRE GAUGE DRILL SIZES #1 → #60, LETTER SIZES: A → Z. STRAIGHT SHANK.

S.P. = Split Point



◆ Metal Huot Case

LETTER A → Z Sets - Straight Shank

Part #	Set	Sizes	Type	Drills	Point
SP-AZ	26 pc	A → Z	Black Oxide	p.13	135° S.P.
BG-AZ	26 pc	A → Z	Black & Gold	p.18	135° S.P.

S.P. = Split Point

29 PC Jobber Sets - Bullet Case

Part #	Set	Sizes	Type	Drills	Point
BX-1	29 pc	1/16" → 1/2" x 64ths	Black Oxide	p. 12	135° S.P.
BG-1	29 pc	1/16" → 1/2" x 64ths	Black & Gold	p. 17	135° S.P.
MC-1	29 pc	1/16" → 1/2" x 64ths	Mechanics 3-FLAT*	p. 18	135° S.P.
MRO-1F	29 pc	1/16" → 1/2" x 64ths	MRO 3-FLAT*	p. 20	135° S.P.
CX-1	29 pc	1/16" → 1/2" x 64ths	Cobalt	p. 22	135° S.P.
TI-1	29 pc	1/16" → 1/2" x 64ths	Titanium	p. 24	135° S.P.
CO-1	29 pc	1/16" → 1/2" x 64ths	Cobalt*	p. 25	135° S.P.
VIP-1	29 pc	1/16" → 1/2" x 64ths	VIP Step Jobber	p. 26	135° S.P.

◆ Huot Bullet Case



* Made in USA

S.P. = Split Point



29 PC Jobber Sets - Straight Shank

Part #	Set	Sizes	Type	Drills	Point
SP-29	29 pc	1/16" → 1/2" x 64ths	Black Oxide	p.12	135° S.P.
BG-29	29 pc	1/16" → 1/2" x 64ths	Black & Gold	p.17	135° S.P.
MRO-29F	29 pc	1/16" → 1/2" x 64ths	MRO 3-FLAT*	p.20	135° S.P.
CX-29	29 pc	1/16" → 1/2" x 64ths	Cobalt	p.22	135° S.P.
TI-29	29 pc	1/16" → 1/2" x 64ths	Titanium	p.24	135° S.P.
CO-29	29 pc	1/16" → 1/2" x 64ths	Cobalt*	p.25	135° S.P.

◆ Metal Huot Case



* Made in USA

S.P. = Split Point



8 PC Silver & Deming Sets

Part #	Set	Sizes	Type	Drills	Point
AD-8	8 pc	See Below	Black Oxide	p.15	118°
BG-8	8 pc	See Below	Black & Gold	p.19	118°
CX-8	8 pc	See Below	Cobalt	p.23	135° S.P.

ALL SETS: 9/16", 5/8", 11/16", 3/4", 13/16", 7/8", 15/16", 1"

◆ Metal Huot Case

S.P. = Split Point



60 PC Wire Gauge Sets

Part #	Set	Sizes	Type	Drills	Point
SP-60	60 pc	#1 → #60	Black Oxide	p.12	135° S.P.
BG-60	60 pc	#1 → #60	Black & Gold	p.17	135° S.P.
CX-60	60 pc	#1 → #60	Cobalt	p.22	135° S.P.

◆ Metal Huot Case

S.P. = Split Point





INTERNATIONAL TOOL MANUFACTURING

150 Express St. Plainview, NY 11803

(516) 738-0388 • (800) 247-5696

ITM® Fax (516) 279-1106



IMPACT
1/4" HEX IMPACT SHANK



- ◆ 1/4" Hex Impact Shank
- ◆ Outer Reamer
- ◆ Retail Packaging



Bar Champ - Small - M2 HSS

Part #	Description	Size	Qty.
BAR-01	Outer Reamer (HSS)	1/8" - 3/4"	1
DIS-07	Counter Display		1



BUY 7
BAR CHAMPS

GET THE
FREE DISPLAY

BAR CHAMP™

REPAIRING THREADED ROD TO FASTEN THE NUT

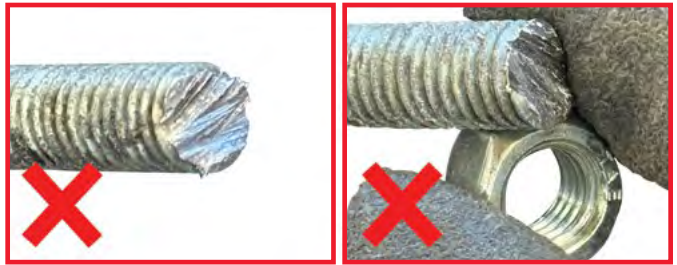



Bar Champ - Small - Carbide Blade

Part #	Description	Size	Qty.
BAR-01C	Outer Reamer (Carbide)	1/8" - 3/4"	1



- ◆ 1/4" Hex Impact Shank
- ◆ Outer Reamer
- ◆ Retail Packaging



Bar Champ - Medium - Carbide Blade

Part #	Description	Size	Qty.
BAR-02C	Outer Reamer (Carbide)	1/2" - 1-3/8"	1

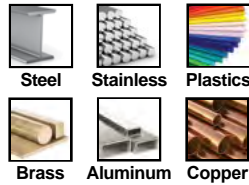

- ◆ 3/8" Hex Shank
- ◆ Outer Reamer
- ◆ Retail Packaging



Bar Champ - Large - Carbide Blade

Part #	Description	Size	Qty.
BAR-03C	Outer Reamer (Carbide)	1-3/8" - 2-1/8"	1



For Use With:

- Threaded Rod
- Round Stock
- Bar Stock
- Rebar
- Bolts



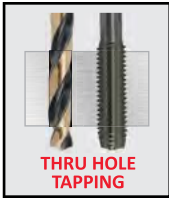

THRU HOLE TAPPING

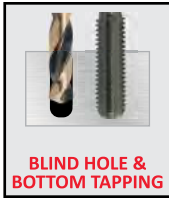

BLIND HOLE & BOTTOM TAPPING



TAP AND DRILL

NC = National Course
NF = National Fine

TAPER



8 to 10 threads chamfered for easy thread starting in tough materials.

MOST POPULAR STYLE TAP.

PLUG



3 to 5 threads chamfered for general use in thru holes or when tapping to bottom of hole is not critical.

BOTTOM



1-1/2 threads chamfered for use after threads have been started. Use for blind holes or clean tapping to bottom of holes.

DRILL THIS SIZE HOLE			
DECIMAL INCHES	DRILL SIZE	NEAREST FRACTION	TO TAP FOR THIS BOLT OR SCREW
.0469"	3/64"	3/64"	0-80 NF
.0595"	No. 53	none	1-64 NC
.0595"	No. 53	1/16"	1-72 NF
.0700"	No. 50	none	2-56 NC
.0700"	No. 50	none	2-64 NF
.0785"	No. 47	5/64"	3-48 NC
.0820"	No. 45	none	3-56 NF
.0860"	No. 44	none	4-36 NS
.0890"	No. 43	3/32"	4-40 NC
.0935"	No. 42	3/32"	4-48 NF
.0984"	2.5mm	none	3mm-0.60mm
.1015"	No. 38	none	1/8"-40 NS
.1015"	No. 38	none	5-40 NC
.1040"	No. 37	none	5-44 NF
.1100"	No. 35	7/64"	6-32 NC
.1110"	No. 34	none	6-36 NS
.1130"	No. 33	none	6-40 NF
.1200"	No. 31	none	6-48 NS
.1338"	3.4mm	none	4mm-0.70mm
.1338"	3.4mm	none	4mm-0.75mm
.1360"	No. 29	none	8-32 NC
.1360"	No. 29	9/64"	8-36 NF
.1405"	No. 28	none	8-40 NS
.1470"	No. 26	none	3/16"-24 NS
.1495"	No. 25	5/32"	10-24 NC
.1570"	No. 22	none	3/16"-32 NS
.1590"	No. 21	5/32"	10-32 NF
.1653"	4.2mm	none	5mm-0.90mm
.1693"	4.3mm	none	5mm-0.80mm
.1770"	No. 16	11/64"	12-24 NC
.1820"	No. 14	3/16"	12-28 NF
.1850"	No. 13	none	12-32 NEF
.1935"	No. 10	none	14-20 NS
.2010"	No. 7	13/64"	14"-20 NC
.2010"	No. 7	none	14-24 NS
.2047"	5.2mm	none	6mm-1.00mm
.2090"	No. 4	none	1/4"-24 NS
.2130"	No. 3	7/32"	1/4"-28 NF
.2188"	7/32"	7/32"	1/4"-32 NEF
.2280"	No. 1	none	1/4"-40 NS
.2401"	6.1mm	15/64"	7mm-1.00mm
.2570"	Ltr. F	17/64"	5/16"-18 NC
.2716"	6.9mm	17/64"	8mm-1.25mm
.2720"	Ltr. I	none	5/16"-24 NF
.2795"	7.1mm	none	8mm-1.00mm
.2812"	9/32"	9/32"	5/16"-32 NEF
.3110"	7.9mm	none	9mm-1.25mm
.3125"	5/16"	5/16"	3/8"-16 NC

DRILL THIS SIZE HOLE			
DECIMAL INCHES	DRILL SIZE	NEAREST FRACTION	TO TAP FOR THIS BOLT OR SCREW
.3189"	8.1mm	none	9mm-1.00mm
.3268"	8.3mm	none	9mm-0.75mm
.3320"	Ltr. Q	21/64"	3/8"-24 NF
.3425"	8.7mm	none	10mm-1.50mm
.3503"	8.9mm	11/32"	10mm-1.25mm
.3583"	9.1mm	none	*10mm-1.00mm
.3680"	Ltr. U	23/64"	7/16"-14 NC
.3818"	9.7mm	none	11mm-1.50mm
.3906"	25/64"	25/64"	7/16"-20 NF
.4133"	10.5mm	none	12mm-1.75mm
.4212"	10.7mm	27/64"	12mm-1.50mm
.4219"	27/64"	27/64"	1/2"-13 NC
.4291"	10.9mm	27/64"	*12mm-1.25mm
.4531"	29/64"	29/64"	1/2"-20 NF
.4531"	29/64"	29/64"	1/2"-24 NS
.4803"	12.2mm	none	14mm-2.00mm
.4844"	31/64"	31/64"	9/16"-12 NC
.4999"	12.7mm	none	14mm-1.50mm
.5039"	12.8mm	none	*14mm-1.25mm
.5156"	33/64"	33/64"	9/16"-18 NF
.5312"	17/32"	17/32"	5/8"-11 NC
.5590"	14.2mm	35/64"	16mm-2.00mm
.5781"	37/64"	37/64"	5/8"-18 NF
.5787"	14.7mm	none	16mm-1.50mm
.5938"	19/32"	19/32"	11/16"-11 NS
.6220"	15.8mm	39/64"	18mm-2.50mm
.6250"	5/8"	5/8"	11/16"-16 NS
.6562"	21/32"	21/32"	3/4"-10 NC
.6614"	16.8mm	none	*18mm-1.50mm
.6875"	11/16"	11/16"	3/4"-16 NF
.7008"	17.8mm	11/16"	20mm-2.50mm
.7656"	49/64"	49/64"	7/8"-9 NC
.8125"	13/16"	13/16"	7/8"-14 NF
.8228"	20.9mm	none	22mm-1.50mm
.8281"	53/64"	53/64"	*7/8"-18 NS
.8425"	21.4mm	53/64"	24mm-3.00mm
.8750"	7/8"	7/8"	1"-8 NC
.8779"	22.3mm	none	24mm-2.00mm
.9219"	59/64"	59/64"	1"-12 NF
.9375"	15/16"	15/16"	1"-14 NS
.9844"	63/64"	63/64"	1-1/8" - 7 NC
1.0469"	1-3/64"	1-3/64"	1-1/8" - 12 NF
1.1094"	1-7/64"	1-7/64"	1-1/4" - 7 NC
1.1719"	1-11/64"	1-11/64"	1-1/4" - 12 NF
1.2188"	1-7/32"	1-7/32"	1-3/8" - 6 NC
1.2969"	1-19/64"	1-19/64"	1-3/8" - 12 NF
1.3468"	1-11/32"	1-11/32"	1-1/2" - 6 NC
1.4219"	1-27/64"	1-27/64"	1-1/2" - 12 NF

* Spark Plug Taps.



Wrenches will accommodate all HSS within O.D. size.
O.D. Size = Actual Tap Size (machine screw thread).

** = 5 PC. PER PACK FROM 4-40 → 1/2"-20.
SOLD MULTIPLES OF 10.
* = SOLD 1 PC. OVER 1/2" - 20

High Speed Steel Hand Taps - MACHINE SCREW GROUND THREAD - *M2 HSS*

PART # TAPER	PART # PLUG	PART # BOTTOM	Machine Screw Thread	No. Of Flutes	Ground Thread Limit	OAL	Use Thread Length	Drill Size	
262NC0004	263NC0004	264NC0004	4-40 NC	3	H2	1-7/8"	9/16"	43	**
262NF0004	263NF0004	264NF0004	4-48 NF	3	H2	1-7/8"	9/16"	42	**
262NC0005	263NC0005	264NC0005	5-40 NC	3	H2	1-15/16"	7/8"	38	**
262NF0005	263NF0005	264NF0005	5-44 NF	3	H2	1-15/16"	7/8"	37	**
262NC0006	263NC0006	264NC0006	6-32 NC	3	H2	2"	11/16"	35	**
262NF0006	263NF0006	264NF0006	6-40 NF	3	H2	2"	11/16"	33	**
262NC0008	263NC0008	264NC0008	8-32 NC	4	H3	2-1/8"	3/4"	29	**
262NF0008	263NF0008	264NF0008	8-36 NF	4	H3	2-1/8"	3/4"	29	**
262NC0010	263NC0010	264NC0010	10-24 NC	4	H3	2-3/8"	7/8"	25	**
262NF0010	263NF0010	264NF0010	10-32 NF	4	H3	2-3/8"	7/8"	21	**
262NC0012	263NC0012	264NC0012	12-24 NC	4	H3	2-3/8"	15/16"	16	**
262NF0012	263NF0012	264NF0012	12-28 NF	4	H3	2-3/8"	15/16"	14	**



High Speed Steel Hand Taps - FRACTIONAL GROUND THREAD - *M2 HSS*

PART # TAPER	PART # PLUG	PART # BOTTOM	Fractional Screw Thread	No. Of Flutes	Ground Thread Limit	OAL	Use Thread Length	Drill Size	
265NC0310	266NC0310	267NC0310	1/4"-20 NC	4	H3	2-1/2"	1"	7	**
265NF0312	266NF0312	267NF0312	1/4"-28 NF	4	H3	2-1/2"	1"	3	**
265NC0315	266NC0315	267NC0315	5/16"-18 NC	4	H3	2-23/32"	1-1/8"	F	**
265NF0316	266NF0316	267NF0316	5/16"-24 NF	4	H3	2-23/32"	1-1/8"	I	**
265NC0318	266NC0318	267NC0318	3/8"-16 NC	4	H3	2-15/16"	1-1/4"	5/16"	**
265NF0319	266NF0319	267NF0319	3/8"-24 NF	4	H3	2-15/16"	1-1/4"	Q	**
265NC0320	266NC0320	267NC0320	7/16"-14 NC	4	H3	3-5/32"	1-7/16"	U	**
265NF0321	266NF0321	267NF0321	7/16"-20 NF	4	H3	3-5/32"	1-7/16"	25/64"	**
265NC0322	266NC0322	267NC0322	1/2"-13 NC	4	H3	3-3/8"	1-21/32"	27/64"	**
265NF0323	266NF0323	267NF0323	1/2"-20 NF	4	H3	3-3/8"	1-21/32"	29/64"	**
265NC0325	266NC0325	267NC0325	9/16"-12 NC	4	H3	3-19/32"	1-21/32"	31/64"	*
265NF0326	266NF0326	267NF0326	9/16"-18 NF	4	H3	3-19/32"	1-21/32"	33/64"	*
265NC0327	266NC0327	267NC0327	5/8"-11 NC	4	H3	3-13/16"	1-13/16"	17/32"	*
265NF0328	266NF0328	267NF0328	5/8"-18 NF	4	H3	3-13/16"	1-13/16"	37/64"	*
265NS0329	266NS0329	267NS0329	11/16"-11 NS	4	H3	4-1/32"	1-13/16"	19/32"	*
265NS0330	266NS0330	267NS0330	11/16"-16 NS	4	H3	4-1/32"	1-13/16"	5/8"	*
265NC0331	266NC0331	267NC0331	3/4"-10 NC	4	H3	4-1/4"	2"	21/32"	*
265NF0332	266NF0332	267NF0332	3/4"-16 NF	4	H3	4-1/4"	2"	11/16"	*
265NC0333	266NC0333	267NC0333	7/8"-9 NC	4	H4	4-11/16"	2-7/32"	49/64"	*
265NF0334	266NF0334	267NF0334	7/8"-14 NF	4	H4	4-11/16"	2-7/32"	13/16"	*
265NC0335	266NC0335	267NC0335	1"-8 NC	4	H4	5-1/8"	2-1/2"	7/8"	*
265NF0336	266NF0336	267NF0336	1"-12 NF	4	H4	5-1/8"	2-1/2"	59/64"	*
265NS0337	266NS0337	267NS0337	1"-14 NS	4	H4	5-1/8"	2-1/2"	15/16"	*



Tap Reamer Wrench

Part #	O.D. Size	Size
270TW0000	#0-1/4"	TW0
270TW0004	#0-3/8"	TW4
270TW0005	#7-1/2"	TW5
270TW0006	#7-3/4"	TW6
270TW0007	1/4" → 1-1/8"	TW7

T-Handle Tap Wrench

Part #	O.D. Size
271TT0001	#0 - 1/4"
271TT0002	#10 - 1/2"

WRENCHES ARE SOLD INDIVIDUALLY IN A BOX.

** = 5 PC. PER PACK FROM 4-40 → 1/2"-20.
SOLD MULTIPLES OF 10.
 * = SOLD 1 PC. OVER 1/2" - 20



◆ M2 HSS
 ◆ Ground Thread
 ◆ Heavy Duty 33



Steel

Mild
Stainless

Cast Iron



Aluminum

- ◆ M2 HSS
- ◆ Ground Thread
- ◆ Heavy Duty

Spiral Point Taps are ideal for machine tapping through holes or blind holes with adequate bottom clearance.

SOLD IN PACKS OF 5.



Spiral Point (Gun) Taps - *M2 HSS*

Part #	Size	No. Of Flutes	OAL	Thread Length	Drill Size
265SP0632	6-32	2	2"	11/16"	35
265SP0832	8-32	2	2-1/8"	3/4"	29
265SP1024	10-24	2	2-3/8"	7/8"	25
265SP1032	10-32	2	2-3/8"	7/8"	25
265SP1224	12-24	2	2-3/8"	15/16"	16
265SP1420	1/4"-20	2	2-1/2"	1"	7
265SP1428	1/4"-28	2	2-1/2"	1"	7
265SP5618	5/16"-18	2	2-23/32"	1-1/8"	F
265SP3816	3/8"-16	3	2-15/16"	1-1/4"	5/16"
265SP1312	1/2"-13	3	3-3/8"	1-21/32"	27/64"



Steel

Mild
Stainless

Cast Iron



Aluminum

- ◆ M2 HSS
- ◆ Ground Thread
- ◆ Heavy Duty



Spiral Point Taps are ideal for machine tapping through holes or blind holes with adequate bottom clearance.

SOLD IN PACKS OF 5.



Spiral Point (Gun) Taps - *M2 HSS*

Part #	Size	No. Of Flutes	OAL	Thread Length	Drill Size
GUN-0632	6-32	2	2"	11/16"	35
GUN-0832	8-32	2	2-1/8"	3/4"	29
GUN-1024	10-24	2	2-3/8"	7/8"	25
GUN-1032	10-32	2	2-3/8"	7/8"	25
GUN-1224	12-24	2	2-3/8"	15/16"	16
GUN-1420	1/4"-20	2	2-1/2"	1"	7
GUN-1428	1/4"-28	2	2-1/2"	1"	7
GUN-5618	5/16"-18	2	2-23/32"	1-1/8"	F
GUN-3816	3/8"-16	3	2-15/16"	1-1/4"	5/16"
GUN-1312	1/2"-13	3	3-3/8"	1-21/32"	27/64"
GUN-3410	3/4"-10	3	3-3/8"	1-21/32"	27/64"



Steel

Mild
Stainless

Cast Iron



Aluminum

- ◆ M2 HSS
- ◆ Ground Thread
- ◆ Heavy Duty

Drill and Tap holes in one operation, saving a complete setup!

SOLD IN PACKS OF 5.



Combo Drill Taps - *M2 HSS*

Part #	Thread Size	Drill Size	Thread Length	OAL
266TD0632	6-32	0.1095	11/16"	2"
266TD0832	8-32	0.1360	3/4"	2-1/8"
266TD0836	8-36	0.1360	3/4"	2-1/8"
266TD1024	10-24	0.1520	7/8"	2-3/8"
266TD1032	10-32	0.1520	7/8"	2-3/8"
266TD1224	12-24	0.1770	15/16"	2-3/8"
267TD1420	1/4"-20	0.2010	15/16"	2-1/2"
267TD1428	1/4"-28	0.2010	15/16"	2-1/2"
267TD5618	5/16"-18	0.2570	1-1/8"	3"
267TD3816	3/8"-16	0.3125	1-1/4"	3-1/2"
267TD3824	3/8"-24	0.3125	1-1/4"	3-1/2"
267TD7614	7/16"-14	0.3680	1-7/16"	3-7/8"
267TD1213	1/2"-13	0.4250	1-21/32"	4-1/4"



3 in 1 Combo Drill Taps - M2 HSS

Part #	Thread Size	Drill Size	Thread Length	OAL
HDT-0632	6-32	0.0787	9/64"	2-1/4"
HDT-0832	8-32	0.0984	5/32"	2-1/4"
HDT-1024	10-24	0.1181	13/64"	2-1/4"
HDT-1032	10-32	0.1181	5/32"	2-23/64"
HDT-1224	12-24	0.1181	13/64"	2-23/64"
HDT-1420	1/4"-20	0.1574	1/4"	2-37/64"
HDT-5618	5/16"-18	0.1574	29/64"	3"
HDT-3816	3/8"-16	0.1968	15/32"	3-3/16"
HDT-1213	1/2"-13	0.3419	27/64"	3-13/32"



Copper Aluminum

- ◆ 1/4" Hex Impact Shank
- ◆ M2 HSS
- ◆ Ground Thread
- ◆ Fast Spiral Flute
- ◆ Tri-Point Tip
- ◆ Retail Packaging
- ◆ Sold Individually



1. DRILLING



2. TAPPING



3. CHAMFER



FAST SPIRAL FLUTE



RETAIL PACKAGING

3 in 1 Combo Drill Taps - 8 Pc. Kit

Part #	Description	Sizes
HDT-SET8	8 Pc. 3 in 1 Drill Tap Kit	6-32 - 1/2"-13



6-32



12-24



8-32



1/4"-20



10-24



3/8"-16



10-32



1/2"-13



Tri-Point Tip



- ◆ National Pipe Tap
- ◆ M2 HSS
- ◆ Ground Thread
- ◆ Heavy Duty

SOLD INDIVIDUALLY IN PLASTIC TUBES.

NPT Taper Pipe Taps - *M2 HSS*

Part #	Size	Threads Per Inch NPT Only	No. Of Flutes	OAL	Thread Length
265TP0464	1/16"	27	4	2-1/8"	11/16"
265TP0864	1/8"	27	4	2-1/8"	3/4"
265TP1664	1/4"	18	4	2-7/16"	1-1/16"
265TP2464	3/8"	18	4	2-9/16"	1-1/16"
265TP3264	1/2"	14	4	3-1/8"	1-3/8"
265TP4864	3/4"	14	5	3-1/4"	1-3/8"
265TP6464	1"	11.5	5	3-3/4"	1-3/4"
265TP8064	1-1/4"	11.5	5	4"	1-3/4"
265TP9664	1-1/2"	11.5	7	4-1/4"	1-3/4"
265TP9964	2"	11.5	7	4-1/2"	1-3/4"



- ◆ National Pipe Tap
- ◆ Carbon Steel
- ◆ Ground Thread
- ◆ General Purpose

SOLD INDIVIDUALLY IN PLASTIC TUBES.

(Carbon Steel) NPT Taper Pipe Taps

Part #	Size	Threads Per Inch NPT Only	No. Of Flutes	OAL	Thread Length
NPT0464	1/16"	27	4	2-1/8"	11/16"
NPT0864	1/8"	27	4	2-1/8"	3/4"
NPT1664	1/4"	18	4	2-7/16"	1-1/16"
NPT2464	3/8"	18	4	2-9/16"	1-1/16"
NPT3264	1/2"	14	4	3-1/8"	1-3/8"
NPT4864	3/4"	14	5	3-1/4"	1-3/8"
NPT6464	1"	11.5	5	3-3/4"	1-3/4"
NPT8864	1-1/4"	11.5	5	4"	1-3/4"
NPT9664	1-1/2"	11.5	7	4-1/4"	1-3/4"
NPT9964	2"	11.5	7	4-1/2"	1-3/4"



INTERNAL PIPE THREADING

NPT TAP-DRILL CHART

DRILL THIS SIZE HOLE			TO TAP FOR THIS BOLT OR SCREW
DECIMAL INCHES	DRILL SIZE	NEAREST FRACTION	
.3390"	Ltr. R	none	1/8-27 NPT
.4375"	7/16"	7/16"	1/4-18 NPT
.5781"	37/64"	37/64"	3/8- 18 NPT
.7031"	45/64"	45/64"	1/2-14 NPT
.9219"	59/64"	59/64"	3/4-14 NPT
1.1562"	1-5/32"	1-5/32"	1 - 11-1/2 NPT
1.5000"	1-1/2"	1-1/2"	1-1/4 - 11-1/2 NPT
1.7344"	1-47/64"	1-47/64"	1-1/2 - 11-1/2 NPT
2.2188"	2-3/16"	2-3/16"	2 - 11-1/2 NPT



Three (3) Flute Countersinks - M35 COBALT - 82°

Part #	Degree	Size	Shank	OAL
SK-82-2	82°	1/4"	HEX	1-1/2"
SK-82-4	82°	3/8"	1/4" HEX	1-1/2"
SK-82-5	82°	1/2"	1/4" HEX	1-1/2"
SK-82-7	82°	5/8"	1/4" HEX	1-1/2"
SK-82-8	82°	3/4"	1/4" HEX	1-1/2"

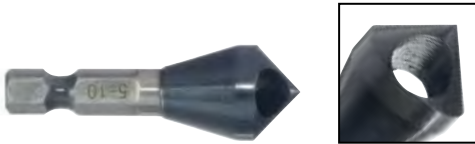

Zero Flute Countersinks - M35 COBALT - 82°

Part #	Degree	Screw Size	Body Dia.	Shank	OAL
SX-1	82°	No. 2, 3, 4	1/4"	1/4" HEX	1-1/4"
SX-2	82°	No. 5, 6, 8	11/32"	1/4" HEX	1-1/2"
SX-3	82°	No. 10, 12, 14	9/16"	1/4" HEX	1-3/4"



Rim Champ - 90° - M2 HSS

Part #	Description	Size	Shank	OAL
RIM-01	Inner Reamer (HSS)	1/8"- 3/4"	1/4" HEX	2"
RIM-02	Inner Reamer (HSS)	3/16"- 7/8"	1/4" HEX	2"



Screw Extractor - LEFT HAND SPIRAL FLUTE

Part #	Size	Shank Diameter	Removes Screws or	Pipe
SE0001	1	5/64"	3/32" to 5/32"	
SE0002	2	7/64"	5/32" to 7/32"	
SE0003	3	5/32"	7/32" to 9/32"	
SE0004	4	1/4"	9/32" to 3/8"	1/8" Pipe
SE0005	5	19/64"	3/8" to 5/8"	1/4" Pipe
SE0006	6	13/32"	5/8" to 7/8"	3/8" Pipe
SE0007	7	17/32"	7/8" to 1-1/8"	1/2" Pipe
SE0008	8	13/16"	1-1/8" to 1-3/8"	3/4" Pipe
SE0009	9	1-1/16"	1-3/8" to 2"	1" Pipe



Cylinder

Part #	Dia.	Cut	Qty.
CBA-1	1/4"	5/8"	1
CBA-3	3/8"	3/4"	1
CBA-5	1/2"	1"	1
CBA-7	3/4"	1"	1



Tree w/ Radius

Part #	Dia.	Cut	Qty.
CBF-1	1/4"	5/8"	1
CBF-3	3/8"	3/4"	1
CBF-5	1/2"	1"	1
CBF-6	5/8"	1"	1



14° Taper w/ Radius

Part #	Dia.	Cut	Qty.
CBL-1	1/4"	5/8"	1
CBL-3	3/8"	1-1/16"	1
CBL-4	1/2"	1-1/8"	1
CBL-5	5/8"	1-3/16"	1
CBL-7	3/4"	1-1/2"	1

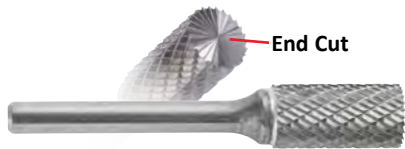

Cylinder w/ End Cut

Part #	Dia.	Cut	Qty.
CBB-1	1/4"	5/8"	1
CBB-3	3/8"	3/4"	1
CBB-5	1/2"	1"	1
CBB-7	3/4"	1"	1



Tree w/ Point

Part #	Dia.	Cut	Qty.
CBG-1	1/4"	5/8"	1
CBG-3	3/8"	3/4"	1
CBG-5	1/2"	1"	1



Pointed Cone

Part #	Dia.	Cut	Qty.
CBM-2	1/4"	3/4"	1
CBM-4	3/8"	5/8"	1
CBM-5	1/2"	7/8"	1



Cylinder w/ Radius

Part #	Dia.	Cut	Qty.
CBC-1	1/4"	5/8"	1
CBC-3	3/8"	3/4"	1
CBC-5	1/2"	1"	1
CBC-6	5/8"	1"	1



Flame

Part #	Dia.	Cut	Qty.
CBH-1	1/4"	1/2"	1
CBH-5	1/2"	1-1/4"	1



Inverted Cone

Part #	Dia.	Cut	Qty.
CBN-1	1/4"	5/16"	1
CBN-2	3/8"	3/8"	1
CBN-4	1/2"	1/2"	1

Made In



- ◆ Made In USA
- ◆ Solid Carbide
- ◆ Bright Finish
- ◆ Sold Individually



SOLD INDIVIDUALLY ONE PER TUBE.



Ball

Part #	Dia.	Cut	Qty.
CBD-1	1/4"	1/4"	1
CBD-3	3/8"	3/8"	1
CBD-5	1/2"	1/2"	1



Cone 60°

Part #	Dia.	Cut	Qty.
CBJ-1	1/4"	3/16"	1
CBJ-3	3/8"	1/4"	1
CBJ-5	1/2"	7/16"	1



Oval

Part #	Dia.	Cut	Qty.
CBE-1	1/4"	3/8"	1
CBE-3	3/8"	5/8"	1
CBE-5	1/2"	7/8"	1
CBE-6	5/8"	1"	1



Cone 90°

Part #	Dia.	Cut	Qty.
CBK-1	1/4"	1/4"	1
CBK-3	3/8"	3/8"	1
CBK-5	1/2"	1/2"	1



Cylinder

Part #	Dia.	Cut	Qty.
SA-1NF	1/4"	3/4"	1
SA-3NF	3/8"	3/4"	1
SA-5NF	1/2"	1"	1
SA-6NF	5/8"	1"	1
SA-7NF	3/4"	1"	1



Ball

Part #	Dia.	Cut	Qty.
SD-1NF	1/4"	1/4"	1
SD-3NF	3/8"	3/8"	1
SD-5NF	1/2"	1/2"	1
SD-6NF	5/8"	5/8"	1
SD-7NF	3/4"	3/4"	1



Tree w/ Radius

Part #	Dia.	Cut	Qty.
SF-1NF	1/4"	3/4"	1
SF-3NF	3/8"	3/4"	1
SF-5NF	1/2"	1"	1
SF-6NF	5/8"	1"	1
SF-14NF	3/4"	1-1/4"	1



Cylinder w/ Radius

Part #	Dia.	Cut	Qty.
SC-1NF	1/4"	3/4"	1
SC-3NF	3/8"	3/4"	1
SC-5NF	1/2"	1"	1
SC-6NF	5/8"	1"	1
SC-7NF	3/4"	1"	1



Oval

Part #	Dia.	Cut	Qty.
SE-3NF	3/8"	5/8"	1
SE-5NF	1/2"	7/8"	1
SE-6NF	5/8"	1"	1
SE-7NF	3/4"	1"	1



14° Taper w/ Radius

Part #	Dia.	Cut	Qty.
SL-3NF	3/8"	1-1/16"	1
SL-4NF	1/2"	1-1/8"	1
SL-6NF	5/8"	1-5/16"	1
SL-7NF	3/4"	1-1/2"	1



METAL HUOT CASE

8 Pc. Carbide Bur Set

Part #	Description	Qty.
CB-8	8 Pc Ferrous Metal Set	1



Part#	Dia.	Cut
CBA-1	1/4"	5/8"
CBA-5	1/2"	1"



Part#	Dia.	Cut
CBC-3	3/8"	3/4"
CBC-5	1/2"	1"



Part#	Dia.	Cut
CBD-1	1/4"	1/4"
CBD-5	1/2"	1/2"



Part#	Dia.	Cut
CBF-3	3/8"	3/4"
CBF-5	1/2"	1"



Made In



- ◆ Made In USA
- ◆ Solid Carbide
- ◆ Deep Flute
- ◆ Bright Finish
- ◆ Sold Individually

Non-Ferrous (Soft Metals)



- ◆ Solid Carbide
- ◆ Bright Finish

Made In



SOLID CARBIDE BURS



M2 HSS FAST SPIRAL

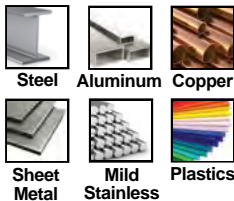

- ◆ 3/8" Hex Shank
- ◆ M2 HSS
- ◆ 2-Fast Spiral Flutes
- ◆ Jam Free Performance
- ◆ Self Starting Split Point
- ◆ Bright Finish
- ◆ Sold Individually



1/8"
5/32"
3/16"
7/32"
1/4"
9/32"
5/16"
11/32"
3/8"
13/32"
7/16"
15/32"
1/2"

274MC0001
13 Steps 1/8" - 1/2"



3/16"
1/4"
5/16"
3/8"
7/16"
1/2"

274MC0002
6 Steps 3/16" - 1/2"



3/16"
1/4"
5/16"
3/8"
7/16"
1/2"
9/16"
5/8"
11/16"
3/4"

274MC0003
10 Steps 3/16" - 3/4"



3/16"
1/4"
5/16"
3/8"
7/16"
1/2"
9/16"
5/8"
11/16"
3/4"
13/16"
7/8"

274MC0004
12 Steps 3/16" - 7/8"



7/16"
1/2"
9/16"
5/8"
11/16"
3/4"
13/16"
7/8"
15/16"
1"
1-1/16"
1-1/8"

274MC0005
12 Steps 7/16" - 1-1/8"



3/4"
13/16"
7/8"
15/16"
1"
1-1/16"
1-1/8"
1-3/16"
1-1/4"
1-5/16"
1-3/8"

274MC0006
11 Steps 3/4" - 1-3/8"



3/8"
7/16"
3/4"

274MC0007
3 Steps 3/8" - 3/4"

For drilling 3 standard size holes to accommodate drive screws for knockout punches.



3/16" STARTER POINT
7/8"
1-1/8"
7/8" hole for 1/2" conduit.
1-1/8" hole for 3/4" conduit.

274MC0008
2 Steps 7/8" - 1-1/8"



3/16" STARTER POINT
7/8"
1-1/8"
1-7/32"
1-1/4"
1-3/8"
1-7/32" hole for oil tight switches.

274MC0009
5 Steps 7/8" - 1-3/8"



7/8"

274MC0010
SMOOTH CONE-7/8"



ENHANCED THE BIG 11 One Size Fits All
3/16" Drilling Depth
3/16"
1/4"
3/8"
1/2"
5/8"
3/4"
7/8"
1"
1-1/8"
1-1/4"
1-3/8"

274MC0011
11 Steps 3/16" - 1-3/8"



ENHANCED THE BIG 11 One Size Fits All
3/16" Drilling Depth
3/16"
1/4"
3/8"
1/2"
5/8"
3/4"
7/8"
1"
1-1/8"
1-1/4"
1-3/8"

275MC-11
11 Steps 3/16" - 1-3/8"



M2 HSS FAST SPIRAL

- ◆ 1/4" Hex Impact Shank
- ◆ M2 HSS
- ◆ 2-Fast Spiral Flutes
- ◆ Jam Free Performance
- ◆ Self Starting Split Point
- ◆ Bright Finish
- ◆ Sold Individually



1/8"
5/32"
3/16"
7/32"
1/4"
9/32"
5/16"
11/32"
3/8"
13/32"
7/16"
15/32"
1/2"

274HEX01
13 Steps 1/8" - 1/2"



3/16"
1/4"
5/16"
3/8"
7/16"
1/2"

274HEX02
6 Steps 3/16" - 1/2"



3/16"
1/4"
5/16"
3/8"
7/16"
1/2"
9/16"
5/8"
11/16"
3/4"

274HEX03
10 Steps 3/16" - 3/4"



3/16"
1/4"
5/16"
3/8"
7/16"
1/2"
9/16"
5/8"
11/16"
3/4"
13/16"
7/8"

274HEX04
12 Steps 3/16" - 7/8"



7/16"
1/2"
9/16"
5/8"
11/16"
3/4"
13/16"
7/8"
15/16"
1"
1-1/16"
1-1/8"

274HEX05
12 Steps 7/16" - 1-1/8"



3/16" STARTER POINT
7/8"
1-1/8"
7/8" hole for 1/2" conduit.
1-1/8" hole for 3/4" conduit.

274HEX08
2 Steps 7/8" - 1-1/8"



XFLUTE

M35 CO-TIAlN COATING
FAST SPIRAL STEP DRILL

TiAlN

1/8"
5/32"
3/16"
7/32"
1/4"
9/32"
5/16"
11/32"
3/8"
13/32"
7/16"
15/32"
1/2"

7MC-01
13 Steps 1/8" - 1/2"

TiAlN

3/16"
1/4"
5/16"
3/8"
7/16"
1/2"

7MC-02
6 Steps 3/16" - 1/2"

TiAlN

1/4"
5/16"
3/8"
7/16"
1/2"
9/16"
5/8"
11/16"
3/4"

7MC-03
9 Steps 1/4" - 3/4"

TiAlN

3/16"
1/4"
5/16"
3/8"
7/16"
1/2"
9/16"
5/8"
11/16"
3/4"
13/16"
7/8"

7MC-04
12 Steps 3/16" - 7/8"

TiAlN

7/16"
1/2"
9/16"
5/8"
11/16"
3/4"
13/16"
7/8"
15/16"
1"
1-1/16"
1-1/8"

7MC-05
12 Steps 7/16" - 1-1/8"

TiAlN

3/4"
13/16"
7/8"
15/16"
1"
1-1/16"
1-1/8"
1-3/8"

7MC-06
11 Steps 3/4" - 1-3/8"

TiAlN

7/8"
1-1/8"

7/8" hole for 1/2" conduit.
1-1/8" hole for 3/4" conduit.

7MC-08
2 Steps 7/8" - 1-1/8"

TiAlN

1/8"
5/32"
3/16"
7/32"
1/4"
9/32"
5/16"
11/32"
3/8"
13/32"
7/16"
15/32"
1/2"

XSTP-01
13 Steps 1/8" - 1/2"

TiAlN

3/16"
1/4"
5/16"
3/8"
7/16"
1/2"

XSTP-02
6 Steps 3-16" - 1/2"

TiAlN

1/4"
5/16"
3/8"
7/16"
1/2"
9/16"
5/8"
11/16"
3/4"

XSTP-03
9 Steps 1/4" - 3/4"

TiAlN

3/16"
1/4"
5/16"
3/8"
7/16"
1/2"
9/16"
5/8"
11/16"
3/4"
13/16"
7/8"

XSTP-04
12 Steps 3/16" - 7/8"

TiAlN

7/16"
1/2"
9/16"
5/8"
11/16"
3/4"
13/16"
7/8"
15/16"
1"
1-1/16"
1-1/8"

XSTP-05
12 Steps 7/16" - 1-1/8"

TiAlN

7/8"
1-1/8"

7/8" hole for 1/2" conduit.
1-1/8" hole for 3/4" conduit.

XSTP-08
2 Steps 7/8" - 1-1/8"

TiAlN COATED

COBALT

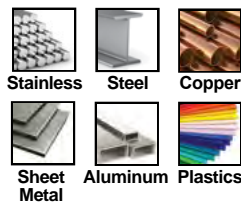

- ◆ 3/8" Hex Shank
- ◆ M35 Cobalt
- ◆ 4-Fast Spiral Flutes
- ◆ Great for Stainless
- ◆ Self Starting Split Point
- ◆ Titanium Aluminum Nitride Coating
- ◆ Sold Individually



TiAlN COATED

COBALT

- ◆ 1/4" Hex Impact Shank
- ◆ M35 Cobalt
- ◆ 4-Fast Spiral Flutes
- ◆ Great for Stainless
- ◆ Self Starting Split Point
- ◆ Titanium Aluminum Nitride Coating
- ◆ Sold Individually



IMPACT
1/4" HEX IMPACT SHANK



BLACK Oxide



Steel Stainless Cast Iron

- ◆ M2 HSS
- ◆ Tapered Point
- ◆ Left-Hand Spiral
- ◆ Right-Hand Cut
- ◆ 3-Flat Shank
- ◆ Made in Europe
- ◆ Sold Individually



1/2" DRILL

Reaming Steel For Aligning Existing Holes & Bolt / Rivet Installation

BLACK Oxide

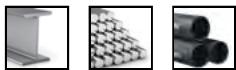

Steel Stainless Cast Iron

- ◆ M2 HSS
- ◆ Tapered Point
- ◆ Left-Hand Spiral
- ◆ Right-Hand Cut
- ◆ HEX Nut Shank
- ◆ Made in Europe
- ◆ Sold Individually



IMPACT WRENCH

Reaming Steel For Aligning Existing Holes & Bolt / Rivet Installation



3-FLAT SHANK

Reamer - CAR / Construction - Spiral Flute - M2 HSS

Part #	Size	Point Diameter	OAL	Flute	Shank	Type
CRF-2464	3/8"	0.250	5"	4"	3/8"	3-Flat Car / Constr.
CRF-2864	7/16"	0.281	5-1/4"	4"	7/16"	3-Flat Car / Constr.
CRF-3264	1/2"	0.343	6"	4-1/2"	1/2"	3-Flat Car / Constr.
CRF-3664	9/16"	0.343	6-1/4"	4-1/2"	1/2"	3-Flat Car / Constr.
CRF-4064	5/8"	0.343	6-1/2"	4-1/2"	1/2"	3-Flat Car / Constr.
CRF-4464	11/16"	0.375	7"	4-1/2"	1/2"	3-Flat Car / Constr.
CRF-4864	3/4"	0.406	7-1/4"	5"	1/2"	3-Flat Car / Constr.
CRF-5264	13/16"	0.468	7-1/4"	5"	1/2"	3-Flat Car / Constr.
CRF-5664	7/8"	0.500	7-1/4"	5"	1/2"	3-Flat Car / Constr.
CRF-6064	15/16"	0.585	7-1/4"	5"	1/2"	3-Flat Car / Constr.
CRF-6464	1"	0.594	7-1/4"	5"	1/2"	3-Flat Car / Constr.
CRF-6864	1-1/16"	0.807	7-1/4"	5"	1/2"	3-Flat Car / Constr.



Reamer - CAR/Construction - Spiral Flute - HEX - M2 HSS

Part #	Size	Point Diameter	OAL	Flute	Shank	Type
CHX-4464	11/16"	0.375	6-3/8"	4-1/2"	1-1/16"	HEX Car
CHX-5264	13/16"	0.468	7"	5"	1-1/4"	HEX Car
CHX-6064	15/16"	0.585	7"	5"	1-7/16"	HEX Car
CHX-6864	1-1/16"	0.807	7"	5"	1-5/8"	HEX Car



Reamer - BRIDGE - Spiral Flute - HEX - M2 HSS

Part #	Size	Point Diameter	OAL	Flute	Shank	Type
CBB-4464	11/16"	0.375	9-1/4"	7-1/8"	1-1/16"	HEX Bridge
CBB-5264	13/16"	0.468	9-3/8"	7-3/8"	1-1/4"	HEX Bridge
CBB-6064	15/16"	0.585	9-3/8"	7-3/8"	1-7/16"	HEX Bridge
CBB-6864	1-1/16"	0.807	9-3/8"	7-3/8"	1-5/8"	HEX Bridge
CBB-7064	1-3/16"	0.922	9-3/8"	7-3/8"	1-13/16"	HEX Bridge



Reaming Steel For Aligning Existing Holes & Bolt / Rivet Installation

Reamer - CAR / Construction - Spiral Flute - M2 HSS

Part #	Size	Point Diameter	OAL	Flute	Shank	Type
ASF-2464	3/8"	0.250	5"	4"	3/8"	3-Flat Car / Constr.
ASF-3264	1/2"	0.281	6"	4-1/2"	1/2"	3-Flat Car / Constr.
ASF-3664	9/16"	0.343	6-1/4"	4-1/2"	1/2"	3-Flat Car / Constr.
ASF-4064	5/8"	0.343	6-1/2"	4-1/2"	1/2"	3-Flat Car / Constr.
ASF-4464	11/16"	0.375	7"	4-1/2"	1/2"	3-Flat Car / Constr.
ASF-4864	3/4"	0.406	7-1/4"	5"	1/2"	3-Flat Car / Constr.
ASF-5264	13/16"	0.468	7-1/4"	5"	1/2"	3-Flat Car / Constr.
ASF-5664	7/8"	0.500	7-1/4"	5"	1/2"	3-Flat Car / Constr.
ASF-6064	15/16"	0.585	7-1/4"	5"	1/2"	3-Flat Car / Constr.
ASF-6464	1"	0.594	7-1/4"	5"	1/2"	3-Flat Car / Constr.
ASF-8064	1-1/4"	0.719	7-1/4"	5"	1/2"	3-Flat Car / Constr.

BLACK-GOLD



- ◆ M2 HSS
- ◆ Tapered Point
- ◆ Left-Hand Spiral
- ◆ Right-Hand Cut
- ◆ 3-Flat Shank
- ◆ Sold Individually



Reamer - CAR/Construction - Fast Spiral - M2 HSS

Part #	Size	Point Diameter	OAL	Flute	Shank	Type
AFC-2464	3/8"	0.250	5"	4"	3/8"	3-Flat Car / Constr.
AFC-3264	1/2"	0.281	6"	4-1/2"	1/2"	3-Flat Car / Constr.
AFC-3664	9/16"	0.343	6-1/4"	4-1/2"	1/2"	3-Flat Car / Constr.
AFC-4064	5/8"	0.343	6-1/2"	4-1/2"	1/2"	3-Flat Car / Constr.
AFC-4464	11/16"	0.375	7"	4-1/2"	1/2"	3-Flat Car / Constr.
AFC-4864	3/4"	0.406	7-1/4"	5"	1/2"	3-Flat Car / Constr.
AFC-5264	13/16"	0.468	7-1/4"	5"	1/2"	3-Flat Car / Constr.
AFC-5664	7/8"	0.500	7-1/4"	5"	1/2"	3-Flat Car / Constr.
AFC-6064	15/16"	0.585	7-1/4"	5"	1/2"	3-Flat Car / Constr.
AFC-6464	1"	0.594	7-1/4"	5"	1/2"	3-Flat Car / Constr.
AFC-8064	1-1/4"	0.719	7-1/4"	5"	1/2"	3-Flat Car / Constr.

BLACK-GOLD



- ◆ M2 HSS
- ◆ Tapered Point
- ◆ Left-Hand Spiral
- ◆ Right-Hand Cut
- ◆ 3-Flat Shank
- ◆ Sold Individually



Reamer - CAR - Spiral Flute - HEX - M2 HSS

Part #	Size	Point Diameter	OAL	Flute	Shank	Type
ACX-4464	11/16"	0.375	6-3/8"	4-1/2"	1-1/16"	HEX Car
ACX-5264	13/16"	0.468	7"	5"	1-1/4"	HEX Car
ACX-6064	15/16"	0.585	7"	5"	1-7/16"	HEX Car
ACX-6864	1-1/16"	0.807	7"	5"	1-5/8"	HEX Car

BLACK-GOLD



- ◆ M2 HSS
- ◆ Tapered Point
- ◆ Left-Hand Spiral
- ◆ Right-Hand Cut
- ◆ HEX Nut Shank
- ◆ Sold Individually





1" Cutting Depth



2" Cutting Depth

1" Annular Twist Drill-M2 HSS

2" Annular Twist Drill-M2 HSS



Part #	Size	Depth
100DR1664	1/4"	1"
100DR2064	5/16"	1"
100DR2464	3/8"	1"
100DR2864	7/16"	1"
100DR3264	1/2"	1"

Part #	Size	Depth
200DR1664	1/4"	2"
200DR2064	5/16"	2"
200DR2464	3/8"	2"
200DR2864	7/16"	2"
200DR3264	1/2"	2"

- ◆ M2 HSS
- ◆ 3/4" Weldon Shanks
- ◆ For Small Diameters
- ◆ Aggressive Cutting Edges
- ◆ No Center Punch Required
- ◆ Cut up to 2"
- ◆ For All Magnetic Drills
- ◆ Sold Individually

ANNULAR TWIST DRILL M2 HSS

SMALL MAG-DRILL DIAMETERS

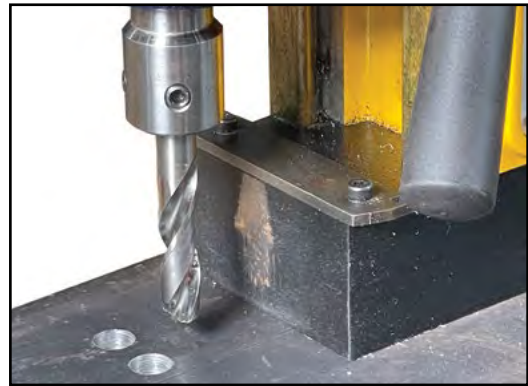

3/4" Weldon Shank

Use Cutting Oil



Annular Cutter Kit - 6 Pc.

Part #	Description
100MC-SET1	1" Cutting Depth
200MC-SET1	2" Cutting Depth

Each Set Include the Diameters: 1/2" • 9/16" • 5/8" • 3/4" • 13/16" • 7/8"

- ◆ M2 HSS
- ◆ 3/4" Weldon Shanks
- ◆ Aggressive Cutting Edges
- ◆ No Center Punch Required
- ◆ Cut up to 2"
- ◆ For All Magnetic Drills
- ◆ Sold Individually

ANNULAR CUTTER M2 HSS



3/4" Weldon Shank

Use Cutting Oil



6 H.S.S. Annular Cutters + 2 Pilot Pins



1" Cutting Depth



2" Cutting Depth



1" Annular Cutter - *M2 HSS*

Part #	Size	Depth	Pin
100MC2864	7/16"	1"	SS-1
100MC3264	1/2"	1"	SS-2
100MC3664	9/16"	1"	SS-3
100MC4064	5/8"	1"	SS-3
100MC4464	11/16"	1"	SS-3
100MC4864	3/4"	1"	SS-3
100MC5264	13/16"	1"	SS-3
100MC5664	7/8"	1"	SS-3
100MC6064	15/16"	1"	SS-3
100MC6464	1"	1"	SS-3
100MC6864	1-1/16"	1"	SS-3
100MC7264	1-1/8"	1"	SS-3
100MC7664	1-3/16"	1"	SS-3
100MC8064	1-1/4"	1"	SS-3
100MC8464	1-5/16"	1"	SS-3
100MC8864	1-3/8"	1"	SS-3
100MC9264	1-7/16"	1"	SS-3
100MC9664	1-1/2"	1"	SS-3
100MC1916	1-9/16"	1"	SS-3
100MC1058	1-5/8"	1"	SS-3
100MC1116	1-11/16"	1"	SS-3
100MC1034	1-3/4"	1"	SS-3
100MC1316	1-13/16"	1"	SS-3
100MC1078	1-7/8"	1"	SS-3
100MC1516	1-15/16"	1"	SS-3
100MC2002	2"	1"	SS-3
100MC2116	2-1/16"	1"	SS-3

2" Annular Cutter - *M2 HSS*

Part #	Size	Depth	Pin
200MC2864	7/16"	2"	LL-1
200MC3264	1/2"	2"	LL-2
200MC3664	9/16"	2"	LL-3
200MC4064	5/8"	2"	LL-3
200MC4464	11/16"	2"	LL-3
200MC4864	3/4"	2"	LL-3
200MC5264	13/16"	2"	LL-3
200MC5664	7/8"	2"	LL-3
200MC6064	15/16"	2"	LL-3
200MC6464	1"	2"	LL-3
200MC6864	1-1/16"	2"	LL-3
200MC7264	1-1/8"	2"	LL-3
200MC7664	1-3/16"	2"	LL-3
200MC8064	1-1/4"	2"	LL-3
200MC8464	1-5/16"	2"	LL-3
200MC8864	1-3/8"	2"	LL-3
200MC9264	1-7/16"	2"	LL-3
200MC9664	1-1/2"	2"	LL-3
200MC1916	1-9/16"	2"	LL-3
200MC1058	1-5/8"	2"	LL-3
200MC1116	1-11/16"	2"	LL-3
200MC1034	1-3/4"	2"	LL-3
200MC1316	1-13/16"	2"	LL-3
200MC1078	1-7/8"	2"	LL-3
200MC1516	1-15/16"	2"	LL-3
200MC2002	2"	2"	LL-3
200MC2116	2-1/16"	2"	LL-3



Steel



Stainless Cast Iron

- ◆ M2 HSS
- ◆ 3/4" Weldon Shanks
- ◆ Aggressive Cutting Edges
- ◆ No Center Punch Required
- ◆ Cut up to 2"
- ◆ For All Magnetic Drills
- ◆ Sold Individually



MAGNETIC DRILL



3/4" Weldon Shank

Use Cutting Oil



Allows overlap cut on existing holes

TCT - Carbide Tipped Annular Cutters Available. Please call.



Pilot Pins - 1" Cutter

Part #	Description
SS-1	1" Pilot Pin (for 7/16" x 1")
SS-2	1" Pilot Pin (for 1/2" x 1")
SS-3	1" Pilot Pin (for 9/16" x 1" +)



Pilot Pins - 2" Cutter

Part #	Description
LL-1	2" Pilot Pin (for 7/16" x 2")
LL-2	2" Pilot Pin (for 1/2" x 2")
LL-3	2" Pilot Pin (for 9/16" x 2" +)

ANNULAR CUTTER
M2 HSS



INTERNATIONAL TOOL MANUFACTURING
150 Express St. Plainview, NY 11803

(516) 738-0388 • (800) 247-5696

ITM® Fax (516) 279-1106

Made In



5/16", 3/8", 7/16", 1/2", 9/16"



9/16", 5/8", 11/16", 3/4", 13/16"



13/16", 7/8", 15/16", 1", 1-1/16"

Step Reamer - Individual - M2 HSS

Part #	Description	Depth	Qty.
STR-1	5 Step - 5/16" to 9/16"	1/2"	1
STR-2	5 Step - 9/16" to 13/16"	1/2"	1
STR-3	5 Step - 13/16" to 1-1/16"	1/2"	1



BLACK-GOLD

- ◆ M2 HSS
- ◆ 1/2" Cutting Depth
- ◆ Double Flute
- ◆ Black & Gold Coating
- ◆ 3/8" - 3-Flat Shank
- ◆ Sold Individually



Titanium Countersink - 3 FLUTE

Part #	Degree	Range	Qty.
SCS-82	82°	5/16" - 2-1/8"	1
SCS-90	90°	5/16" - 2-1/8"	1



**TITANIUM-M2 HSS
COUNTERSINK**

- ◆ Titanium Coating
- ◆ 3/4" Weldon Shanks
- ◆ Aggressive Cutting Edges
- ◆ For All Magnetic Drills
- ◆ Sold Individually

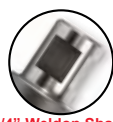

Use Cutting Oil



Step Reamer - 3 Pc. Kit - M2 HSS

Part #	Description	Depth	Qty.
STR-SET3	3 Pc. Kit with Case	1/2"	1

For Enlarging Holes in Steel Plate up to 1/2" Thick!



FEIN Adapter
Part # WFE-1



NITTO Adapter
Part # WNT-1



2" Extension
Part # MXT-2



6" Extension
Part # MXT-6

Mag Drill - Extensions & Adapters

Part #	Description	Ø
MXT-2	2" Weldon Mag Drill Extension	1-7/16"
MXT-3	3" Weldon Mag Drill Extension	1-7/16"
MXT-4	4" Weldon Mag Drill Extension	1-7/16"
MXT-6	6" Weldon Mag Drill Extension	1-7/16"
MXT-8	8" Weldon Mag Drill Extension	1-7/16"
MXT-10	10" Weldon Mag Drill Extension	1-7/16"
WFE-1	FEIN to Weldon Adapter	1-7/16"
WNT-1	NITTO to Weldon Adapter	1-7/16"

MAG DRILL ACCESSORIES
ARE SOLD INDIVIDUALLY.



MAGNETIC

MAGNETIC CHIP COLLECTOR

EASY CLEAN UP OF METAL CHIPS & SHAVINGS



1.



2.

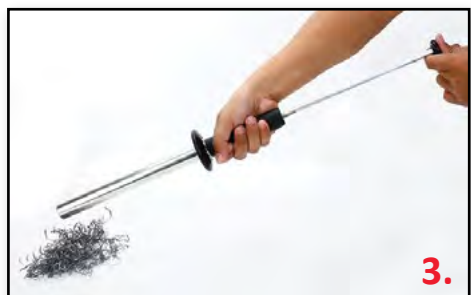

3.



Mag Drill 1/2" Chuck Adapter

Part #	Description
MAG-CHUCK	1/2" Chuck with Key

- ◆ Fits Any 3/4" Weldon Shank Mag Drill
- ◆ Use With 1/2" Shank Drill Accessories
- ◆ Sold Individually



Magnetic Chip Collector

Part #	Description
MAG-BAT	Magnetic Chip Collector

MAG DRILL ACCESSORIES ARE SOLD INDIVIDUALLY.



IMPACT
1/4" HEX IMPACT SHANK



Steel



Stainless



Sheet Metal



Copper

- ◆ Excellent Wear and Heat Resistance
- ◆ Tungsten Carbide Teeth
- ◆ Cuts Stainless Steel and Tough Alloys
- ◆ Ejects the Slug Saving Time
- ◆ Works in 3/8" & 1/2" Chucks
- ◆ Made In Taiwan



1/2" DRILL



IMPACT DRIVER

T.C.T. HOLE CUTTERS ARE SOLD INDIVIDUALLY.



3/16" Cutting Depth

T.C.T. Hole Cutter

Part #	Size	Depth	Shank
XF0012	5/8"	3/16"	1/4" HEX
XF0014	3/4"	3/16"	1/4" HEX
XF0016	7/8"	3/16"	1/4" HEX
XF0018	1"	3/16"	1/4" HEX
XF0019	1-1/8"	3/16"	1/4" HEX
XF0021	1-1/4"	3/16"	1/4" HEX
XF0023	1-3/8"	3/16"	1/4" HEX



3/16" Cutting Depth

T.C.T. Hole Cutter

Part #	Size	Depth	Shank
HF0012	5/8"	3/16"	3/8"
HF0013	11/16"	3/16"	3/8"
HF0014	3/4"	3/16"	3/8"
HF0015	13/16"	3/16"	3/8"
HF0016	7/8"	3/16"	3/8"
HF0017	15/16"	3/16"	3/8"
HF0018	1"	3/16"	3/8"
HF0119	1-1/16"	3/16"	3/8"
HF0019	1-1/8"	3/16"	3/8"
HF0021	1-1/4"	3/16"	3/8"
HF0023	1-3/8"	3/16"	3/8"
HF0024	1-1/2"	3/16"	3/8"
HF0025	1-5/8"	3/16"	3/8"
HF0026	1-3/4"	3/16"	3/8"
HF0027	1-7/8"	3/16"	3/8"
HF0028	2"	3/16"	3/8"
HF0029	2-1/8"	3/16"	3/8"
HF0030	2-1/4"	3/16"	3/8"
HF0032	2-3/8"	3/16"	3/8"
HF0033	2-1/2"	3/16"	1/2"
HF0135	2-3/4"	3/16"	1/2"
HF0035	3"	3/16"	1/2"
HF0138	3-1/4"	3/16"	1/2"
HF0036	3-1/2"	3/16"	1/2"
HF0140	3-5/8"	3/16"	1/2"
HF0037	4"	3/16"	1/2"

POW!

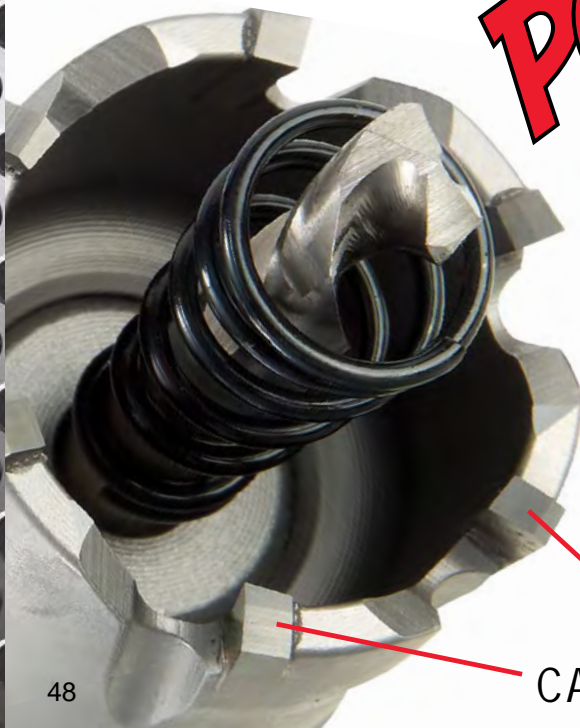

- Cut Faster
- Cut Cleaner
- Lasts Longer

TUNGSTEN CARBIDE TEETH



7/8" - 1-1/8" - 1-3/8"
1-3/4" - 2" - 2-1/2"

T.C.T. Hole Cutter Kits

Part #	Set	Depth	Shank
XF-KIT3	3 Pc.	3/16"	1/4" HEX
HF-KIT3	3 Pc.	3/16"	3/8"
HF-KIT6	6 Pc.	3/16"	3/8"

Size	Steel (rpm)	Stainless (rpm)
9/16" to 13/16"	700-1000	300-700
7/8" to 1-3/16"	500-800	200-450
1-1/4" to 1-9/16"	300-600	175-315
1-5/8" to 2"	200-500	120-225
2-1/16" to 2-3/8"	200-400	95-195
2-7/16" to 3"	150-300	80-150
3-1/16" to 5"	100-200	60-120



1/2" Cutting Depth

T.C.T. Hole Cutter

Part #	Size	Depth	Shank
HG0011	9/16"	1/2"	3/8"
HG0012	5/8"	1/2"	3/8"
HG0013	11/16"	1/2"	3/8"
HG0014	3/4"	1/2"	3/8"
HG0015	13/16"	1/2"	3/8"
HG0016	7/8"	1/2"	3/8"
HG0017	15/16"	1/2"	3/8"
HG0018	1"	1/2"	3/8"
HG0119	1-1/16"	1/2"	3/8"
HG0019	1-1/8"	1/2"	3/8"
HG0020	1-3/16"	1/2"	3/8"
HG0021	1-1/4"	1/2"	3/8"
HG0023	1-3/8"	1/2"	3/8"
HG0024	1-1/2"	1/2"	3/8"
HG0025	1-5/8"	1/2"	3/8"
HG0026	1-3/4"	1/2"	3/8"
HG0027	1-7/8"	1/2"	3/8"
HG0028	2"	1/2"	3/8"
HG0029	2-1/8"	1/2"	3/8"
HG0030	2-1/4"	1/2"	3/8"
HG0032	2-3/8"	1/2"	3/8"
HG0033	2-1/2"	1/2"	1/2"
HG0135	2-3/4"	1/2"	1/2"
HG0035	3"	1/2"	1/2"
HG0138	3-1/4"	1/2"	1/2"
HG0036	3-1/2"	1/2"	1/2"
HG0037*	4"	1/2"	1/2"
HG0040*	4-1/2"	1/2"	1/2"
HG0050*	5"	1/2"	1/2"

* Use Pilot Part# HG-PILOT2



Replacement Parts

Part #	Description
HF-PILOT	CENTER DRILL φ6mm x 50L
HF-S	SPRING 1.2MM X 16L
HG-PILOT	CENTER DRILL φ6mm x 60L
HG-PILOT2	CENTER DRILL φ8mm x 60L
HG-S	SPRING 1.2MM X 23L
HM-PILOT	CENTER DRILL φ6mm x 75L
HM-S	SPRING 1.2MM X 50L
HP-PILOT	CENTER DRILL φ6mm x 90L
HP-S	SPRING 1.2MM X 60L



1-3/8" Cutting Depth

T.C.T. Hole Cutter

Part #	Size	Depth	Shank
HM0011	9/16"	1-3/8"	1/2"
HM0012	5/8"	1-3/8"	1/2"
HM0013	11/16"	1-3/8"	1/2"
HM0014	3/4"	1-3/8"	1/2"
HM0015	13/16"	1-3/8"	1/2"
HM0016	7/8"	1-3/8"	1/2"
HM0017	15/16"	1-3/8"	1/2"
HM0018	1"	1-3/8"	1/2"
HM0119	1-1/16"	1-3/8"	1/2"
HM0019	1-1/8"	1-3/8"	1/2"
HM0020	1-3/16"	1-3/8"	1/2"
HM0021	1-1/4"	1-3/8"	1/2"
HM0023	1-3/8"	1-3/8"	1/2"
HM0024	1-1/2"	1-3/8"	1/2"
HM0025	1-5/8"	1-3/8"	1/2"
HM0026	1-3/4"	1-3/8"	1/2"
HM0027	1-7/8"	1-3/8"	1/2"
HM0028	2"	1-3/8"	1/2"
HM0029	2-1/8"	1-3/8"	1/2"
HM0030	2-1/4"	1-3/8"	1/2"
HM0032	2-3/8"	1-3/8"	1/2"
HM0033	2-1/2"	1-3/8"	1/2"



- ◆ Excellent Wear and Heat Resistance
- ◆ Tungsten Carbide Teeth
- ◆ Cuts Stainless Steel and Tough Alloys
- ◆ Works in 1/2" Chucks
- ◆ Made In Taiwan



T.C.T. HOLE CUTTERS ARE SOLD INDIVIDUALLY.



2" Cutting Depth

T.C.T. Steel Door Hole Cutter

Part #	Size	Cut	Shank
HP0014	3/4"	2"	1/2"
HP0018	1"	2"	1/2"
HP0021	1-1/4"	2"	1/2"
HP0029	2-1/8"	2"	1/2"

- ◆ Made for Door Knob and Lock Installation
- ◆ Tungsten Carbide Teeth
- ◆ Works in 1/2" Chucks
- ◆ Made In Taiwan

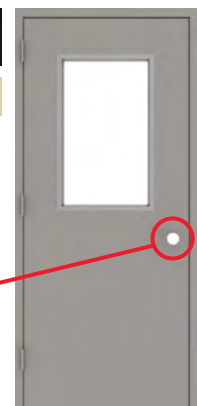



1 HOLE SAW PER BOX.
ARBOR NOT INCLUDED.

Made In



- ◆ Made In USA
- ◆ Tungsten Carbide Teeth
- ◆ Ground & Welded Set Teeth
- ◆ 3 Teeth Per Inch
- ◆ High Wear Resistance
- ◆ 1-15/16" Cutting Depth
- ◆ Premium Quality
- ◆ Black Finish



Carbide Tipped Hole Saws

Part #	Dia. Inches	Dia. MM	PIPE TAP SIZE		PIPE ENT. SIZE		Use Arbor
			Inches	MM	Inches	MM	
AT120034	3/4"	19.0	1/2"	13 mm	3/8"	10 mm	*
AT131316	13/16"	20.6					*
AT140078	7/8"	22.2	3/4"	19 mm	1/2"	13 mm	*
AT151516	15/16"	23.8					*
AT160001	1"	25.4					*
AT171116	1-1/16"	27.0					*
AT180118	1-1/8"	28.8	1"	25 mm	3/4"	19 mm	*
AT191316	1-3/16"	30.2					*
AT200114	1-1/4"	31.8			1"	25 mm	**
AT220138	1-3/8"	34.9					**
AT240112	1-1/2"	38.1	1-1/4"	32 mm			**
AT260158	1-5/8"	41.2					**
AT280134	1-3/4"	44.5	1-1/2"	38 mm	1-1/4"	32 mm	**
AT300178	1-7/8"	47.6					**
AT320002	2"	50.8			1-1/2"	38 mm	**
AT340218	2-1/8"	53.9					**
AT360214	2-1/4"	57.2	2"	51 mm			**
AT380238	2-3/8"	60.3					**
AT400212	2-1/2"	63.5			2"	51 mm	**
AT412916	2-9/16"	65.1					**
AT420258	2-5/8"	66.7	2-1/2"	64 mm			**
AT440234	2-3/4"	69.9					**
AT460278	2-7/8"	73.0					**
AT480003	3"	76.2			2-1/2"	64 mm	**
AT500318	3-1/8"	79.4					**
AT520314	3-1/4"	82.6	3"	76 mm			**
AT540338	3-3/8"	85.7					**
AT560312	3-1/2"	88.9					**
AT580358	3-5/8"	92.1			3"	76 mm	**
AT600334	3-3/4"	95.3	3-1/2"	89 mm			**
AT620378	3-7/8"	98.4					**
AT640004	4"	101.6					**
AT660418	4-1/8"	104.8					**
AT680414	4-1/4"	108.0	4"	102 mm	3-1/2"	89 mm	**
AT700438	4-3/8"	111.0					**
AT720412	4-1/2"	114.3			4"	102 mm	**
AT760434	4-3/4"	120.7					**
AT800005	5"	127.0					**
AT880512	5-1/2"	139.7					**
AT920534	5-3/4"	146.0					**
AT960006	6"	152.4					**

These High Quality Carbide Tipped Hole Saws have the highest wear resistance for abrasive materials. They are ideal for work where high performance & accuracy are needed. Saws have knock-out holes for easy core removal.

* ARB-0, ARB-1 or ARB-2 with (1/2"-20 Thread).
** ARB-3, ARB-4 or ARB-5 with (5/8"-18 Thread).

CARBIDE TIPPED RPM CHART

SIZE	ALUMINUM	PLASTIC	FIBER-GLASS	CERAMIC TILE	PARTICLE BOARD	CAST IRON	FORMICA
3/4"	1700	3430	250	500	3430	410	210
7/8"	1500	2940	210	430	2940	350	180
1"	1300	2570	190	370	2570	310	150
1-1/8"	1100	2290	170	330	2290	270	140
1-3/8"	900	1870	140	270	1870	220	110
1-1/2"	900	1710	120	250	1710	210	100
1-3/4"	700	1470	110	210	1470	180	90
2"	600	1290	90	190	1290	150	80
2-1/4"	600	1140	80	170	1140	140	70
2-1/2"	500	1030	70	150	1030	120	60
3"	400	860	60	120	860	100	50
3-1/4"	400	790	60	110	790	90	50
3-5/8"	400	710	50	100	710	90	40
3-3/4"	300	690	50	100	690	80	40
4-1/8"	300	620	50	90	620	70	40
4-3/4"	300	540	40	80	540	60	30
5"	200	480	40	80	500	60	30
5-1/2"	200	420	40	70	460	50	30
6"	100	360	30	60	420	40	30



Bi-Metal Hole Saws - Variable Pitch

Part #	Dia.	Dia.	PIPE TAP SIZE		PIPE ENT. SIZE		Use Arbor
	Inches	MM	Inches	MM	Inches	MM	
275HW0011	9/16"	14.3	3/8"				*
275HW0012	5/8"	15.5					*
275HW0013	11/16"	17.5					*
275HW0014	3/4"	19.0	1/2"	13 mm	3/8"	10 mm	*
275HW0114	20mm	20.0					*
275HW0015	13/16"	20.6					*
275HW0016	7/8"	22.2	3/4"	19 mm	1/2"	13 mm	*
275HW0017	15/16"	23.8					*
275HW0018	1"	25.4					*
275HW0185	1-1/16"	27.0					*
275HW0019	1-1/8"	28.8	1"	25 mm	3/4"	19 mm	*
275HW0020	1-3/16"	30.2					*
275HW0021	1-1/4"	31.8					**
275HW0023	1-3/8"	34.9			1"	25 mm	**
275HW0123	1-7/16"	36.5					**
275HW0024	1-1/2"	38.1	1-1/4"	32 mm			**
275HW0124	1-9/16"	39.7					**
275HW0025	1-5/8"	41.2					**
275HW0125	1-11/16"	42.9					**
275HW0026	1-3/4"	44.5	1-1/2"	38 mm	1-1/4"	32 mm	**
275HW0226	45mm	45.0					**
275HW0126	1-13/16"	46.0					**
275HW0027	1-7/8"	47.6					**
275HW0127	50mm	50.0					**
275HW0028	2"	50.8			1-1/2"	38 mm	**
275HW0128	2-1/16"	52.4					**
275HW0029	2-1/8"	53.9					**
275HW0030	2-1/4"	57.2	2"	51 mm			**
275HW0031	2-5/16"	58.7					**
275HW0032	2-3/8"	60.3					**
275HW0033	2-1/2"	63.5			2"	51 mm	**
275HW0034	2-9/16"	65.1					**
275HW0134	2-5/8"	66.7	2-1/2"	64 mm			**
275HW0234	68mm	68.0					**
275HW0334	68.5mm	68.5					**
275HW0135	2-3/4"	69.9					**
275HW0136	2-7/8"	73.0					**
275HW0236	75mm	75.0					**
275HW0035	3"	76.2			2-1/2"	64 mm	**
275HW0137	3-1/8"	79.4					**
275HW0138	3-1/4"	82.6	3"	76 mm			**
275HW0139	3-3/8"	85.7					**
275HW0036	3-1/2"	88.9					**
275HW0140	3-5/8"	92.1			3"	76 mm	**
275HW0141	3-3/4"	95.3	3-1/2"	89 mm			**
275HW0142	3-7/8"	98.4					**
275HW0100	100mm	100.0					**
275HW0037	4"	101.6					**
275HW0143	4-1/8"	104.8			3-1/2"	89 mm	**
275HW0144	4-1/4"	108.0	4"	102 mm			**
275HW0038	4-1/2"	114.3			4"	102 mm	**
275HW0145	4-3/4"	120.7	4-1/2"				**
275HW0039	5"	127.0					**
275HW0040	5-1/2"	139.7					**
275HW0146	5-3/4"	146.0					**
275HW0041	6"	152.4					**



1 HOLE SAW PER BOX.
ARBOR NOT INCLUDED.

Made In



- ◆ Made In USA
- ◆ Bi-Metal Construction
- ◆ M3 Cutting Edge
- ◆ 5 Variable Pitch. Rc. 63-65
- ◆ Positive Rake
- ◆ 1-15/16" Cutting Depth
- ◆ Premium Quality
- ◆ Cuts Through a 2" x 4"
- ◆ Red Finish



* ARB-0, ARB-1 or ARB-2 with (1/2"-20 Thread).
** ARB-3, ARB-4 or ARB-5 with (5/8"-18 Thread).

These High Quality Bi-Metal Hole Saws are made by a very special process. The cutting edge is electron beam welded to a tough alloy steel back. These hole saws are ideal for work where high performance & accuracy are needed. Saws have knock-out holes for easy core removal.



- ◆ Made In USA
- ◆ Bi-Metal Construction
- ◆ M3 Cutting Edge
- ◆ Positive Rake
- ◆ 1-15/16" Cutting Depth
- ◆ Cuts Through a 2" x 4"

Made In



BI-METAL



BI-METAL



BI-METAL

PART # 275AV02E
ELECTRICIAN'S HOLE SAW KIT

8 Pc. Set contains:
1 each 7/8" - 1-1/8" - 1-3/8" - 1-3/4" - 2" - 2-1/2"
2 Arbors - ARB-2 - ARB-5

PART # 275AV08E
MASTER ELECTRICIAN'S HOLE SAW KIT

12 Pc. Set contains:
1 each 7/8" - 1-1/8" - 1-3/8" - 1-3/4" - 2" - 2-1/2"
3" - 3-5/8" - 4-1/8" - 4-1/2"
2 Arbors - ARB-2 - ARB-5

PART # 275AV04P
PLUMBER'S HOLE SAW KIT

8 Pc. Set contains:
1 each 3/4" - 7/8" - 1-1/8" - 1-1/2" - 1-3/4" - 2-1/4"
2 Arbors - ARB-2 - ARB-5



BI-METAL



CARBIDE TIPPED

PART # 275AV100
MAINTENANCE HOLE SAW KIT

11 Pc. Set contains:
1 each 3/4" - 7/8" - 1-1/8" - 1-3/8" - 1-1/2"
1-3/4" - 2" - 2-1/4" - 2-1/2"
2 Arbors - ARB-2 - ARB-5

PART # 275AT100
CARBIDE TIPPED MAINTENANCE HOLE SAW KIT

11 Pc. Set contains:
1 each 3/4" - 7/8" - 1-1/8" - 1-3/8" - 1-1/2"
1-3/4" - 2" - 2-1/4" - 2-1/2"
2 Arbors - ARB-2 - ARB-5

Arbor Adapter

PART #
NUT001

Adapter Nut



Turns
1/2"-20
Thread
To 5/8"-18
Thread

Use With Arbors ARB-0, ARB-1,
ARB-2 to Fit Hole Saws
Larger Than 1-1/4".

- ◆ 3/8" or 7/16" Hex Shank
- ◆ 1 Set Screw
- ◆ Sold Individually



1/2" DRILL



7/8"



3/4"

12" Hole Saw Extensions

Part #	Size	For Shank	Ø
EXT001	7/16" x 12"	7/16"	7/8"
EXT002	3/8" x 12"	3/8"	3/4"

Hole Saw Extensions - Pass Thru Hole
Drill Diameter Must Be Larger Than 3/4" or 7/8".



INDIVIDUALLY BOXED AND SOLD IN A 5 PACK.

FOR USE WITH:

- Bi-Metal Hole Saws
- Carbide Tipped Hole Saws



- ◆ Industrial Quality
- ◆ Individually Boxed & Sold in a 5 Pack
- ◆ Includes (1) 1-Flat 1/4" HSS Pilot Drill



Arbors - With 1/4" Pilot Drill - M2 HSS

<p>PART # ARB-0 1/4" 3-FLAT SHANK ARBOR FOR HOLE SAWS 9/16" - 1-3/16"</p>	<p>HSS PILOT 277PD0018 1/2"-20 Thread</p>
<p>PART # ARB-1 1/4" HEX POWER SHANK ARBOR FOR HOLE SAWS 9/16" - 1-3/16"</p>	<p>HSS PILOT 277PD0018 1/2"-20 Thread</p>
<p>PART # ARB-2 3/8" HEX POWER SHANK ARBOR FOR HOLE SAWS 9/16" - 1-3/16"</p>	<p>HSS PILOT 277PD0018 1/2"-20 Thread</p>
<p>PART # ARB-3 1/4" HEX POWER SHANK ARBOR FOR HOLE SAWS 1-1/4" - 6"</p>	<p>HSS PILOT 277PD0018 5/8"-18 Thread</p>
<p>PART # ARB-4 3/8" HEX POWER SHANK ARBOR FOR HOLE SAWS 1-1/4" - 6"</p>	<p>HSS PILOT 277PD0018 5/8"-18 Thread</p>
<p>PART # ARB-5 7/16" HEX POWER SHANK ARBOR FOR HOLE SAWS 1-1/4" - 6"</p>	<p>HSS PILOT 277PD0018 5/8"-18 Thread</p>

1/4" Pilot Drills - M2 HSS



SOLD IN AN ENVELOPE OF 10.

- ◆ Industrial Quality
- ◆ High Speed Steel
- ◆ Designed For Arbors

<p>PART # 277PD0014 1/4" HSS PILOT DRILL 3 STEPS 4" OAL</p>	
<p>PART # 277PD0016 1/4" HSS PILOT DRILL 3 FLATS 4" OAL FOR USE WITH ARB-0!</p>	
<p>PART # 277PD0018 1/4" HSS PILOT DRILL 1 FLAT 3-1/8" OAL FOR USE WITH ARB-1, ARB-2, ARB-3, ARB-4, AND ARB-5!</p>	



- ◆ Made In USA
- ◆ Carbide Teeth
- ◆ Thin Kerf
- ◆ Sold Individually in a Blister or Box of 10



5-3/8" Circular Saw Blade - Steel

Part #	Size	Teeth	Arbor	RPM	QTY.
102513	5-3/8"	32T	5/8"-20mm -10mm	4200	1
102940	5-3/8"	32T	5/8"-20mm -10mm	4200	10/box



- ◆ Made In USA
- ◆ Carbide Teeth
- ◆ Thin Kerf
- ◆ Sold Individually in a Blister or Box of 10



7-1/4" Circular Saw Blade - Steel

Part #	Size	Teeth	Arbor	RPM	QTY.
102636	7-1/4"	48T	5/8" - K.O.	5800	1
102971	7-1/4"	48T	5/8" - K.O.	5800	10/box
102643	7-1/4"	48T	20mm	5800	1



- ◆ Made In USA
- ◆ Carbide Teeth
- ◆ Thin Kerf
- ◆ Sold Individually



7-1/4" Circular Saw Blade - Aluminum

Part #	Size	Teeth	Arbor	RPM	QTY.
102650	7-1/4"	56T	5/8" - K.O.	5800	1
102667	7-1/4"	56T	20mm	5800	1



- ◆ Made In USA
- ◆ Carbide Teeth
- ◆ Thin Kerf
- ◆ Sold Individually



7-1/4" Circular Saw Blade - Stainless

Part #	Size	Teeth	Arbor	RPM	QTY.
102698	7-1/4"	56T	20mm	5800	1



- ◆ Made In USA
- ◆ Carbide Teeth
- ◆ Thin Kerf
- ◆ Sold Individually



8" Circular Saw Blade - Steel

Part #	Size	Teeth	Arbor	RPM	QTY.
102704	8"	48T	5/8" - K.O.	5800	1



10" Circular Saw Blade - Thin Steel

Part #	Size	Teeth	Arbor	RPM	QTY.
102766	10"	52T	5/8"	5200	1

- ◆ Made In USA
- ◆ Carbide Teeth
- ◆ Thin Kerf
- ◆ Sold Individually



10" Circular Saw Blade - Aluminum

Part #	Size	Teeth	Arbor	RPM	QTY.
102773	10"	72T	5/8"	5200	1

- ◆ Made In USA
- ◆ Carbide Teeth
- ◆ Thin Kerf
- ◆ Sold Individually



12" Circular Saw Blade - Steel

Part #	Size	Teeth	Arbor	RPM	QTY.
102797	12"	60T	1"	1800	1

- ◆ Made In USA
- ◆ Carbide Teeth
- ◆ Thin Kerf
- ◆ Sold Individually

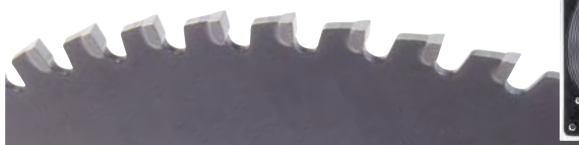

14" Circular Saw Blade - Steel

Part #	Size	Teeth	Arbor	RPM	QTY.
102841	14"	66T	1"	1800	1

- ◆ Made In USA
- ◆ Carbide Teeth
- ◆ Thin Kerf
- ◆ Low RPM Chop Saws
- ◆ Sold Individually

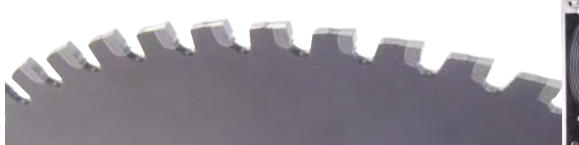

14" Circular Saw Blade - Stainless

Part #	Size	Teeth	Arbor	RPM	QTY.
102889	14"	90T	1"	1800	1

- ◆ Made In USA
- ◆ Carbide Teeth
- ◆ Thin Kerf
- ◆ Low RPM Chop Saws
- ◆ Sold Individually





INTERNATIONAL TOOL MANUFACTURING
150 Express St. Plainview, NY 11803

(516) 738-0388 • (800) 247-5696

ITM Fax (516) 279-1106



FACTORY BULK



NEW!



- ◆ Made In USA
- ◆ Bi-Metal
- ◆ 8% Cobalt
- ◆ Premium Quality
- ◆ Standard or Variable Pitch



SOLD 3 BLADES PER BOX.

27-3/16" Band Saw Blades - Bi-Metal

Part #	OAL	Teeth Per Inch	Wide	Thick	QTY.
B270018	27-3/16"	18T	1/2"	.020"	3
B271418	27-3/16"	14/18T	1/2"	.020"	3

DEWALT® - DCS375B & DCS377B
MILWAUKEE® - 2429-21XC

28-13/16" Band Saw Blades - Bi-Metal

Part #	OAL	Teeth Per Inch	Wide	Thick	QTY.
B280018	28-13/16"	18T	1/2"	.020"	3
B281418	28-13/16"	14/18T	1/2"	.020"	3

BOSCH® - BSH180, GCB18V-2N
MAKITA® - XBP05ZB

30-9/16" Band Saw Blades - Bi-Metal

Part #	OAL	Teeth Per Inch	Wide	Thick	QTY.
B300018	30-9/16"	18T	1/2"	.020"	3
B301418	30-9/16"	14/18T	1/2"	.020"	3

MILWAUKEE® - 2529-20, 2529-XC

32-7/8" Band Saw Blades - Bi-Metal

Part #	OAL	Teeth Per Inch	Wide	Thick	QTY.
B320018	32-7/8"	18T	1/2"	.020"	3
B321418	32-7/8"	14/18T	1/2"	.020"	3

DEWALT® - DCS370L, DCS370B, DCS370K, DCS371B
MAKITA® - XBP03Z, XBP04Z

35-3/8" Band Saw Blades - Bi-Metal

Part #	OAL	Teeth Per Inch	Wide	Thick	QTY.
B350018	35-3/8"	18T	1/2"	.020"	3
B351418	35-3/8"	14/18T	1/2"	.020"	3

MILWAUKEE® - 2629-20, 2629-22, 6242-6

44-7/8" Band Saw Blades - Bi-Metal

Part #	OAL	Teeth Per Inch	Wide	Thick	QTY.
279SB0014	44-7/8"	14T	1/2"	.020"	3
279SB0018	44-7/8"	18T	1/2"	.020"	3
279SB0024	44-7/8"	24T	1/2"	.020"	3
279VP1014	44-7/8"	10/14	1/2"	.020"	3
279VP1418	44-7/8"	14/18	1/2"	.020"	3

COMPATIBLE WITH A NUMBER OF LEADING PORTABLE BAND SAW MACHINES.



Made In



All Purpose Reciprocating Blades - **Wood Cutting** - Bi-Metal

Part #	Blade Length	Teeth Per Inch	Description	Width / Length	Pack QTY.	Bulk (50 Pcs.) Part #
RB636W	6"	6T	Wood & Nail Slope	3/4" x 6" x .050"	5	BU-RB636W
RB956W	9"	6T	Wood & Nail	3/4" x 9" x .050"	5	BU-RB956W
RB125W	12"	6T	Wood & Nail	3/4" x 12" x .050"	5	BU-RB125W
RB636DW	6"	6T	Drywall - V Tooth	3/4" x 6" x .050"	5	BU-RB636DW



- ◆ Made In USA
- ◆ 1/2" Universal Shank
- ◆ Bi-Metal
- ◆ 8% Cobalt
- ◆ Tooth Hardness Rc 65-67



Made In



All Purpose Reciprocating Blades - **Metal Cutting** - Bi-Metal

Part #	Blade Length	Teeth Per Inch	Description	Width / Length	Pack QTY.	Bulk (50 Pcs.) Part #
RB414M	4"	14T	Metal	3/4" x 4" x .035"	5	BU-RB414M
RB418M	4"	18T	Metal	3/4" x 4" x .035"	5	BU-RB418M
RB424M	4"	24T	Metal	3/4" x 4" x .035"	5	BU-RB424M
RB610HDM	6"	10T	Metal	3/4" x 6" x .035"	5	BU-RB610HDM
RB614HDM	6"	14T	Metal	3/4" x 6" x .035"	5	BU-RB614HDM
RB618HDM	6"	18T	Metal	3/4" x 6" x .035"	5	BU-RB618HDM
RB624HDM	6"	24T	Metal	3/4" x 6" x .035"	5	BU-RB624HDM
RB810HDM	8"	10T	Metal 10/14 V.P.	3/4" x 8" x .035"	5	BU-RB810HDM
RB814HDM	8"	14T	Metal	3/4" x 8" x .035"	5	BU-RB814HDM
RB818HDM	8"	18T	Metal	3/4" x 8" x .035"	5	BU-RB818HDM
RB1010HDM	10"	10T	Metal	3/4" x 10" x .035"	5	BU-RB1010HDM
RB1018HDM	10"	18T	Metal	3/4" x 10" x .035"	5	BU-RB1018HDM
RB1218HDM	12"	18T	Metal	3/4" x 12" x .035"	5	BU-RB1218HDM
R8CCRF	8"	CARBIDE GRIT	Cast Iron Ceramics	3/4" x 8" x .050"	1	BU-R8CCRF



Wood - Metal Sleeve of 5. Box of 50.





INTERNATIONAL TOOL MANUFACTURING
150 Express St. Plainview, NY 11803

(516) 738-0388 • (800) 247-5696

ITM® Fax (516) 279-1106

Made In

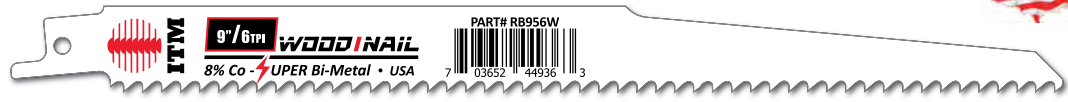

All Purpose Reciprocating Blades - Wood Cutting - Bi-Metal

Part #	Blade Length	Teeth Per Inch	Description	Width / Length	Pack QTY.	Part # QTY. 50 Pcs.
W636	6"	6T	Wood & Nail Slope	3/4" x 6" x .050"	5	W636-B
W956	9"	6T	Wood & Nail	3/4" x 9" x .050"	5	W956-B
W125	12"	6T	Wood & Nail	3/4" x 12" x .050"	5	W125-B
DW636	6"	6T	Drywall - V Tooth	3/4" x 6" x .050"	5	DW636-B



Wood/Nail Wood Fiberboard

- ◆ 1/2" Universal Shank
- ◆ Bi-Metal
- ◆ 8% Cobalt
- ◆ Tooth Hardness Rc 65-67



Made In



All Purpose Reciprocating Blades - Metal Cutting - Bi-Metal

Part #	Blade Length	Teeth Per Inch	Description	Width / Length	Pack QTY.	Part # QTY. 50 Pcs.
M414	4"	14T	Metal	3/4" x 4" x .035"	5	M414-B
M418	4"	18T	Metal	3/4" x 4" x .035"	5	M418-B
M424	4"	24T	Metal	3/4" x 4" x .035"	5	M424-B
M610	6"	10T	Metal	3/4" x 6" x .035"	5	M610-B
M614	6"	14T	Metal	3/4" x 6" x .035"	5	M614-B
M618	6"	18T	Metal	3/4" x 6" x .035"	5	M618-B
M624	6"	24T	Metal	3/4" x 6" x .035"	5	M624-B
M810	8"	10T	Metal 10/14 V.P.	3/4" x 8" x .035"	5	M810-B
M814	8"	14T	Metal	3/4" x 8" x .035"	5	M814-B
M818	8"	18T	Metal	3/4" x 8" x .035"	5	M818-B
M1010	10"	10T	Metal	3/4" x 10" x .035"	5	M1010-B
M1018	10"	18T	Metal	3/4" x 10" x .035"	5	M1018-B
M1218	12"	18T	Metal	3/4" x 12" x .035"	5	M1218-B



Steel Aluminum Sheet Metal Mild Stainless

- ◆ Made In USA
- ◆ 1/2" Universal Shank
- ◆ Bi-Metal
- ◆ 8% Cobalt
- ◆ Tooth Hardness Rc 65-67

Made In



HEAVY METAL Reciprocating Blades - Bi-Metal

Part #	Blade Length	Teeth Per Inch	Description	Width / Length	Pack QTY.	Part # QTY. 50 Pcs.
HM610	6"	10T	Heavy Metal	1" x 6" x .042"	5	HM610-B
HM614	6"	14T	Heavy Metal	1" x 6" x .042"	5	HM614-B
HM618	6"	18T	Heavy Metal	1" x 6" x .042"	5	HM618-B
HM910	9"	10T	Heavy Metal	1" x 9" x .042"	5	HM910-B
HM914	9"	14T	Heavy Metal	1" x 9" x .042"	5	HM914-B
HM918	9"	18T	Heavy Metal	1" x 9" x .042"	5	HM918-B
HM1214	12"	14T	Heavy Metal	1" x 12" x .042"	5	HM1214-B
HM1218	12"	18T	Heavy Metal	1" x 12" x .042"	5	HM1218-B



- ◆ Made In USA
- ◆ 1/2" Universal Shank
- ◆ Bi-Metal
- ◆ 8% Cobalt
- ◆ Tooth Hardness Rc 65-67

Made In



MAX METAL Carbide Tipped Reciprocating Blades

Part #	Blade Length	Teeth Per Inch	Description	Width / Length	Pack QTY.	List/Pack	Part # QTY. 25 Pcs.	List/Pack
CT6	6"	8T	Carbide Teeth	1" x 6" x .050"	5		CT6-B	
CT9	9"	8T	Carbide Teeth	1" x 9" x .050"	5		CT9-B	
CT12	12"	8T	Carbide Teeth	1" x 12" x .050"	5		CT12-B	



**CUT FASTER.
CUT LONGER.** 59



INTERNATIONAL TOOL MANUFACTURING

150 Express St. Plainview, NY 11803

(516) 738-0388 • (800) 247-5696

ITM® Fax (516) 279-1106

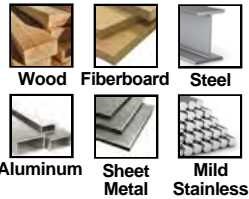

- ◆ **Made In USA**
- ◆ 1/2" Universal Shank
- ◆ Bi-Metal
- ◆ 8% Cobalt
- ◆ Tooth Hardness Rc 65-67
- ◆ 45% Thicker Than All Purpose Blades
- ◆ Stay Rigid
- ◆ No Vibration



THE LONGEST RECIPROCATING BLADE ON THE MARKET. GREAT FOR LARGE PIPE WHERE A 12" LONG BLADE WILL NOT WORK.



Made In



VIGOR™ Heavy Duty Reciprocating Blades - Bi-Metal

Part #	Blade Length	Teeth Per Inch	Description	Width / Length	Pack QTY.	Part # QTY. 50 Pcs.
HD610	6"	10/14 VP	Heavy Duty	3/4" x 6" x .050"	5	HD610-B
HD810	8"	10/14 VP	Heavy Duty	3/4" x 8" x .050"	5	HD810-B
HD120	12"	10/14 VP	Heavy Duty	3/4" x 12" x .050"	5	HD120-B

VP = Variable Pitch Teeth



Made In



VIGOR™ Demolition Reciprocating Blades - Bi-Metal

Part #	Blade Length	Teeth Per Inch	Description	Width / Length	Pack QTY.	Part # QTY. 25 Pcs.
DM606	6"	6T	Demolition	7/8" x 6" x .062"	3	DM606-B
DM610	6"	10T	Demolition	7/8" x 6" x .062"	3	DM610-B
DM906	9"	6T	Demolition	7/8" x 9" x .062"	3	DM906-B
DM910	9"	10T	Demolition	7/8" x 9" x .062"	3	DM910-B
DM1206	12"	6T	Demolition	7/8" x 12" x .062"	3	DM1206-B
DM1210	12"	10T	Demolition	7/8" x 12" x .062"	3	DM1210-B



- ◆ 1/2" Universal Shank
- ◆ Bi-Metal
- ◆ 8% Cobalt
- ◆ Tooth Hardness Rc 65-67





High Tension Hack Saw Frame

Part #	Description
278HX0002	High Tension Hack Saw Frame



- ◆ Made In USA
- ◆ Bi-Metal
- ◆ 8% Cobalt
- ◆ Premium Quality
- ◆ White Finish

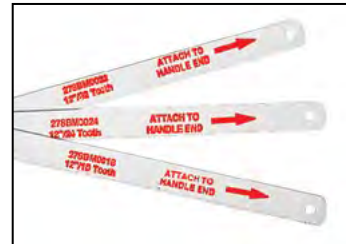

Hack Saw Blades - Bi-Metal

Part #	OAL	Teeth Per Inch	Wide	Thick	QTY.
278BM0018	12"	18T	1/2"	.025"	10
278BM0024	12"	24T	1/2"	.025"	10



18" x 6T DEMO DECAPITATOR



DECAPITATOR Demolition Reciprocating Blades - Bi-Metal

Part #	Blade Length	Teeth Per Inch	Description	Width / Length	Pack QTY.	Part # QTY. 25 Pcs.
CDM186	18"	6T	Demolition	7/8" x 18" x .062"	3	CDM186-B



- ◆ Bi-Metal
- ◆ 8% Cobalt
- ◆ Deep Plunge Depth
- ◆ Premium Quality



Retail (1)



Bulk (5)



Bulk (10)



Oscillating Blades - Wood / Plastic

	Part #	Teeth	Width	Plunge	Qty.
	OW-2	BIM-Japanese	1-3/8"	1-1/2"	1
	OW-2A	BIM-Japanese	1-3/8"	1-1/2"	5
	OW-2B	BIM-Japanese	1-3/8"	1-1/2"	10
	OW-3	BIM-Japanese	1-3/4"	2-1/4"	1
	OW-3A	BIM-Japanese	1-3/4"	2-1/4"	5
	OW-3B	BIM-Japanese	1-3/4"	2-1/4"	10

Oscillating Blades - Metal / Wood & Nail

	Part #	Teeth	Width	Plunge	Qty.
	OM-2	BIM-Titanium	1-3/8"	1-1/2"	1
	OM-2A	BIM-Titanium	1-3/8"	1-1/2"	5
	OM-2B	BIM-Titanium	1-3/8"	1-1/2"	10
	OM-3	BIM-Titanium	1-3/4"	2-1/4"	1
	OM-3A	BIM-Titanium	1-3/4"	2-1/4"	5
	OM-3B	BIM-Titanium	1-3/4"	2-1/4"	10

Oscillating Blades - Max Metal Carbide Tipped - Stainless / Hard Metal

	Part #	Teeth	Width	Plunge	Qty.
	OCS-2	Carbide	1-3/8"	1-1/2"	1
	OCS-2A	Carbide	1-3/8"	1-1/2"	5
	OCS-2B	Carbide	1-3/8"	1-1/2"	10

Oscillating Blades - Scrapers - Linoleum / Adhesive / Paint / Sealants

	Part #	Teeth	Width	Plunge	Qty.
	ORB-1	Stainless/Rigid	2"	1-1/2"	1
	ORB-1A	Stainless/Rigid	2"	1-1/2"	5
	ORB-1B	Stainless/Rigid	2"	1-1/2"	10
	OFB-1	Stainless/Flex	2"	1-1/2"	1
	OFB-1A	Stainless/Flex	2"	1-1/2"	5
	OFB-1B	Stainless/Flex	2"	1-1/2"	10
	OSG-2	Stainless/Caulk	2"	3"	1
	OSG-2A	Stainless/Caulk	2"	3"	5
	OSG-2B	Stainless/Caulk	2"	3"	10

Oscillating Blades - Drywall / Grout

	Part #	Teeth	Width	Plunge	Qty.
	WDR-3	BIM-Drywall	3-1/2"	3/4"	1
	OCG-2	Carbide-Grout	3-1/2"	3/4"	1

OSCILLATING BLADES

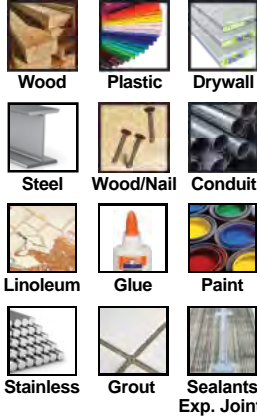

- ◆ Open Fit / Quick Release
- ◆ Bi-Metal
- ◆ Deep Plunge Depth
- ◆ Premium Quality



Open Fit / Quick Release



Wood

Bi-Metal



Stainless
Carbide Titanium Coated



Metal

Bi-Metal Titanium Coated



Flexible



Rigid

Sealants / Exp. Joints

Scrapers



Drywall

Bi-Metal



Grout

Carbide Grit

Part #	Size	Qty.
--------	------	------

OM-2	1-3/8" X 1-1/2" (METAL)	10
OM-3	1-3/4" X 2-1/4" (METAL)	10
OW-2	1-3/8" X 1-1/2" (WOOD)	10
OW-3	1-3/4" X 2-1/4" (WOOD)	10
OCS-2	1-3/8" X 1-1/2" (CARBIDE)	10
ORB-1	2" X 1" (RIGID SCRAPER)	10
OFB-1	2" X 1" (FLEX SCRAPER)	10
WDR-3	3-1/2" CIRCLE (DRYWALL)	10
OCG-2	3-1/2" CIRCLE (GROUT)	10

RACK20

7"Out X 17"H X 20"W



**OSCILLATING
BLADES**

Oscillating Blades

Part #	Contents
RACK20	Black Header - 10 Prong
H-9	Oscillating Blade Header
DIS-OSC	Oscillating Blades





INTERNATIONAL TOOL MANUFACTURING
150 Express St. Plainview, NY 11803

(516) 738-0388 • (800) 247-5696

ITM® Fax (516) 279-1106



KC



CC



Industrial Wire Cups



Steel Stainless Cast Iron



Brass Aluminum Copper

- ◆ Individually Blister Packaged
- ◆ Industrial Quality
- ◆ 5/8" - 11 SPINDLE



ANGLE GRINDER

Part #	Size	Description	Wire Type	Max RPM
KCC075	2-3/4"	Knotted Cup	.020 Carbon Steel	12,500
KCS075	2-3/4"	Knotted Cup	.020 Stainless Steel	12,500
KCC100	4"	Knotted Cup	.020 Carbon Steel	8,500
KCC150	6"	Knotted Cup	.020 Carbon Steel	6,500
CCC075	3"	Crimped Cup	.014 Carbon Steel	12,500
CCC100	4"	Crimped Cup	.014 Carbon Steel	8,500

USE RED - NUT WIRE CUP
ADAPTER IN CLOCKWISE
ROTATION ONLY.



The Red-Nut Wire Cup Adapter

Part #	Description
REDNUT	5/8"-11 Bolt and Nut Adapter

- ◆ 3-Flat Shank
- ◆ For Use in 1/2" Handheld Drills
- ◆ Light Grinding



1/2" DRILL





Stringer Bead Wheel



Industrial Wire Wheels

Part #	Size	Description	Wire Type	Max RPM
TKW100	4"	Twist Knot Wheel	.020 Carbon Steel	12,500
SBW100	4"	Stringer Bead Wheel	.020 Carbon Steel	12,500
SBS100	4"	Stringer Bead Wheel	.020 Stainless Steel	12,500
SBW150	5"	Stringer Bead Wheel	.020 Carbon Steel	12,500
SBW175	7"	Stringer Bead Wheel	.020 Carbon Steel	9,000
WBB120	12"	Walk Behind Wire Brush	.035 Carbon Steel (1" Spindle)	3,600



- ◆ Individually Blister Packaged
- ◆ Industrial Quality
- ◆ 5/8" - 11 SPINDLE

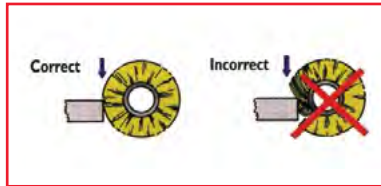

APPLICATION	KNOTTED CUP WIRE BRUSH	CRIMPED CUP WIRE BRUSH	TWIST KNOT WIRE BRUSH	STRINGER BEAD WIRE BRUSH
DEBURRING (FINE)	⊕	⊕		
DEBURRING (COURSE)			⊕	⊕
EDGE BLENDING	⊕	⊕		
WELD, SCALE REMOVAL			⊕	⊕
WELD PREP				⊕
SURFACE FINISHING	⊕	⊕		
RUST OXIDE (FINE)	⊕	⊕		
RUST OXIDE (COARSE)			⊕	⊕
PAINT REMOVAL	⊕	⊕		
ROUGHENING	⊕	⊕	⊕	⊕
CLEANING	⊕	⊕		⊕
FLASH REMOVAL		⊕	⊕	
TOOL MARK REMOVAL		⊕	⊕	
EXPANSION JOINT		⊕	⊕	





HSS Bell Hanger - Feeler Bits With Fish Hole (Electrical / Wire)

- ◆ Fish Hole In Flute For Pulling Wire
- ◆ Special Point For Fast Drilling In Wood & Metal
- ◆ Tapering For Quick Chip Clearance
- Telephone Installation
- Burglar Alarms
- Wire & Cable Applications

Part #	Size	OAL	Shank	Qty.	Part #	Size	OAL	Shank	Qty.
308BH1200	3/16"	12"	3/16"	1	308BH2403	3/8"	24"	3/8"	1
308BH1800	3/16"	18"	3/16"	1	308BH3003	3/8"	30"	3/8"	1
308BH1201	1/4"	12"	1/4"	1	308BH4203	3/8"	42"	3/8"	1
308BH1801	1/4"	18"	1/4"	1	308BH4803	3/8"	48"	3/8"	1
308BH2401	1/4"	24"	1/4"	1	308BH1806	7/16"	18"	3/8"	1
308BH3001	1/4"	30"	1/4"	1	308BH1204	1/2"	12"	1/2"	1
308BH4201	1/4"	42"	1/4"	1	308BH1804	1/2"	18"	1/2"	1
308BH1202	5/16"	12"	5/16"	1	308BH2404	1/2"	24"	3/8"	1
308BH1802	5/16"	18"	5/16"	1	308BH3004	1/2"	30"	3/8"	1
308BH2402	5/16"	24"	5/16"	1	308BH4204	1/2"	42"	3/8"	1
308BH1203	3/8"	12"	3/8"	1	308BH4804	1/2"	48"	3/8"	1
308BH1803	3/8"	18"	3/8"	1	308BH1858	5/8"	18"	1/2"	1
					308BH1805	3/4"	18"	1/2"	1
					308BH1810	1"	18"	1/2"	1



Carbide Tip Bell Hanger - Feeler Bits With Fish Hole (Electrical / Wire)

- ◆ Fish Hole In Flute For Pulling Wire
- ◆ Special Point For Fast Drilling In Masonry & Wood
- Telephone Installation
- Burglar Alarms
- Wire & Cable Applications

Part #	Size	OAL	Shank	Qty.	Part #	Size	OAL	Shank	Qty.
308CT1301	1/4"	13"	1/4"	1	308CT1304	1/2"	13"	3/8"	1
308CT1801	1/4"	18"	1/4"	1	308CT1804	1/2"	18"	3/8"	1
308CT2401	1/4"	24"	1/4"	1	308CT2404	1/2"	24"	3/8"	1
308CT1302	5/16"	13"	5/16"	1	308CT3004	1/2"	30"	3/8"	1
308CT1802	5/16"	18"	5/16"	1	308CT1305	3/4"	13"	1/2"	1
308CT2402	5/16"	24"	5/16"	1	308CT1805	3/4"	18"	1/2"	1
308CT1303	3/8"	13"	3/8"	1					
308CT1803	3/8"	18"	3/8"	1					
308CT2403	3/8"	24"	3/8"	1					
308CT3003	3/8"	30"	3/8"	1					
308CT3638	3/8"	36"	3/8"	1					



Great For Acrylics!



- ◆ Precision Ground Flute
- ◆ Center Spur
- ◆ Two Shoulder Cutting Spurs
- ◆ Industrial Quality



Part # 309BP0007
7 Pc. Set Woodworking
 1/8" - 3/16" - 1/4" - 5/16" - 3/8" -
 7/16" - 1/2"
List \$55.19



Brad Point Wood Drill

Part #	Size	OAL	Shank	Qty.
309BP0864	1/8"	2-1/2"	1/8"	1
309BP1064	5/32"	3-1/8"	5/32"	1
309BP1264	3/16"	3-3/8"	3/16"	1
309BP1664	1/4"	4"	1/4"	1
309BP2064	5/16"	4-5/8"	5/16"	1
309BP2464	3/8"	4-7/8"	3/8"	1
309BP2864	7/16"	5-1/2"	3/8"	1
309BP3264	1/2"	6"	3/8"	1
309BP4064	5/8"	7"	3/8"	1
309BP4864	3/4"	7-3/4"	3/8"	1
309BP5664	7/8"	8-1/8"	3/8"	1
309BP6464	1"	8-1/2"	3/8"	1



Electrician's Flex Bit With Screw Point - Stretch Bit

Part #	Size	X	OAL	Shank	Application
308FB2438	3/8"	X	24"	3/16"	Popular with alarm & communication installers for pulling light wire.
308FB3638	3/8"	X	36"	3/16"	
308FB5438	3/8"	X	54"	3/16"	
308FB7238	3/8"	X	72"	3/16"	
308FB2412	1/2"	X	24"	3/16"	Popular with alarm & communication installers for pulling light wire.
308FB3612	1/2"	X	36"	3/16"	
308FB5412	1/2"	X	54"	3/16"	
308FB7212	1/2"	X	72"	3/16"	
308FB5496	9/16"	X	54"	3/16"	Popular with alarm & communication installers for pulling light wire.
308FB7296	9/16"	X	72"	3/16"	
308FB5434	3/4"	X	54"	3/16"	Popular with alarm & communication installers for pulling light wire.
308FB7234	3/4"	X	72"	3/16"	



- ◆ Screw Point
- ◆ Self Drilling
- ◆ Fish Hole On Each End
- ◆ Flexible Shaft
- ◆ Sold Individually



1/2" DRILL



FISH HOLE ON SHANK



Stretch Bits are constructed of a high carbon steel self-feed auger bit, permanently brazed to a flexible shaft. This tool can be inserted through small wall openings enabling the operator to bore holes through studs within the wall cavities without damaging finished walls or ceilings. Eye Holes are provided at each end of the Stretch Bits which allow easy retrieval of wires from either direction after drilling.

Steering Guide

Part #	Description	Application
308FBG	Steering Guide	Helps manipulate bits while within the wall cavity.



Circular Saw Blades

Part #	Size	Box Qty.
DS-58-724	7-1/4" X 24T	25
CS-58-824	8-1/4" X 24T	25
CS-58-840	8-1/4" X 40T	25



- ◆ Tungsten Carbide Tipped
- ◆ 5/8" Arbor With Diamond Knock Out
- ◆ 7000 RPM Maximum
- ◆ Hard Body 38-42 Rc.
- ◆ K20 Tungsten Carbide Grade
- ◆ Individually Protected
- ◆ Individually Barcoded
- ◆ Imported

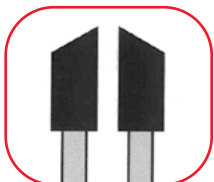

ALTERNATE TOP BEVELED TEETH



CIRCULAR SAW





118° POINT



- ◆ M2 HSS
- ◆ Straight Shank To 1/2", Then Reduced
- ◆ Sharp Cutting Edge To Drill In Many Different Materials



- ⊙ Precision point angle for effective penetration through steel and wood.
- ⊙ Extra length flute with continuous cutting edges for drilling deep holes and fast chip removal.
- ⊙ Reduced shank fits all drill motors with 1/2" chucks.
- ⊙ Non-slip grips prevent the bit from spinning in the chuck.



12" Long Boy - M2 HSS

Part #	Size	Dec.	OAL	Flute	Qty.
216HS0864	1/8"	.1250	12"	9"	1
216HS1264	3/16"	.1875	12"	9"	1
216HS1464	7/32"	.2188	12"	9"	1
216HS1664	1/4"	.2500	12"	9"	1
216HS1864	9/32"	.2812	12"	9"	1
216HS2064	5/16"	.3125	12"	9"	1
216HS2464	3/8"	.3750	12"	9"	1
216HS2864	7/16"	.4375	12"	9"	1
216HS3264	1/2"	.5000	12"	9"	1
216HS3664	9/16"	.5625	12"	9"	1
216HS4064	5/8"	.6250	12"	9"	1
216HS4464	11/16"	.6875	12"	9"	1
216HS4864	3/4"	.7500	12"	9"	1
216HS5264	13/16"	.8125	12"	9"	1
216HS5664	7/8"	.8750	12"	9"	1
216HS6064	15/16"	.9375	12"	9"	1
216HS6464	1"	1.000	12"	9"	1
216HS7264	1-1/8"	1.1250	12"	9"	1

18" Long Boy - M2 HSS

Part #	Size	Dec.	OAL	Flute	Qty.
217HS1664	1/4"	.2500	18"	14"	1
217HS2064	5/16"	.3125	18"	14"	1
217HS2464	3/8"	.3750	18"	14"	1
217HS3064	15/32"	.4688	18"	14"	1
217HS3264	1/2"	.5000	18"	14"	1
217HS4064	5/8"	.6250	18"	14"	1
217HS4864	3/4"	.7500	18"	14"	1



Drywall Cutter - M2 HSS

Part #	Size	OAL	Qty.
DW-018	1/8"	2-3/4"	1
DW-018A	1/8"	2-3/4"	10
DW-018B	1/8"	2-3/4"	25
DW-316	3/16"	3-1/4"	1
DW-316A	3/16"	3-1/4"	10
DW-316B	3/16"	3-1/4"	25



- ◆ 1/8" & 1/4" Shank
- ◆ Electrical Boxes
- ◆ Air Ducts

SOLD INDIVIDUALLY OR IN BULK PACKS



Self Feed (Multipur) Wood Drill

Part #	Size	MM	Pipe Entrance	Tubing Entrance	Cutting Flute	Shank
306ST-1	1"	25.4	1/2"	7/8"	1"	7/16"
306ST-2	1-1/8"	28.6	1/2"	1"	1"	7/16"
306ST-3	1-1/4"	31.8	3/4"	1-1/8"	1"	7/16"
306ST-4	1-3/8"	34.9	1"	1-1/4"	1"	7/16"
306ST-5	1-1/2"	38.1	1"	1-3/8"	1"	7/16"
306ST-6	1-3/4"	44.5	1-1/4"	1-1/2"	1"	7/16"
306ST-7	2"	50.8	1-1/2"	1-7/8"	1"	7/16"
306ST-8	2-1/8"	54.0	1-1/2"	2"	1"	7/16"
306ST-9	2-1/4"	57.2	1-1/2"	2-1/8"	1"	7/16"
306ST-10	2-9/16"	65.1	2"	2-1/2"	1"	7/16"
306ST-11	3"	76.2	2-1/2"	2-7/8"	2"	7/16"
306ST-12	3-5/8"	92.1	3"	3-1/2"	2"	7/16"
306ST-13	4-5/8"	117.5	4"	4-1/2"	2"	7/16"



- ◆ 7/16" Hex Impact Shank
- ◆ Fast Continuous and Self Feeding
- ◆ Deep Holes
- ◆ Double End Screw
- ◆ Extra Screw & Wrench
- ◆ Industrial Quality
- ◆ Plumbing
- ◆ Rough In Work



SOLD INDIVIDUALLY
1 PER TUBE.



Replacement Screw Points

Part #	Size	Fits
SP0001	1/4"	1-1/4" to 2-9/16"
SP0002	1/4"	3" to 4-5/8"

Screw Points come with replacement set screw and wrench.



Extensions for Ship Auger & Multispur

Part #	Size	For Shank	Ø
307HEX-1	7/16" x 9-1/2"	7/16"	7/8"
307HEX-2	7/16" x 12"	7/16"	7/8"
307HEX-3	7/16" x 18"	7/16"	7/8"
307HEX-4	7/16" x 24"	7/16"	7/8"

7/16" Extensions - Pass Thru Hole
Drill Diameter Must Be Larger Than 7/8".

- ◆ 7/16" Hex Impact Shank
- ◆ HEX Wrench Included
- ◆ 2 Set Screws
- ◆ Sold Individually



Extensions for Spade Bit

Quick Insert / Quick Spring Out
Chuck Extensions.
SOLD INDIVIDUALLY.

1/4" Extensions - Pass Thru Hole
Drill Diameter Must Be Larger Than 5/8".



Part #	Size	For Shank	Ø
EXT-300	1/4" x 12"	1/4"	5/8"
EXT-500	1/4" x 18"	1/4"	5/8"

- ◆ 1/4" Hex Impact Shank
- ◆ Quick-Change
- ◆ 1 PC. Construction
- ◆ Industrial Quality
- ◆ Sold Individually



IMPACT
1/4" HEX IMPACT SHANK



- ◆ 1/4" Hex Impact Shank
- ◆ Cold Forged
- ◆ Full Length Treated
- ◆ Machine Finish Cutting Groove
- ◆ Rust Protection
- ◆ Wing Tip Design
- ◆ Individually Stamped With Size
- ◆ Industrial Quality



SOLD INDIVIDUALLY
1 PER POUCH.



IMPACT
1/4" HEX IMPACT SHANK



- ◆ 1/4" Hex Impact Shank
- ◆ Cold Forged
- ◆ Full Length Treated
- ◆ Self Feeding Tip
- ◆ Rust Protection
- ◆ Curved Paddle
- ◆ Individually Stamped With Size
- ◆ Industrial Quality



6" Spade Wood Drill

Part #	Size	OAL	Qty.
300SB1664	1/4"	6"	1
300SB2064	5/16"	6"	1
300SB2464	3/8"	6"	1
300SB2864	7/16"	6"	1
300SB3264	1/2"	6"	1
300SB3664	9/16"	6"	1
300SB4064	5/8"	6"	1
300SB4464	11/16"	6"	1
300SB4864	3/4"	6"	1
300SB5264	13/16"	6"	1
300SB5664	7/8"	6"	1
300SB6064	15/16"	6"	1
300SB6464	1"	6"	1
300SB7264	1-1/8"	6"	1
300SB8064	1-1/4"	6"	1
300SB8864	1-3/8"	6"	1
300SB9664	1-1/2"	6"	1



Quick Change Extensions
P. 69

16" Spade Wood Drill

Part #	Size	OAL	Qty.
301SB1664	1/4"	16"	1
301SB2464	3/8"	16"	1
301SB3264	1/2"	16"	1
301SB4064	5/8"	16"	1
301SB4864	3/4"	16"	1
301SB5664	7/8"	16"	1
301SB6464	1"	16"	1
301SB8864	1-3/8"	16"	1

Part # 300-ST-06

6 Pc. Spade Bit Set
3/8"- 1/2"- 5/8"
3/4"- 7/8"- 1"



REDLINE

6" Self Feed Spade Wood Drill

Part #	Size	OAL	Qty.
SX-1664	1/4"	6"	1
SX-2064	5/16"	6"	1
SX-2464	3/8"	6"	1
SX-2864	7/16"	6"	1
SX-3264	1/2"	6"	1
SX-3664	9/16"	6"	1
SX-4064	5/8"	6"	1
SX-4464	11/16"	6"	1
SX-4864	3/4"	6"	1
SX-5264	13/16"	6"	1
SX-5664	7/8"	6"	1
SX-6064	15/16"	6"	1
SX-6464	1"	6"	1
SX-7264	1-1/8"	6"	1
SX-8064	1-1/4"	6"	1
SX-8864	1-3/8"	6"	1
SX-9664	1-1/2"	6"	1



SOLD INDIVIDUALLY
1 PER CLIP.





REDLINE

Self Feed Twister Wood Drill



Part #	Size	OAL	Qty.
THX-2464	3/8"	6"	1
THX-3264	1/2"	6"	1
THX-3664	9/16"	6"	1
THX-4064	5/8"	6"	1
THX-4864	3/4"	6"	1
THX-5664	7/8"	6"	1
THX-6464	1"	6"	1
THX-7264	1-1/8"	6"	1
THX-8064	1-1/4"	6"	1

- ◆ 1/4" Hex Impact Shank
- ◆ Self Feeding
- ◆ 4-Cutting Edges
- ◆ Rust Protection
- ◆ Individually Stamped With Size
- ◆ Industrial Quality



IMPACT
1/4" HEX IMPACT SHANK



SOLD INDIVIDUALLY
1 PER CLIP.

PART

BC-1

7/16" HEX POWER SHANK
WORKS ON ALL SIZES OF
BUTCHER HOLE SAWS

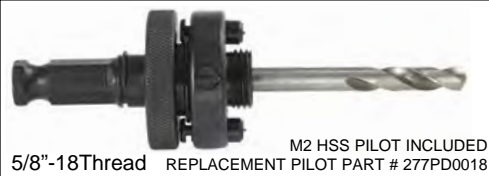

5/8"-18Thread M2 HSS PILOT INCLUDED
REPLACEMENT PILOT PART # 277PD0018

PART

BC-8P

CARBIDE PILOT DRILL



4-1/2" OAL

PART

BC-6S

WOOD SPADE PILOT DRILL



6" OAL

Carbide Tipped Wood Hole Saw - The Butcher

Part #	Size	Teeth	Use Arbor
BCHR-35	1-3/8"	2	ARB-5
BCHR-44	1-3/4"	2	ARB-5
BCHR-54	2-1/8"	3	ARB-5
BCHR-57	2-1/4"	3	ARB-5
BCHR-65	2-9/16"	3	ARB-5
BCHR-70	2-3/4"	3	ARB-5
BCHR-76	3"	3	ARB-5
BCHR-92	3-5/8"	3	ARB-5
BCHR-102	4"	3	ARB-5
BCHR-108	4-1/4"	3	ARB-5
BCHR-118	4-5/8"	3	ARB-5
BCHR-133	5-1/4"	3	ARB-5
BCHR-159	6-1/4"	3	ARB-5



Carbide
Teeth

2-1/8" CUTTING DEPTH

1 HOLE SAW PER
BLISTER PACK.
ARBOR NOT INCLUDED.

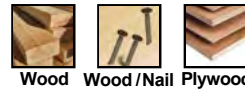

- ◆ Tungsten Carbide Teeth
- ◆ 3 Carbide Teeth
- ◆ High Wear Resistance
- ◆ 2-1/8" Cutting Depth
- ◆ Premium Quality
- ◆ Red Finish





Wood



Timber



Cuts

Nails



CCA Poles



Railroad Ties

- ◆ 7/16" Hex Impact Shank
- ◆ Carbide Tipped
- ◆ Heat Treated
- ◆ Machine Ground
- ◆ Single Cutter
- ◆ Side Lip
- ◆ Self-Feeding Screw Point

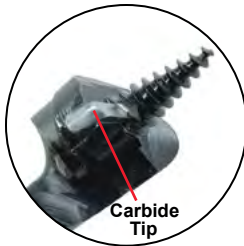

Carbide Tip



AUSTRIA



1/2" DRILL



IMPACT DRIVER

SOLD INDIVIDUALLY
1 PER POUCH.

Carbide Tipped Auger Wood Drills

Part #	Size	OAL	Drilling	Shank
CPP-12122	1/2"	24"	21"	7/16"
CPP-13123	1/2"	36"	33"	7/16"
CPP-14911	9/16"	18"	15"	7/16"
CPP-15912	9/16"	24"	21"	7/16"
CPP-17581	5/8"	18"	15"	7/16"
CPP-18582	5/8"	24"	21"	7/16"
CPP-21162	11/16"	24"	21"	7/16"
CPP-22163	11/16"	36"	33"	7/16"
CPP-24342	3/4"	24"	21"	7/16"
CPP-25343	3/4"	36"	33"	7/16"
CPP-27132	13/16"	24"	21"	7/16"
CPP-28648	13/16"	48"	45"	7/16"
CPP-29781	7/8"	18"	15"	7/16"
CPP-30782	7/8"	24"	21"	7/16"
CPP-31783	7/8"	36"	33"	7/16"
CPP-33562	15/16"	24"	21"	7/16"
CPP-34563	15/16"	36"	33"	7/16"
CPP-36121	1"	24"	21"	7/16"
CPP-37133	1"	36"	33"	7/16"



Utility Poles



Timber



Wood



- ◆ 7/16" Hex Impact Shank
- ◆ Heat Treated
- ◆ Wide Flute Design for Chip Removal
- ◆ Double Spur
- ◆ Self-Feeding Screw Point



1/2" DRILL



IMPACT DRIVER

Lineman Pole Auger Wood Drills

Part #	Size	OAL	Drilling	Shank
307LD3664	9/16"	18"	15"	7/16"
307LD4064	5/8"	18"	15"	7/16"
307LD4464	11/16"	18"	15"	7/16"
308LD4464	11/16"	24"	21"	7/16"
309LD4464	11/16"	36"	33"	7/16"
307LD5264	13/16"	18"	15"	7/16"
308LD5264	13/16"	24"	21"	7/16"
309LD5264	13/16"	36"	33"	7/16"
307LD6064	15/16"	18"	15"	7/16"
308LD6064	15/16"	24"	21"	7/16"
309LD6064	15/16"	36"	33"	7/16"
307LD6464	1"	18"	15"	7/16"
307LD8064	1-1/4"	18"	15"	7/16"
307LD9664	1-1/2"	18"	15"	7/16"

SOLD INDIVIDUALLY
1 PER TUBE.



AUSTRIA



8" Long Ship Auger Wood Drill

Part #	Size	Size In 16ths	OAL	Hex Shank
302SL3264	1/2"	8	8"	7/16"
302SL3664	9/16"	9	8"	7/16"
302SL4064	5/8"	10	8"	7/16"
302SL4464	11/16"	11	8"	7/16"
302SL4864	3/4"	12	8"	7/16"
302SL5264	13/16"	13	8"	7/16"
302SL5664	7/8"	14	8"	7/16"
302SL6064	15/16"	15	8"	7/16"
302SL6464	1"	16	8"	7/16"
302SL7264	1-1/8"	18	8"	7/16"
302SL8064	1-1/4"	20	8"	7/16"
302SL8864	1-3/8"	22	8"	7/16"
302SL9664	1-1/2"	24	8"	7/16"

Cuts
Nails



- ◆ 7/16" Hex Impact Shank
- ◆ 6" Twist Length
- ◆ Heat Treated
- ◆ Deep Throat
- ◆ Single Twist
- ◆ Single Cutter
- ◆ Self-Feeding Screw Point



18" Long Ship Auger Wood Drill

Part #	Size	Size In 16ths	OAL	Hex Shank
303SL2464	3/8"	6	18"	7/16"
303SL2864	7/16"	7	18"	7/16"
303SL3264	1/2"	8	18"	7/16"
303SL3664	9/16"	9	18"	7/16"
303SL4064	5/8"	10	18"	7/16"
303SL4464	11/16"	11	18"	7/16"
303SL4864	3/4"	12	18"	7/16"
303SL5264	13/16"	13	18"	7/16"
303SL5664	7/8"	14	18"	7/16"
303SL6064	15/16"	15	18"	7/16"
303SL6464	1"	16	18"	7/16"
303SL7264	1-1/8"	18	18"	7/16"
303SL8064	1-1/4"	20	18"	7/16"
303SL8864	1-3/8"	22	18"	7/16"
303SL9664	1-1/2"	24	18"	7/16"

Cuts
Nails



- ◆ 7/16" Hex Impact Shank
- ◆ 15" Twist Length
- ◆ Heat Treated
- ◆ Deep Throat
- ◆ Single Twist
- ◆ Single Cutter
- ◆ Self-Feeding Screw Point



Made Of Premium Steel, Ship Auger Drills Are For Boring Bulkheads And General Timber.



7/16" Ship Auger Extensions
P. 69



7" Sharpening File - Ship Augers

Part #	Description
303SL-F1	7" Sharpening File

SOLD INDIVIDUALLY
1 PER TUBE.





INTERNATIONAL TOOL MANUFACTURING
150 Express St. Plainview, NY 11803

(516) 738-0388 • (800) 247-5696

ITM® Fax (516) 279-1106



V GROOVE™
#1 IN TILE DRILLING



- ♦ 20 Holes Drilled In Grade 5 Porcelain Tile
- ♦ Precision Design
- ♦ Unique Carbide Head
- ♦ Carbide Serrations



Rotation Only!

PULSE & PUSH™
Method of Drilling



1. Pulse the drill and apply pressure.
2. Repeat this step 3 times.
3. Dip carbide tip in water. Repeat **PULSE & PUSH™** until hole is drilled.



20 Holes Drilled In Porcelain Tile Video

Take a Picture of QR Code

Unique Carbide Head Design

Carbide Serrations To Evacuate Fine Dust.

No Walk Carbide Point



V GROOVE Tile Bit - Skin Card

Part #	Size	X	OAL	Drilling	Shank	Qty.
VG-4001	1/8"	X	3"	2"	1/8"	1
VG-3002	3/16"	X	3"	2"	3/16"	1
VG-4002	3/16"	X	4"	2-3/4"	3/16"	1
VG-6001	3/16"	X	6"	4-1/4"	3/16"	1
VG-8002	3/16"	X	8"	6-1/4"	3/16"	1
VG-6026	7/32"	X	6"	4-1/4"	7/32"	1
VG-4003	1/4"	X	4"	2-3/4"	1/4"	1
VG-6002	1/4"	X	6"	4-1/4"	1/4"	1
VG-6003	5/16"	X	6"	4-1/4"	5/16"	1
VG-6004	3/8"	X	6"	4-1/4"	3/8"	1
VG-6716	7/16"	X	6"	4-1/4"	3/8"	1
VG-6005	1/2"	X	6"	4-1/4"	3/8"	1



V GROOVE Tile Bit - Bulk Pack

Part #	Size	X	OAL	Drilling	Shank	Qty.
VG-4001B	1/8"	X	3"	2"	1/8"	25
VG-3002B	3/16"	X	3"	2"	3/16"	25
VG-4002B	3/16"	X	4"	2-3/4"	3/16"	25
VG-6001B	3/16"	X	6"	4-1/4"	3/16"	25
VG-4003B	1/4"	X	4"	2-3/4"	1/4"	25
VG-6002B	1/4"	X	6"	4-1/4"	1/4"	25
VG-6003B	5/16"	X	6"	4-1/4"	5/16"	25
VG-6716B	7/16"	X	6"	4-1/4"	7/16"	25



IMPACT
1/4" HEX IMPACT SHANK



V GROOVE Tile Bit - Impact - Skin Card

Part #	Size	X	OAL	Drilling	Shank	Qty.
VH-3002	3/16"	X	3"	2"	HEX	1
VH-4003	1/4"	X	4"	3"	HEX	1



V GROOVE Tile Bit - Impact - Bulk Pack

Part #	Size	X	OAL	Drilling	Shank	Qty.
VH-3002B	3/16"	X	3"	2"	HEX	25
VH-4003B	1/4"	X	4"	3"	HEX	25



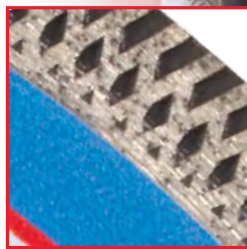

Turbo Mesh Rim
Ultra-Thin Kerf for chipless edges.

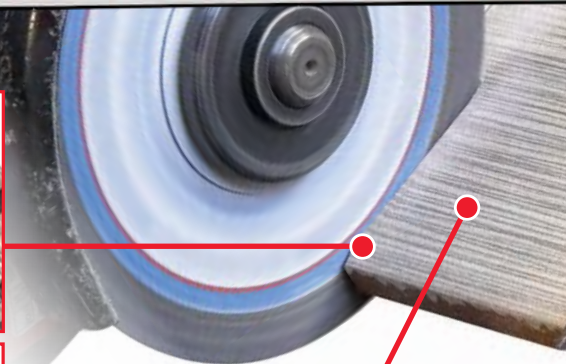

GRADE 5
PORCELAIN TILE



V GROOVE Diamond Tile Blade - Ultra-Thin Kerf

Part #	Size	Arbor	Kerf	RPM	Qty.
PL-45	4-1/2"	7/8"-5/8"	0.050	13300	1
PL-45-A	4-1/2"	7/8"-5/8"	0.050	13300	10
PL-10	10"	5/8"	0.063	6115	1

- ◆ Ultra-Thin Kerf
- ◆ Wet Or Dry Cutting
- ◆ Reinforced Hub
- ◆ 10 mm Segments
- ◆ Brass Arbor
- ◆ Sold Individually or Box of 10



CUTTING



REMOVABLE DOUBLE SIDED
DIAMOND DISC.
(HEX KEY INCLUDED)



GRINDING

Diamond Grinding & Cutting Disc - Double Sided

Part #	Size	Arbor	Kerf	RPM	Qty.
DDD-40	4"	5/8"-11	0.100	15000	1
DDD-45	4-1/2"	5/8"-11	0.100	13300	1
DDD-50	5"	5/8"-11	0.100	12000	1
DDD-70	7"	5/8"-11	0.100	8730	1
DDD-90	9"	5/8"-11	0.100	6790	1



- ◆ Double Sided
- ◆ Wet Or Dry Cutting
- ◆ Vacuum Brazed Diamond
- ◆ 5/8"-11 Thread
- ◆ Sold Individually



REVERSIBLE DISC GIVES DOUBLE THE LIFE.
FLIP THE DISC AFTER ONE SIDE IS WORN OUT.



WHITE DIAMOND



- ◆ 1/4" Hex Impact Shank
- ◆ Dry Cutting
- ◆ Vacuum Brazed Diamond
- ◆ Wax Filled For Lubrication up To 1/2" Diameter



IMPACT
1/4" HEX IMPACT SHANK



White Diamond Tile Bit - 1/4" Hex Shank

Part #	Size	X	OAL	Drilling	Qty.
HEX-12	3/16"	X	2-5/8"	1-1/4"	1
HEX-14	1/4"	X	2-5/8"	1-1/4"	1
HEX-16	5/16"	X	3-1/8"	1-1/4"	1
HEX-18	3/8"	X	3-1/8"	1-1/4"	1
HEX-20	1/2"	X	3-1/8"	1-1/4"	1
HEX-22	5/8"	X	2-3/4"	1-1/4"	1
HEX-24	3/4"	X	2-3/4"	1-1/4"	1
HEX-26	7/8"	X	2-3/4"	1-1/4"	1
HEX-28	1"	X	2-3/4"	1-1/4"	1



- ◆ Vacuum Brazed Diamond
- ◆ Dry Cutting
- ◆ 5/8"-11 Thread



White Diamond Tile Bit - 5/8"-11 Thread

Part #	Size	X	OAL	Drilling	Qty.
ANG-26	7/8"	X	2-3/8"	1-1/4"	1
ANG-28	1"	X	2-3/8"	1-1/4"	1
ANG-30	1-1/8"	X	2-3/8"	1-1/4"	1
ANG-32	1-1/4"	X	2-3/8"	1-1/4"	1
ANG-34	1-3/8"	X	2-3/8"	1-1/4"	1
ANG-36	1-1/2"	X	2-3/8"	1-1/4"	1
ANG-38	2"	X	2-3/8"	1-1/4"	1
ANG-40	2-1/2"	X	2-3/8"	1-1/4"	1



Point Adapter

Part #	Size	Qty.
PAD-5811	Point Adapter (5/8"-11)	1

- ◆ Fits Diamond Milling / Countersink / Holesaw
- ◆ 5/8"-11 Thread
- ◆ 3/8" Shank

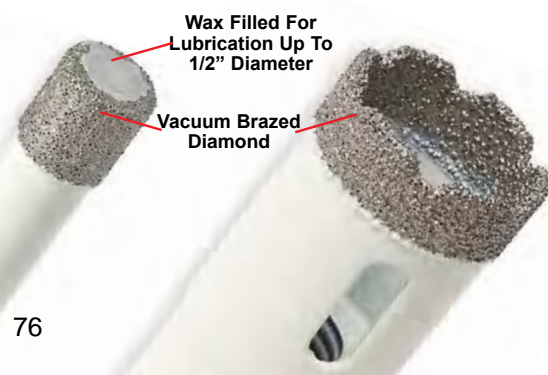



V Tip Tile Countersink

Part #	Size	Qty.
VT-1	For 3/16" & 1/4" Holes	1



IMPACT
1/4" HEX IMPACT SHANK



1. Drill



2. Countersink

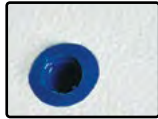

3. Set Anchor



- ◆ 1/4" Hex Impact Shank
- ◆ For 3/16" & 1/4"
- ◆ Vacuum Brazed Diamond
- ◆ Set Flush Anchors in Tile

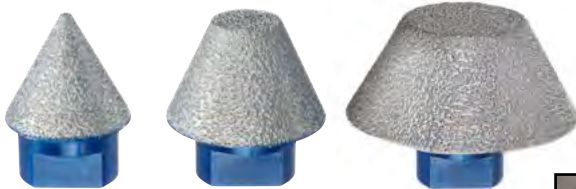

POINT-1

POINT-2

POINT-3



1.



2.

Diamond Countersink

Part #	Size	Qty.
POINT-1	Hole Sizes - 3/16" - 1-3/8"	1
POINT-2	Hole Sizes - 1" - 1-7/8"	1
POINT-3	Hole Sizes - 1-7/8" - 3"	1

- ◆ Vacuum Brazed Diamond
- ◆ Wet Or Dry Cutting
- ◆ 5/8"-11 Thread
- ◆ #45/50 Diamond Grit
- ◆ Cleaning Rough Edges On Drilled Circle Holes

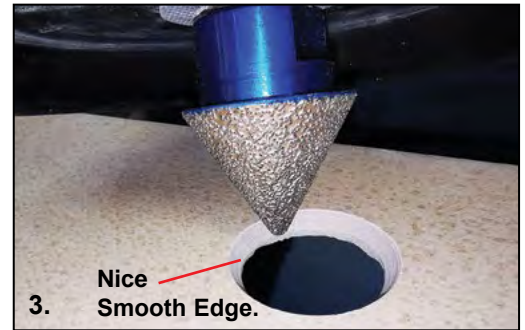

Diamond Milling Cutter

Part #	Size	OAL	Qty.
DMC-6	1/4"	2-7/8"	1
DMC-8	5/16"	2-7/8"	1
DMC-10	3/8"	2-7/8"	1
DMC-16	5/8"	2-7/8"	1
DMC-20	3/4"	2-7/8"	1
DMC-25	1"	2-7/8"	1
DMC-50	2"	2-7/8"	1
DMC-75	3"	2-7/8"	1



- ◆ Vacuum Brazed Diamond
- ◆ Wet Or Dry Cutting
- ◆ 5/8"-11 Thread
- ◆ #45/50 Diamond Grit
- ◆ Milling Inside Circle Or Half Circle For Pipe



1.



2.



3.



GLASS DRILL

ROTATION ONLY
Fast drilling speeds and lubricant are recommended when using these drills.

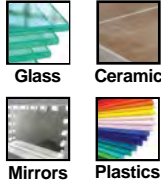

Glass Drills - STANDARD TIP

Part #	Size	OAL	Shank
GL-0864	1/8"	2-1/4"	1/8"
GL-1264	3/16"	2-3/4"	3/16"
GL-1664	1/4"	3"	1/4"
GL-2064	5/16"	3-1/4"	1/4"
GL-2464	3/8"	3-1/2"	3/8"
GL-3264	1/2"	4"	3/8"



◆ Tungsten Carbide Tip



Glass Drills - Bulk 25 Pack

Part #	Size	OAL	Shank
GL-1264B	3/16"	2-3/4"	3/16"
GL-1664B	1/4"	3"	1/4"



USE WATER

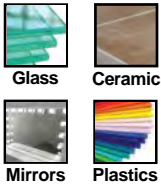

Glass Drills - QUAD-CUTTER

Part #	Size	OAL	Shank
QG-0012	3/16"	2-3/4"	3/16"
QG-0014	1/4"	3"	1/4"
QG-0016	5/16"	3-1/4"	1/4"
QG-0018	3/8"	3-1/2"	3/8"
QG-0020	1/2"	4"	3/8"

- ◆ Tungsten Carbide Tip
- ◆ Sold Individually



Glass Drills - RAZOR CUTTER

Part #	Size	OAL	Shank
RAZ-4001	1/8"	3"	1/8"
RAZ-4002	3/16"	3"	3/16"
RAZ-4003	1/4"	4"	1/4"
RAZ-4004	5/16"	4"	1/4"
RAZ-4005	3/8"	4"	5/16"
RAZ-4006	1/2"	4"	3/8"



- ◆ Diamond Segments
- ◆ Wet Drilling
- ◆ Core Extraction
- ◆ Rotation Only
- ◆ Sold Individually



Blu Diamond Tile Bit

Part #	Size	OAL	Shank
BLU-1	1/4"	2"	3/8"
BLU-3	5/16"	2"	3/8"
BLU-4	3/8"	2-1/2"	3/8"
BLU-5	1/2"	2-1/2"	3/8"
BLU-6	3/4"	2-3/4"	3/8"
BLU-8	1"	2-3/4"	3/8"



Glass Drills - Bulk 25 Pack

Part #	Size	OAL	Shank
RAZ-4002B	3/16"	3"	3/16"
RAZ-4003B	1/4"	4"	1/4"



Part # RAZ-SET5
5 Pc. RAZOR
Glass Drill Set
1/8", 3/16", 1/4", 3/8", 1/2"





Multi Purpose Drills - CARBIDE TIP

Part #	Size	OAL	Drilling	Shank
BLU-0864	1/8"	2-1/2"	1-1/2"	1/8"
BLU-1064	5/32"	3"	2"	5/32"
BLU-1264	3/16"	3-1/2"	2-1/2"	3/16"
BLU-1264-L	3/16"	6"	5"	3/16"
BLU-1664	1/4"	4"	3"	1/4"
BLU-1664-L	1/4"	6"	5"	1/4"
BLU-1664-XL	1/4"	10"	9"	1/4"
BLU-2064	5/16"	4"	3"	5/16"
BLU-2064-XL	5/16"	10"	9"	5/16"
BLU-2464	3/8"	4-1/2"	3-1/2"	3/8"
BLU-2464-XL	3/8"	12"	11"	3/8"
BLU-3264-L	1/2"	6"	5"	1/2"
BLU-3264-XL	1/2"	12"	11"	1/2"
BLU-4064-L	5/8"	6"	5"	1/2"



- ◆ Positive Carbide Tip with Centering Point
- ◆ Tungsten Carbide
- ◆ Angle Tip 118°
- ◆ 4-Sided Sharpening
- ◆ ANSI Specification
- ◆ Sold Individually



ROTATION ONLY
Moderate drilling speeds and lubricant are recommended when using these drills.

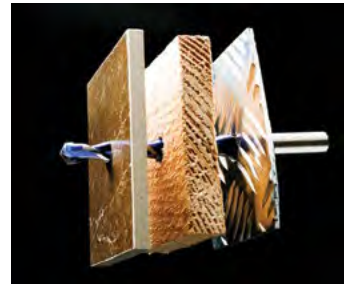

Part # BLU-SET5
5 Pc. Multi Purpose Drill Set
1/8", 3/16", 1/4", 5/16", 3/8"



Hard Steel Drill - Left Hand

Part #	Size	X	OAL	Shank
LHB-18	1/8"	X	3"	1/8"
LHB-20	3/16"	X	3"	3/16"
LHB-22	1/4"	X	4"	1/4"
LHB-26	5/16"	X	4"	1/4"
LHB-32	3/8"	X	6"	3/8"
LHB-50	1/2"	X	6"	1/2"



Part # LHB-SET5
5 Pc. Left Hand Hard Steel Drill Set
1/8", 3/16", 1/4", 5/16", 3/8"



Hard Steel Drill - Right Hand

Part #	Size	X	OAL	Shank
RHB-18	1/8"	X	3"	1/8"
RHB-20	3/16"	X	3"	3/16"
RHB-22	1/4"	X	4"	1/4"
RHB-26	5/16"	X	4"	1/4"
RHB-32	3/8"	X	6"	3/8"
RHB-50	1/2"	X	6"	1/2"



Part # RHB-SET5
5 Pc. Right Hand Hard Steel Drill Set
1/8", 3/16", 1/4", 5/16", 3/8"

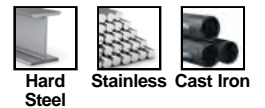

- ◆ Safes
- ◆ Broken Bolts
- ◆ Carbide Tip
- ◆ Tempered Body
- ◆ ANSI B212.15-1994
- ◆ Sold Individually



Left Hand Carbide Cut

Right Hand Carbide Cut

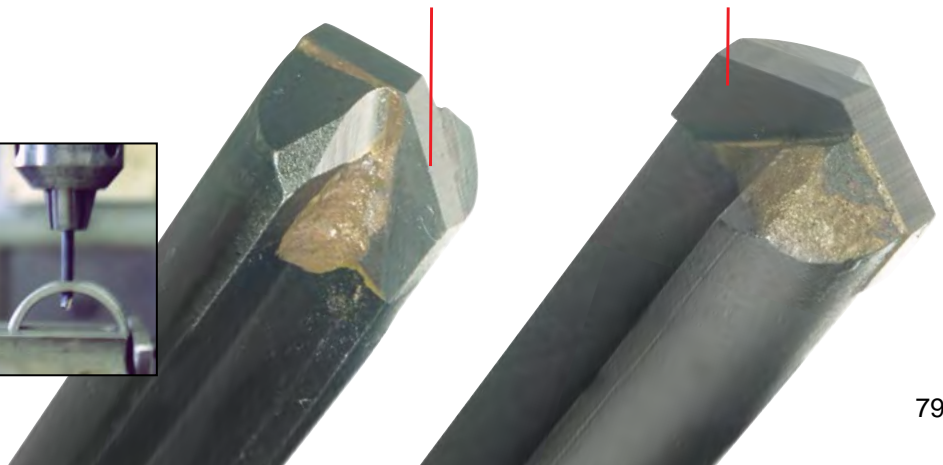
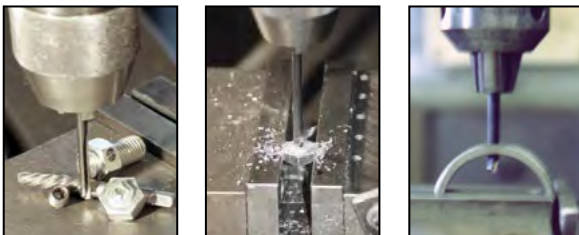



Use with Percussion



STRAIGHT SHANK



- ◆ General Purpose
- ◆ Tungsten Carbide
- ◆ Slow Spiral Flute
- ◆ Tempered Body
- ◆ Black Oxide Finish
- ◆ Gold Head
- ◆ Straight Shank
- ◆ ANSI Specification



HAMMER DRILL



SOLD INDIVIDUALLY
OR IN BULK PACKS.

Roto Percussion Drills

Part #	Size	X	OAL	Drilling	Shank	Qty.
502SP4001	1/8"	X	3"	1-1/2"	1/8"	1
502SP4001-B	1/8"	X	3"	1-1/2"	1/8"	25
502SP4002	3/16"	X	4"	2-1/2"	3/16"	1
502SP4002-B	3/16"	X	4"	2-1/2"	3/16"	25
502SP6001	3/16"	X	6"	4"	3/16"	1
502SP6001-B	3/16"	X	6"	4"	3/16"	25
502SP4732	7/32"	X	4"	2-1/2"	7/32"	1
502SP4003	1/4"	X	4"	2-1/2"	1/4"	1
502SP4003-B	1/4"	X	4"	2-1/2"	1/4"	25
502SP6002	1/4"	X	6"	4"	1/4"	1
502SP6002-B	1/4"	X	6"	4"	1/4"	25
502SP1201	1/4"	X	12"	10"	1/4"	1
502SP1814	1/4"	X	18"	16"	1/4"	1
502SP2414	1/4"	X	24"	22"	1/4"	1
502SP4004	5/16"	X	4"	2-1/2"	1/4"	1
502SP4004-B	5/16"	X	4"	2-1/2"	1/4"	25
502SP6003	5/16"	X	6"	4"	1/4"	1
502SP6003-B	5/16"	X	6"	4"	1/4"	25
502SP4005	3/8"	X	4"	2-1/2"	1/4"	1
502SP6004	3/8"	X	6"	4"	3/8"	1
502SP6004-B	3/8"	X	6"	4"	3/8"	25
502SP1203	3/8"	X	12"	10"	3/8"	1
502SP1838	3/8"	X	18"	16"	3/8"	1
502SP2438	3/8"	X	24"	22"	3/8"	1
502SP6005	7/16"	X	6"	4"	1/4"	1
502SP4006	1/2"	X	4"	2-1/2"	1/4"	1
502SP6007	1/2"	X	6"	4"	3/8"	1
502SP6007-B	1/2"	X	6"	4"	3/8"	25
502SP1204	1/2"	X	12"	10"	3/8"	1
502SP1812	1/2"	X	18"	16"	3/8"	1
502SP2412	1/2"	X	24"	22"	3/8"	1
502SP6008	9/16"	X	6"	4"	3/8"	1
502SP6009	5/8"	X	6"	4"	3/8"	1
502SP1205	5/8"	X	12"	10"	3/8"	1
502SP1858	5/8"	X	18"	16"	3/8"	1
502SP2458	5/8"	X	24"	22"	3/8"	1
502SP6010	3/4"	X	6"	4"	1/2"	1
502SP1206	3/4"	X	12"	10"	1/2"	1
502SP1834	3/4"	X	18"	16"	1/2"	1
502SP2434	3/4"	X	24"	22"	1/2"	1
502SP6011	7/8"	X	6"	4"	1/2"	1
502SP1207	7/8"	X	12"	10"	1/2"	1
502SP1878	7/8"	X	18"	16"	1/2"	1
502SP6012	1"	X	6"	4"	1/2"	1
502SP1208	1"	X	12"	10"	1/2"	1
502SP1801	1"	X	18"	16"	1/2"	1

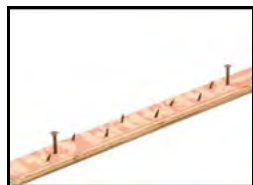

- ◆ Carbide Tip
- ◆ Bright Finish
- ◆ For Tack Strip



1/2" DRILL



Carpet Stub Drills

Part #	Size	OAL	Qty.
CD-18	1/8"	1-7/8"	1
CD-18L	1/8"	2-3/4"	1

REDLINE

2 - CUTTER

SDS-PLUS Rotary Hammer Drills

Part #	Size	X	OAL	Drilling	Qty.
RL-41064	5/32"	X	4-1/4"	2"	1
RL-61064	5/32"	X	6-1/4"	4"	1
RL-61064-B	5/32"	X	6-1/4"	4"	25
RL-41264	3/16"	X	4-1/4"	2"	1
RL-61264	3/16"	X	6-1/4"	4"	1
RL-61264-B	3/16"	X	6-1/4"	4"	25
RL-81264	3/16"	X	8-1/4"	6"	1
RL-81264-B	3/16"	X	8-1/4"	6"	25
RL-10316	3/16"	X	10-1/4"	8"	1
RL-10316-B	3/16"	X	10-1/4"	8"	25
RL-61464	7/32"	X	6-1/4"	4"	1
RL-61464-B	7/32"	X	6-1/4"	4"	25
RL-81464	7/32"	X	8-1/4"	6"	1
RL-81464-B	7/32"	X	8-1/4"	6"	25
RL-10732	7/32"	X	10-1/4"	8"	1
RL-10732-B	7/32"	X	10-1/4"	8"	25
RL-41664	1/4"	X	4-1/4"	2"	1
RL-41664-B	1/4"	X	4-1/4"	2"	25
RL-61664	1/4"	X	6-1/4"	4"	1
RL-61664-B	1/4"	X	6-1/4"	4"	25
RL-81664	1/4"	X	8-1/4"	6"	1
RL-81664-B	1/4"	X	8-1/4"	6"	25
RL-12014	1/4"	X	12-1/4"	10"	1
RL-12014-B	1/4"	X	12-1/4"	10"	25
RL-62064	5/16"	X	6-1/4"	4"	1
RL-62064-B	5/16"	X	6-1/4"	4"	25
RL-62464	3/8"	X	6-1/4"	4"	1
RL-62464-B	3/8"	X	6-1/4"	4"	25
RL-12038	3/8"	X	12-1/4"	10"	1
RL-12038-B	3/8"	X	12-1/4"	10"	20
RL-18038	3/8"	X	18"	16"	1
RL-18038-B	3/8"	X	18"	16"	20
RL-24038	3/8"	X	24"	22"	1
RL-24038-B	3/8"	X	24"	22"	20
RL-63264	1/2"	X	6-1/4"	4"	1
RL-63264-B	1/2"	X	6-1/4"	4"	25
RL-12012	1/2"	X	12-1/4"	10"	1
RL-12012-B	1/2"	X	12-1/4"	10"	10
RL-63664	9/16"	X	6-1/4"	4"	1
RL-64064	5/8"	X	6-1/4"	6"	1
RL-64064-B	5/8"	X	6-1/4"	6"	10
RL-84064	5/8"	X	8-1/4"	6"	1
RL-84064-B	5/8"	X	8-1/4"	6"	10
RL-12058	5/8"	X	12"	10"	1
RL-12058-B	5/8"	X	12"	10"	10
RL-84864	3/4"	X	8"	6"	1
RL-84864-B	3/4"	X	8"	6"	10
RL-12034	3/4"	X	12"	10"	1
RL-12034-B	3/4"	X	12"	10"	5
RL-85664	7/8"	X	8"	6"	1
RL-85664-B	7/8"	X	8"	6"	5
RL-12078	7/8"	X	12"	10"	1
RL-12078-B	7/8"	X	12"	10"	5
RL-10001	1"	X	10"	8"	1
RL-10001-B	1"	X	10"	8"	5



- ◆ Rotary Hammer Drill
- ◆ 2-Cutter Carbide Head
- ◆ ANSI Specification

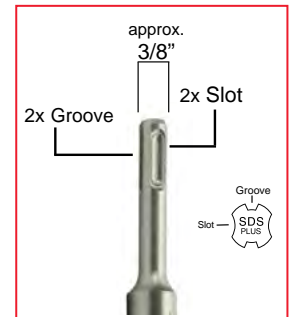



BOHR HAMMER

SDS-PLUS Rotary Hammer Drills



- ◆ Rotary Hammer Drill
- ◆ ANSI Specification
- ◆ Special Tungsten Carbide Tip
- ◆ Self Centering Chisel Point
- ◆ Fast Drilling Speed
- ◆ Clean Round Holes
- ◆ Industrial Quality



Part #	Size	X	OAL	Drilling	Head	Qty.
715S41064	5/32"	X	4-1/4"	2"	4-PLUS	1
715S61064	5/32"	X	6-1/4"	4"	4-PLUS	1
715S61064-B	5/32"	X	6-1/4"	4"	4-PLUS	25
715S41264	3/16"	X	4-1/4"	2"	4-PLUS	1
715S41264-B	3/16"	X	4-1/4"	2"	4-PLUS	25
715S61264	3/16"	X	6-1/4"	4"	4-PLUS	1
715S61264-B	3/16"	X	6-1/4"	4"	4-PLUS	25
715S81264	3/16"	X	8-1/4"	6"	4-PLUS	1
715S81264-B	3/16"	X	8-1/4"	6"	4-PLUS	25
715S10316	3/16"	X	10-1/4"	8"	4-PLUS	1
715S12316	3/16"	X	12-1/4"	10"	4-PLUS	1
715S14316	3/16"	X	14"	12"	4-PLUS	1
715S16316	3/16"	X	16"	14"	4-PLUS	1
715S20316	3/16"	X	20"	18"	4-PLUS	1
715S24316	3/16"	X	24"	22"	4-PLUS	1
715S41464	7/32"	X	4-1/4"	2"	4-PLUS	1
715S61464	7/32"	X	6-1/4"	4"	4-PLUS	1
715S81464	7/32"	X	8-1/4"	6"	4-PLUS	1
715S10732	7/32"	X	10-1/4"	8"	4-PLUS	1
715S14732	7/32"	X	14"	12"	4-PLUS	1
715S16732	7/32"	X	16"	14"	4-PLUS	1
715S20732	7/32"	X	20"	18"	4-PLUS	1
715S24732	7/32"	X	24"	22"	4-PLUS	1
715S41664	1/4"	X	4-1/4"	2"	4-PLUS	1
715S41664-B	1/4"	X	4-1/4"	2"	4-PLUS	25
715S61664	1/4"	X	6-1/4"	4"	4-PLUS	1
715S61664-B	1/4"	X	6-1/4"	4"	4-PLUS	25
715S81664	1/4"	X	8-1/4"	6"	4-PLUS	1
715S81664-B	1/4"	X	8-1/4"	6"	4-PLUS	25
715S10014	1/4"	X	10-1/4"	8"	4-PLUS	1
715S14014	1/4"	X	14"	12"	4-PLUS	1
715S16014	1/4"	X	16"	14"	4-PLUS	1
715S20014	1/4"	X	20"	18"	4-PLUS	1
715S24014	1/4"	X	24"	22"	4-PLUS	1
715S62064	5/16"	X	6-1/4"	4"	4-PLUS	1
715S62064-B	5/16"	X	6-1/4"	4"	4-PLUS	25
715S82064	5/16"	X	8-1/4"	6"	4-PLUS	1
715S12516	5/16"	X	12-1/4"	10"	4-PLUS	1
715S62464	3/8"	X	6-1/4"	4"	4-PLUS	1
715S62464-B	3/8"	X	6-1/4"	4"	4-PLUS	25
715S82464	3/8"	X	8-1/4"	6"	4-PLUS	1
715S10038	3/8"	X	10-1/4"	8"	4-PLUS	1
715S12038	3/8"	X	12-1/4"	10"	4-PLUS	1
715S12038-B	3/8"	X	12-1/4"	10"	4-PLUS	10
715S18038	3/8"	X	18"	16"	4-PLUS	1
715S24038	3/8"	X	24"	22"	4-PLUS	1
715S62864	7/16"	X	6-1/4"	4"	4-PLUS	1
715S12716	7/16"	X	12-1/4"	10"	4-PLUS	1

BOHR HAMMER

SDS-PLUS Rotary Hammer Drills

Part #	Size	X	OAL	Drilling	Head	Qty.
715S63264	1/2"	X	6-1/4"	4"	4-PLUS	1
715S63264-B	1/2"	X	6-1/4"	4"	4-PLUS	25
715S10012	1/2"	X	10-1/4"	8"	4-PLUS	1
715S12012	1/2"	X	12-1/4"	10"	4-PLUS	1
715S12012-B	1/2"	X	12-1/4"	10"	4-PLUS	10
715S12018	1/2"	X	18"	16"	4-PLUS	1
715S12024	1/2"	X	24"	22"	4-PLUS	1
715S63664	9/16"	X	6-1/4"	4"	4-PLUS	1
715S10916	9/16"	X	10-1/4"	8"	4-PLUS	1
715S12916	9/16"	X	12-1/4"	10"	4-PLUS	1
715S18916	9/16"	X	18"	16"	4-PLUS	1
715S64064	5/8"	X	6-1/4"	4"	4-PLUS	1
715S84064	5/8"	X	8-1/4"	6"	4-PLUS	1
715S84064-B	5/8"	X	8-1/4"	6"	4-PLUS	10
715S12058	5/8"	X	12-1/4"	10"	4-PLUS	1
715S18058	5/8"	X	18"	16"	4-PLUS	1
715S24058	5/8"	X	24"	22"	4-PLUS	1
715S14464	11/16"	X	12"	10"	4-PLUS	1
715S84864	3/4"	X	8"	6"	4-PLUS	1
715S84864-B	3/4"	X	8"	6"	4-PLUS	10
715S10034	3/4"	X	10"	8"	4-PLUS	1
715S12034	3/4"	X	12"	10"	4-PLUS	1
715S12034-B	3/4"	X	12"	10"	4-PLUS	5
715S18034	3/4"	X	18"	16"	4-PLUS	1
715S24034	3/4"	X	24"	22"	4-PLUS	1
715S85664	7/8"	X	8"	6"	4-PLUS	1
715S85664-B	7/8"	X	8"	6"	4-PLUS	5
715S10078	7/8"	X	10"	8"	4-PLUS	1
715S12078	7/8"	X	12"	10"	4-PLUS	1
715S12078-B	7/8"	X	12"	10"	4-PLUS	5
715S18078	7/8"	X	18"	16"	4-PLUS	1
715S86464	1"	X	8"	6"	4-PLUS	1
715S10001	1"	X	10"	8"	4-PLUS	1
715S10001-B	1"	X	10"	8"	4-PLUS	5
715S12001	1"	X	12"	10"	4-PLUS	1
715S18001	1"	X	18"	16"	4-PLUS	1

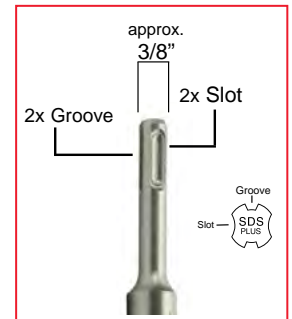

SDS-PLUS Rotary Hammer - Extra Long

Part #	Size	X	OAL	Drilling	Head	Qty.
715FL3614	1/4"	X	36"	34"	4-PLUS	1
715FL3638	3/8"	X	36"	34"	4-PLUS	1
715FL3632	1/2"	X	36"	34"	4-PLUS	1
715FL3658	5/8"	X	36"	34"	4-PLUS	1
715FL3634	3/4"	X	36"	34"	4-PLUS	1





INTERNATIONAL TOOL MANUFACTURING

150 Express St. Plainview, NY 11803

(516) 738-0388 • (800) 247-5696

ITM® Fax (516) 279-1106

BOHR HAMMER - BULK DRILLS

SDS-PLUS Rotary Hammer Drills



Concrete



Stone



Brick



Masonry

- ◆ Rotary Hammer Drill
- ◆ ANSI Specification
- ◆ Special Tungsten Carbide Tip
- ◆ Self Centering Chisel Point
- ◆ Fast Drilling Speed
- ◆ Clean Round Holes
- ◆ Industrial Quality

Part #	Size	X	OAL	Drilling	Pack	Min.Qty.
715B41064	5/32"	X	4-1/4"	2"	BULK	50
715B61064	5/32"	X	6-1/4"	4"	BULK	50
715B41264	3/16"	X	4-1/4"	2"	BULK	50
715B61264	3/16"	X	6-1/4"	4"	BULK	100
715B81264	3/16"	X	8-1/4"	6"	BULK	50
715B10316	3/16"	X	10-1/4"	8"	BULK	25
715B12316	3/16"	X	12-1/4"	10"	BULK	25
715B14316	3/16"	X	14"	12"	BULK	25
715B16316	3/16"	X	16"	14"	BULK	25
715B20316	3/16"	X	20"	18"	BULK	25
715B24316	3/16"	X	24"	22"	BULK	25
715B41464	7/32"	X	4-1/4"	2"	BULK	50
715B61464	7/32"	X	6-1/4"	4"	BULK	50
715B81464	7/32"	X	8-1/4"	6"	BULK	50
715B10732	7/32"	X	10-1/4"	8"	BULK	25
715B14732	7/32"	X	14"	12"	BULK	25
715B16732	7/32"	X	16"	14"	BULK	25
715B20732	7/32"	X	20"	18"	BULK	25
715B24732	7/32"	X	24"	22"	BULK	25



FACTORY BULK

BOHR HAMMER - BULK DRILLS

SDS-PLUS Rotary Hammer Drills

Part #	Size	X	OAL	Drilling	Pack	Min.Qty.
715B41664	1/4"	X	4-1/4"	2"	BULK	50
715B61664	1/4"	X	6-1/4"	4"	BULK	100
715B81664	1/4"	X	8-1/4"	6"	BULK	50
715B10014	1/4"	X	10-1/4"	8"	BULK	50
715B14014	1/4"	X	14"	12"	BULK	25
715B16014	1/4"	X	16"	14"	BULK	25
715B20014	1/4"	X	20"	18"	BULK	25
715B24014	1/4"	X	24"	22"	BULK	25
715B62064	5/16"	X	6-1/4"	4"	BULK	50
715B82064	5/16"	X	8-1/4"	6"	BULK	25
715B12516	5/16"	X	12-1/4"	10"	BULK	25
715B62464	3/8"	X	6-1/4"	4"	BULK	100
715B82464	3/8"	X	8-1/4"	6"	BULK	50
715B10038	3/8"	X	10-1/4"	8"	BULK	25
715B12038	3/8"	X	12-1/4"	10"	BULK	25
715B18038	3/8"	X	18"	16"	BULK	25
715B24038	3/8"	X	24"	22"	BULK	25
715B63264	1/2"	X	6-1/4"	4"	BULK	100
715B10012	1/2"	X	10-1/4"	8"	BULK	25
715B12012	1/2"	X	12-1/4"	10"	BULK	25
715B12018	1/2"	X	18"	16"	BULK	25
715B12024	1/2"	X	24"	22"	BULK	25



Concrete

Stone

Brick

Masonry

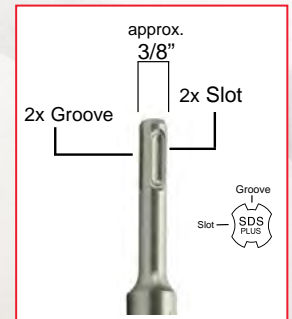

FACTORY BULK



XCUTTER

DRILLS REINFORCED CONCRETE!

SDS-PLUS Rotary Hammer Drills

Part #	Size	X	OAL	Drilling	Head	Qty.
EVL41264	3/16"	X	4-1/2"	2"	X-CUTTER	1
EVL41264-B	3/16"	X	4-1/2"	2"	X-CUTTER	25
EVL61264	3/16"	X	6-1/2"	4"	X-CUTTER	1
EVL61264-B	3/16"	X	6-1/2"	4"	X-CUTTER	25
EVL81264	3/16"	X	8-1/2"	6"	X-CUTTER	1
EVL81264-B	3/16"	X	8-1/2"	6"	X-CUTTER	25
EVL10316	3/16"	X	10-1/2"	8"	X-CUTTER	1
EVL12316	3/16"	X	12-1/2"	10"	X-CUTTER	1
EVL41664	1/4"	X	4-1/2"	2"	X-CUTTER	1
EVL41664-B	1/4"	X	4-1/2"	2"	X-CUTTER	25
EVL61664	1/4"	X	6-1/2"	4"	X-CUTTER	1
EVL61664-B	1/4"	X	6-1/2"	4"	X-CUTTER	25
EVL81664	1/4"	X	8-1/2"	6"	X-CUTTER	1
EVL81664-B	1/4"	X	8-1/2"	6"	X-CUTTER	25
EVL10014	1/4"	X	10-1/2"	8"	X-CUTTER	1
EVL12014	1/4"	X	12-1/2"	10"	X-CUTTER	1
EVL62064	5/16"	X	6-1/2"	4"	X-CUTTER	1
EVL62064-B	5/16"	X	6-1/2"	4"	X-CUTTER	25
EVL12516	5/16"	X	12-1/2"	10"	X-CUTTER	1
EVL18516	5/16"	X	18"	16"	X-CUTTER	1
EVL62464	3/8"	X	6-1/4"	4"	X-CUTTER	1
EVL62464-B	3/8"	X	6-1/4"	4"	X-CUTTER	25
EVL12038	3/8"	X	12-1/4"	10"	X-CUTTER	1
EVL18038	3/8"	X	18"	16"	X-CUTTER	1
EVL62864	7/16"	X	6-1/4"	4"	X-CUTTER	1
EVL12716	7/16"	X	12-1/4"	10"	X-CUTTER	1
EVL18716	7/16"	X	18"	16"	X-CUTTER	1
EVL63264	1/2"	X	6-1/4"	4"	X-CUTTER	1
EVL63264-B	1/2"	X	6-1/4"	4"	X-CUTTER	25
EVL12012	1/2"	X	12-1/4"	10"	X-CUTTER	1
EVL18012	1/2"	X	18"	16"	X-CUTTER	1



- ◆ Rotary Hammer Drill
- ◆ ANSI Specification
- ◆ Welded 1 Pc. Solid Carbide Head up to 1-1/8"
- ◆ Rebar Chamfers
- ◆ Optimized Core Ensures Impact Durability and Rotational Stability
- ◆ High Break Resistance
- ◆ Drills Reinforced Concrete

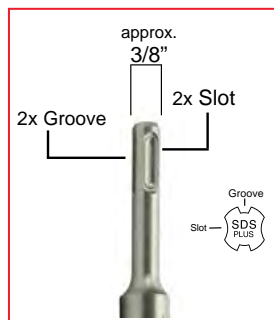

XCUTTER

DRILLS REINFORCED CONCRETE!

x 1 Pc. Monoblock Solid Carbide
X CUTTER Head - 3/16" - 1-1/8"

x 3 Pc. Carbide
X CUTTER Head - 1-1/4" - 2"

X-CUTTER *DRILLS REINFORCED CONCRETE!*



SDS-PLUS Rotary Hammer Drills

Part #	Size	X	OAL	Drilling	Head
EVL63664	9/16"	X	6-1/4"	4"	X-CUTTER
EVL12916	9/16"	X	12-1/4"	10"	X-CUTTER
EVL18916	9/16"	X	18"	16"	X-CUTTER
EVL84064	5/8"	X	8-1/4"	6"	X-CUTTER
EVL10058	5/8"	X	10-1/4"	8"	X-CUTTER
EVL12058	5/8"	X	12-1/4"	10"	X-CUTTER
EVL18058	5/8"	X	18"	16"	X-CUTTER
EVL84864	3/4"	X	8"	6"	X-CUTTER
EVL10034	3/4"	X	10"	8"	X-CUTTER
EVL12034	3/4"	X	12"	10"	X-CUTTER
EVL18034	3/4"	X	18"	16"	X-CUTTER
EVL85664	7/8"	X	8"	6"	X-CUTTER
EVL10078	7/8"	X	10"	8"	X-CUTTER
EVL12078	7/8"	X	12"	10"	X-CUTTER
EVL18078	7/8"	X	18"	16"	X-CUTTER
EVL10001	1"	X	10"	8"	X-CUTTER
EVL12001	1"	X	12"	10"	X-CUTTER
EVL18001	1"	X	18"	16"	X-CUTTER
EVL10118	1-1/8"	X	10"	8"	X-CUTTER
EVL18118	1-1/8"	X	18"	16"	X-CUTTER
EVL18114	1-1/4"	X	18"	16"	X-CUTTER



SDS-PLUS Rotary Hammer - **Extra Long**

Part #	Size	X	OAL	Drilling	Head
EVL40038	3/8"	X	40"	38"	X-CUTTER
EVL40012	1/2"	X	40"	38"	X-CUTTER
EVL40058	5/8"	X	40"	38"	X-CUTTER
EVL40034	3/4"	X	40"	38"	X-CUTTER

NOW 40" LONG. 38" OF DRILLING DEPTH.

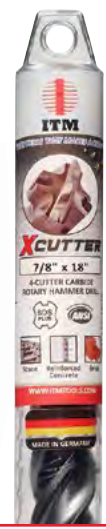
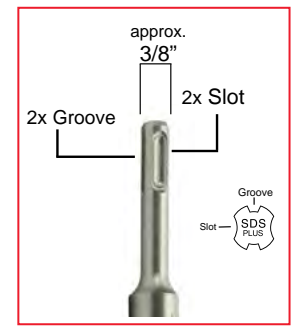
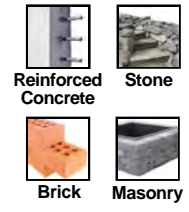

**SOLD INDIVIDUALLY
1 PER TUBE.**





INTERNATIONAL TOOL MANUFACTURING
150 Express St. Plainview, NY 11803

(516) 738-0388 • (800) 247-5696

ITM® Fax (516) 279-1106

X-CUTTER DRILLS REINFORCED CONCRETE!

SDS-MAX® Rotary Hammer Drills



- ◆ Rotary Hammer Drill
- ◆ ANSI Specification
- ◆ Welded 1 Pc. Solid Carbide Head up to 1-1/8"
- ◆ Rebar Chamfers
- ◆ Optimized Core Ensures Impact Durability and Rotational Stability
- ◆ High Break Resistance
- ◆ Drills Reinforced Concrete



Part #	Size	X	OAL	Drilling	Head
SMTE1338	3/8"	X	13"	8"	X-CUTTER
SMTE1312	1/2"	X	13"	8"	X-CUTTER
SMTE1712	1/2"	X	17"	12"	X-CUTTER
SMTE2212	1/2"	X	21"	16"	X-CUTTER
SMTE1391	9/16"	X	13"	8"	X-CUTTER
SMTE2192	9/16"	X	21"	16"	X-CUTTER
SMTE1358	5/8"	X	13"	8"	X-CUTTER
SMTE1758	5/8"	X	17"	12"	X-CUTTER
SMTE2258	5/8"	X	21"	16"	X-CUTTER
SMTE3658	5/8"	X	36"	31"	X-CUTTER
SMTE2111	11/16"	X	21"	16"	X-CUTTER
SMTE1334	3/4"	X	13"	8"	X-CUTTER
SMTE1734	3/4"	X	17"	12"	X-CUTTER
SMTE2234	3/4"	X	21"	16"	X-CUTTER
SMTE3634	3/4"	X	36"	31"	X-CUTTER
SMTE2113	13/16"	X	21"	16"	X-CUTTER
SMTE1378	7/8"	X	13"	8"	X-CUTTER
SMTE1778	7/8"	X	17"	12"	X-CUTTER
SMTE2278	7/8"	X	21"	16"	X-CUTTER
SMTE3678	7/8"	X	36"	31"	X-CUTTER
SMTE1301	1"	X	13"	8"	X-CUTTER
SMTE1701	1"	X	17"	12"	X-CUTTER
SMTE2201	1"	X	21"	16"	X-CUTTER
SMTE3601	1"	X	36"	31"	X-CUTTER
SMTE2311	1-1/16"	X	23"	18"	X-CUTTER
SMTE1718	1-1/8"	X	17"	12"	X-CUTTER
SMTE2218	1-1/8"	X	23"	18"	X-CUTTER
SMTE3618	1-1/8"	X	36"	31"	X-CUTTER
SMTE1714	1-1/4"	X	15"	10"	X-CUTTER
SMTE2214	1-1/4"	X	23"	18"	X-CUTTER
SMTE3614	1-1/4"	X	36"	31"	X-CUTTER
SMTE1738	1-3/8"	X	17"	12"	X-CUTTER
SMTE2238	1-3/8"	X	23"	18"	X-CUTTER
SMTE3638	1-3/8"	X	36"	31"	X-CUTTER
SMTE1721	1-1/2"	X	17"	12"	X-CUTTER
SMTE2221	1-1/2"	X	23"	18"	X-CUTTER
SMTE3621	1-1/2"	X	36"	31"	X-CUTTER
SMTE2334	1-3/4"	X	23"	18"	X-CUTTER
SMTE3613	1-3/4"	X	36"	31"	X-CUTTER
SMTE2202	2"	X	23"	18"	X-CUTTER



SDS-MAX® Rotary Hammer - Extra Long

Part #	Size	X	OAL	Drilling	Head
SMTE5258	5/8"	X	52"	47"	X-CUTTER
SMTE5234	3/4"	X	52"	47"	X-CUTTER
SMTE5278	7/8"	X	52"	47"	X-CUTTER
SMTE5201	1"	X	52"	47"	X-CUTTER
SMTE5214	1-1/4"	X	52"	47"	X-CUTTER
SMTE5238	1-3/8"	X	52"	47"	X-CUTTER
SMTE5212	1-1/2"	X	52"	47"	X-CUTTER



SOLD INDIVIDUALLY
1 PER TUBE.

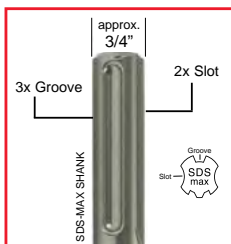

Bosch® License

FREIGHT CHARGES ON THESE 52" LONG SDS-MAX BITS WILL NOT BE PREPAID.

X-Tend Your Drilling Depths!



X-Tendr™ - MAX to MAX SHANK ADAPTER

Part #	Description
XT6700	Adapter (1-3/16" x 7-1/2")
XT6750	Adapter Grease (Tube)

Drill Bit Diameter Must Be 1-1/4" Or Larger if X-Tendr™ is to Pass Through Hole Being Drilled.

Drill bit extension system for all SDS-MAX machines.

- ◆ X-Tend Any SDS-MAX® Tool
- ◆ Quick & Safe Connection
- ◆ Simple To Use
- ◆ No Energy Loss
- ◆ No Weak Points
- ◆ Saves Time & Money
- ◆ Reduces Tool Requirements
- ◆ Sold Individually

How it works:

- X-Tendr™ Adapter has double locking SDS-MAX inputs.
- All EXTENSION SHAFTS have 1 SDS-MAX® end which locks into X-Tendr™ Adapter. Other end can be inserted into an SDS-MAX® machine.
- X-Tend any SDS-MAX® drill bit, core bit, tunnel bore drill.
- Reach of X-Tendr™ system limited to 1 adapter and 1 extension.



SDS-MAX® Shaft

X-Tendr™ Extension Shafts

Part #	OAL	Shank
XT6701	12-1/2"	SDS-MAX
XT6702	30"	SDS-MAX
XT6703	44"	SDS-MAX
XT6704	82-1/2"	SDS-MAX



1. Choose SDS-MAX® desired length Extension.



2. Attach X-Tendr™ Adapter to SDS-MAX® end of Extension.



3. Attach desired SDS-MAX® Rotary Hammer Drill Bit, Core Bit, Tunnel Bore Drill.

Drill Bit Diameter Must Be 1-1/4" Or Larger if X-Tendr™ is to Pass Through Hole Being Drilled.

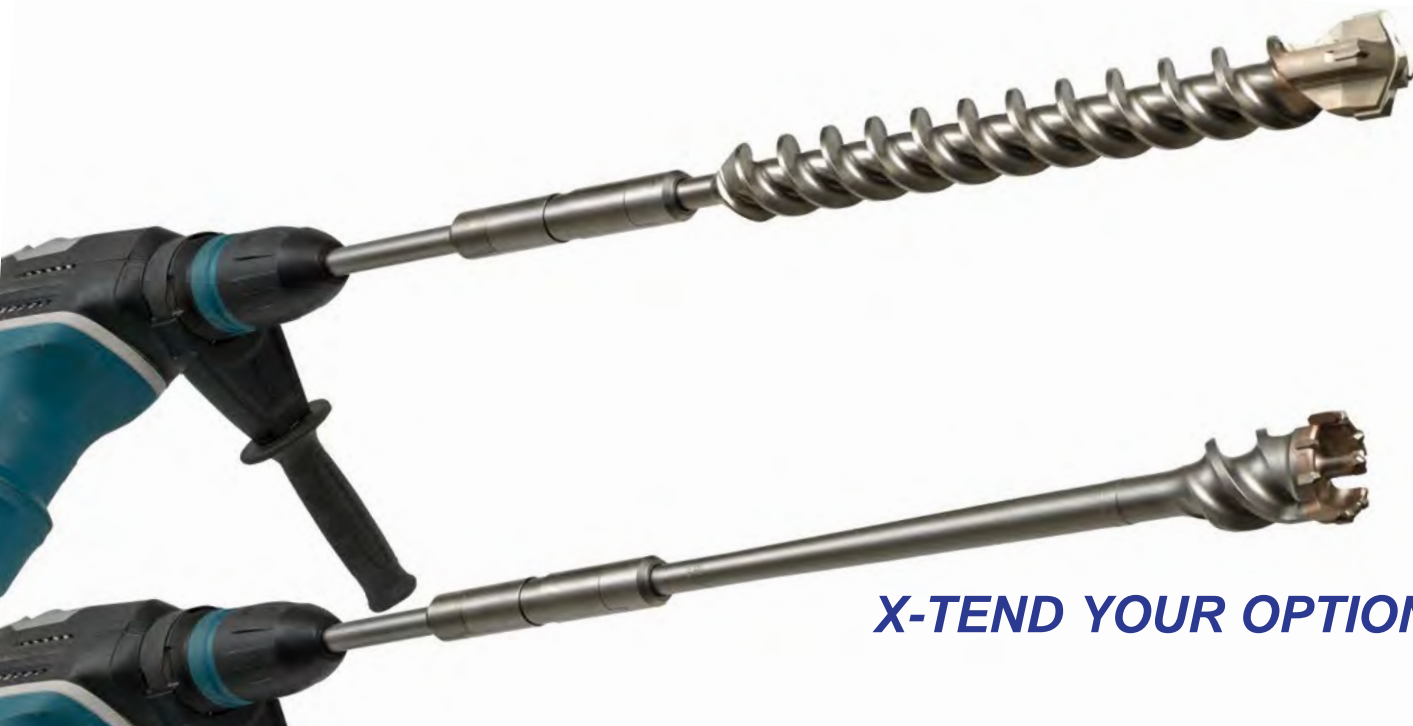

X-TEND YOUR OPTIONS...



TAPER SYSTEM



- ◆ Taper System
- ◆ Interchangeable & Versatile
- ◆ Special Tungsten Carbide Tip
- ◆ Copper / Silver Brazing
- ◆ Smooth Body For Less Vibration
- ◆ Clean Round Holes
- ◆ Industrial Quality
- ◆ 3" Cutting Depth Before Core Removal
- ◆ Parts Sold Individually



SOLD INDIVIDUALLY
1 PER TUBE.

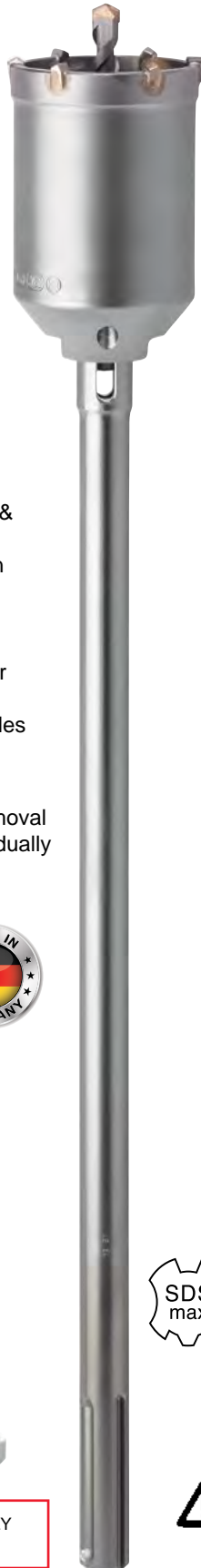

TAPER



Pilot Drill - A-TAPER FOR EXTENSION

Part #	Size
721PD0385	3/8" X 5" PILOT DRILL



Ejector Key

Part #	Description
722EJ0001	EJECTOR KEY



Carbide Core Bit - 4" OAL / TAPER

Part #	Size	# Teeth
719CB0050	2"	6
719CB0065	2-3/4"	6
719CB0080	3" (3-1/8")	8
719CB0090	3-1/2" (3-9/16")	8
719CB0100	4"	10
719CB0125	5"	12



SDS-MAX® Taper Shanks

Part #	Size	Shank
720MAX008	8"	SDS-MAX
720MAX018	18"	SDS-MAX

INSTRUCTIONS

- 1 Wipe off oil or lubricant from the taper of the extension and the inner taper of the core bit.
- 2 Insert the pilot drill into the drive extension first.
- 3 Insert the drive extension into the core bit.
- 4 Start drilling hole until the core bit is 3/8" deep.
- 5 Use the ejector key to push out the pilot drill.
- 6 Continue drilling the hole until the material being drilled fills the core bit interior. Approximately 3" deep.
- 7 Break the drilled material inside the core bit with a chisel (if necessary.)
- 8 Return to Step 6 until desired hole depth is achieved.

These Heavy Duty Rotary Hammer Core Bits are used with SDS-MAX electric rotary hammer machines. The special alloy steel body and Tungsten Carbide withstand continuous hammering. A pilot drill bit and extension are required.



Notice: Core Bit drilling without the use of a pilot drill bit causes excessive pressure on the taper shank system. This can result in breakage to the extension at the tapered end, especially between the two slots. Such jagged breaks are not considered defective and may not be covered under warranty.



Each Core Bit
Includes Pilot Drill

Pilot Drill - THREADED REPLACEMENT DRILL

Part #	Size
880PD1143	1/2" X 5" PILOT DRILL (Threaded)



- ◆ Special Tungsten Carbide Tip
- ◆ Copper / Silver Brazing
- ◆ Smooth Body For Less Vibration
- ◆ Clean Round Holes
- ◆ Industrial Quality
- ◆ 3" Cutting Depth Before Core Removal
- ◆ 1/2" x 6" Pilot Included



1-Pc SDS-MAX® Core Bits

Part #	Size	X	OAL	# Teeth	Shank
880SL1035	2"	X	12"	6	SDS-MAX
880SL1045	2"	X	22"	6	SDS-MAX
880SL1055	2-3/4"	X	12"	6	SDS-MAX
880SL1065	2-3/4"	X	22"	6	SDS-MAX
880SL1075	3-1/4"	X	12"	8	SDS-MAX
880SL1085	3-1/4"	X	22"	8	SDS-MAX
880SL1095	3-1/2"	X	12"	8	SDS-MAX
880SL1105	3-1/2"	X	22"	8	SDS-MAX
880SL1115	4"	X	12"	10	SDS-MAX
880SL1125	4"	X	22"	10	SDS-MAX
880SL1135	5"	X	22"	12	SDS-MAX
880SL1145	6"	X	22"	14	SDS-MAX

SDS-MAX® Tunnel Bore Drills

Part #	Size	X	OAL	Shank
950CC7333	1-3/4"	X	22"	SDS-MAX
950CC7342	1-3/4"	X	39"	SDS-MAX
950CC7337	2-1/8"	X	22"	SDS-MAX
950CC7343	2-1/8"	X	39"	SDS-MAX
950CC7339	2-1/2"	X	22"	SDS-MAX
950CC7344	2-1/2"	X	39"	SDS-MAX
950CC7341	3-1/8"	X	22"	SDS-MAX
950CC7345	3-1/8"	X	39"	SDS-MAX

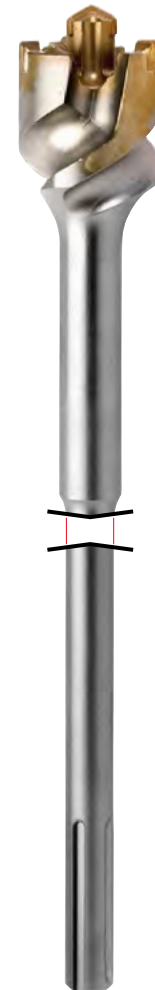

- ◆ 1 Piece Construction
- ◆ Fixed Centering Point
- ◆ Special Tungsten Carbide Tip
- ◆ Copper / Silver Brazing
- ◆ Clean Round Holes
- ◆ Fast Continuous Drilling
- ◆ Industrial Quality



SOLD INDIVIDUALLY
1 PER TUBE.



Extensions on Page 89.

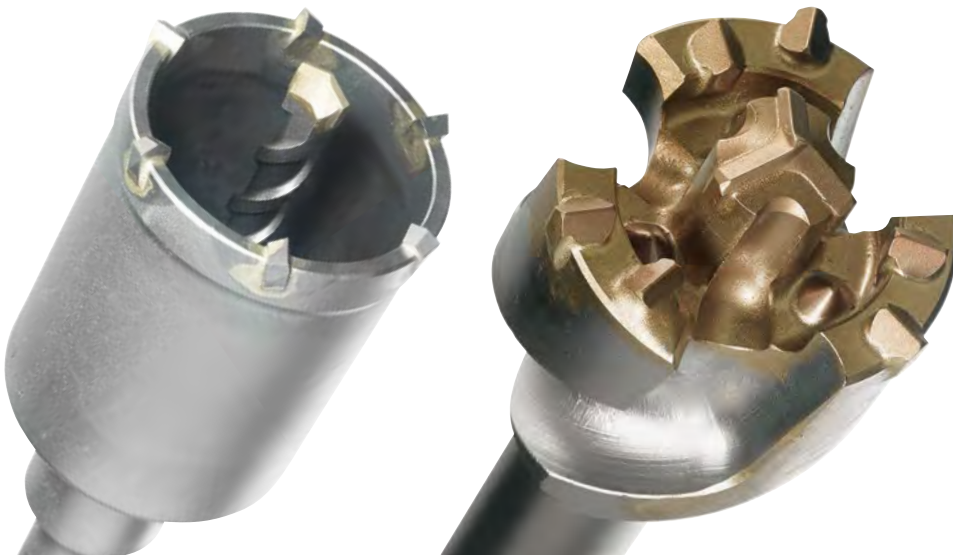



INTERNATIONAL TOOL MANUFACTURING
150 Express St. Plainview, NY 11803

(516) 738-0388 • (800) 247-5696

ITM® Fax (516) 279-1106



Concrete



Stone



Brick



Masonry

- ◆ Modular System
- ◆ Up to 6" Diameter
- ◆ Adapters Accommodate Any Combination
- ◆ Unmatched Flexibility
- ◆ Sold Individually



SOLD INDIVIDUALLY
1 PER TUBE.



RATIO
SYSTEM



SDS-MAX® Extension and Pilot Bit

Part #	Size
800RP255	CARBIDE PILOT BIT (1/2" x 6")
800RA020	SDS-MAX ADAPTER SHANK (7")
800RE300	11" LONG EXTENSION - NO FLUTE



Carbide Ratio Heavy Duty Core Bits

Part #	Size	Depth	Teeth	Shank
800RK200	2"	3"	6	SDS-MAX
800RK250	2-1/2"	3"	6	SDS-MAX
800RK300	3"	3"	8	SDS-MAX
800RK350	3-1/2"	3"	8	SDS-MAX
800RK400	4"	3"	10	SDS-MAX
800RK500	5"	3"	12	SDS-MAX
800RK600	6"	3"	14	SDS-MAX



Concrete



Stone



Brick



Masonry

- ◆ Industrial Quality
- ◆ Tungsten Carbide Teeth
- ◆ M16 Thread
- ◆ 2" Cutting Depth
- ◆ Use Rotary Hammer Action
- ◆ Clean Round Holes
- ◆ Each Piece Sold Individually



SDS-PLUS Extension and Pilot Bit

Part #	Size
LCB-PILOT	CARBIDE PILOT BIT (5/16" x 4-3/4")
LCB-12EX	12" SDS-PLUS EXTENSION WITH PILOT BIT
LCB-18EX	18" SDS-PLUS EXTENSION WITH PILOT BIT



Each Extension Comes
With One Pilot Bit

Carbide Lightweight Core Bits

Part #	Size	Depth	Teeth	Shank
LCB-1	1-3/16"	2"	6	SDS-PLUS
LCB-2	1-3/8"	2"	6	SDS-PLUS
LCB-3	1-1/2"	2"	6	SDS-PLUS
LCB-4	1-3/4"	2"	6	SDS-PLUS
LCB-5	2"	2"	6	SDS-PLUS
LCB-6	2-1/2"	2"	6	SDS-PLUS
LCB-7	3-1/8"	2"	6	SDS-PLUS
LCB-8	3-1/2"	2"	6	SDS-PLUS
LCB-9	4"	2"	8	SDS-PLUS



Superdry™ Center Pin

Part #	Description
DRY-CP1	CENTER PIN - FOR SUPERDRY DIAMOND

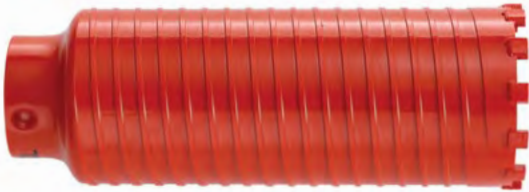

WON'T BLOW THE BACK OUT



Rotation Only!

Superdry™ Diamond Core Bit

Part #	Size	# Teeth	Drilling	Shank
DRY-25C	1"	6	6"	#1
DRY-29C	1-1/8"	7	6"	#1
DRY-32C	1-1/4"	8	6"	#1
DRY-35C	1-3/8"	8	6"	#1
DRY-38C	1-1/2"	9	6"	#1
DRY-45C	1-3/4"	9	6"	#1
DRY-50C	2"	10	6"	#2
DRY-55C	2-1/8"	11	6"	#2
DRY-60C	2-3/8"	12	6"	#2
DRY-65C	2-9/16"	12	6"	#2
DRY-70C	2-3/4"	13	6"	#2
DRY-75C	2-7/8"	15	6"	#2
DRY-80C	3-1/8"	16	6"	#2
DRY-90C	3-1/2"	16	6"	#2
DRY-95C	3-3/4"	16	6"	#2
DRY-100C	3-7/8"	17	6"	#2
DRY-105C	4-1/8"	17	6"	#2
DRY-120C	4-3/4"	17	6"	#2
DRY-130C	5-1/8"	18	6"	#2
DRY-155C	6"	22	6"	#2
DRY-165C	6-1/2"	24	6"	#2
DRY-180C	7"	25	6"	#2
DRY-210C	8-1/4"	30	6"	#2

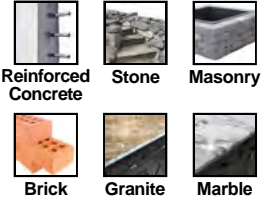

- ◆ CLIC System
- ◆ Diamond Teeth
- ◆ Capable of Dry Drilling in Reinforced Concrete
- ◆ Carbide Tipped Center Pin
- ◆ Clean Round Holes
- ◆ Made in Japan
- ◆ Each Piece Sold Individually



Superdry™ SDS-Plus Extension

Part #	Size	Shank
DRY-S1-8	5" EXTENSION (FOR 1" THRU 1-3/4")	#1
DRY-S1-12	8" EXTENSION (FOR 1" THRU 1-3/4")	#1
DRY-S2-8	5" EXTENSION (FOR 2" THRU 8-1/4")	#2
DRY-S2-12	8" EXTENSION (FOR 2" THRU 8-1/4")	#2





- ◆ Stone Countertops
- ◆ Quality Premium Diamond Teeth
- ◆ 2-1/2" Cutting Depth
- ◆ Vacuum Brazed Side Diamond
- ◆ 10mm Segments
- ◆ Sold Individually



Diamond Core Bits - Stone Countertops

Part #	Size	X	OAL	# Teeth	Thread
GRA-09	1"	X	4"	3	5/8" - 11
GRA-10	1-1/4"	X	4"	3	5/8" - 11
GRA-11	1-3/8"	X	4"	4	5/8" - 11
GRA-12	1-1/2"	X	4"	4	5/8" - 11
GRA-13	2"	X	4"	4	5/8" - 11
GRA-15	3"	X	4"	5	5/8" - 11
GRA-18	4"	X	4"	6	5/8" - 11



SDS-Plus to 5/8"-11 Adapter P. 95



- ◆ Industrial Quality
- ◆ Quality Premium Diamond Teeth
- ◆ 9" Cutting Depth
- ◆ Dry Drilling
- ◆ 10mm Segments
- ◆ Sold Individually



Diamond Core Bits - Dry Drilling

Part #	Size	X	OAL	# Teeth	Thread
DRX-02	1-1/4"	X	10-3/4"	3	5/8" - 11
DRX-03	1-1/2"	X	10-3/4"	3	5/8" - 11
DRX-04	2"	X	10-3/4"	4	5/8" - 11
DRX-05	2-1/2"	X	10-3/4"	4	5/8" - 11
DRX-07	3"	X	10-3/4"	4	5/8" - 11



FOR USE WITH A 7" ANGLE GRINDER

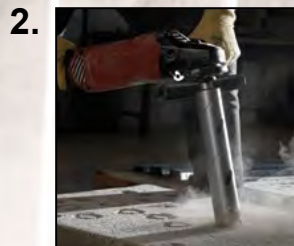

FOR DRILLING
LARGER DIAMETER
HOLES IN CONCRETE



Diamond Core Bits - Premium

Part #	Size	X	OAL	# Teeth	Thread
KDX-01	1"	X	15-3/4"	3	5/8" - 11
KDX-02	1-1/4"	X	15-3/4"	4	1-1/4" - 7
KDX-25	1-1/2"	X	15-3/4"	4	1-1/4" - 7
KDX-03	1-3/4"	X	15-3/4"	4	1-1/4" - 7
KDX-04	2"	X	15-3/4"	5	1-1/4" - 7
KDX-05	2-1/2"	X	15-3/4"	6	1-1/4" - 7
KDX-06	2-3/4"	X	15-3/4"	6	1-1/4" - 7
KDX-07	3"	X	15-3/4"	6	1-1/4" - 7
KDX-75	3-1/2"	X	15-3/4"	6	1-1/4" - 7
KDX-08	4"	X	15-3/4"	8	1-1/4" - 7
KDX-95	4-1/2"	X	15-3/4"	9	1-1/4" - 7
KDX-11	5"	X	15-3/4"	10	1-1/4" - 7
KDX-12	6"	X	15-3/4"	12	1-1/4" - 7
KDX-65	6-1/2"	X	15-3/4"	12	1-1/4" - 7
KDX-20	8"	X	15-3/4"	16	1-1/4" - 7
KDX-30	10"	X	15-3/4"	18	1-1/4" - 7
KDX-40	12"	X	15-3/4"	20	1-1/4" - 7



- ◆ Industrial Quality
- ◆ Quality Premium Diamond Teeth
- ◆ 14" Cutting Depth
- ◆ Use With Water



SOLD INDIVIDUALLY
1 PER SLEEVE.

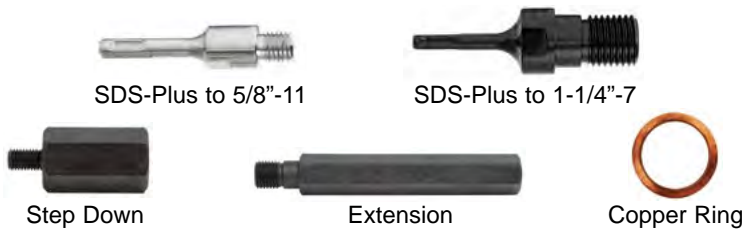
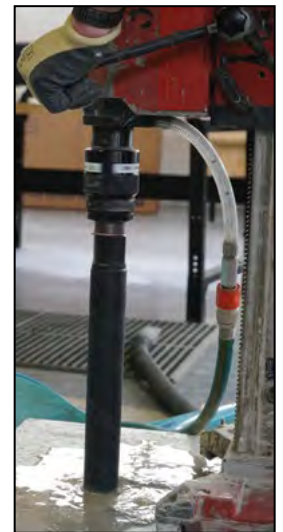

Diamond Core Adapters / Extensions

Part #	Description
ADA001	ADAPTER STEP DOWN (1-1/4"-7 TO 5/8"-11)
ADA002	SDS-PLUS TO 5/8"-11 ADAPTER
ADA003	SDS-PLUS TO 1-1/4"-7 ADAPTER
DCEXT01	6" DIAMOND CORE BIT EXTENSION (5/8"-11)
DCEXT02	12" DIAMOND CORE BIT EXTENSION (5/8"-11)
DCEXT03	6" DIAMOND CORE BIT EXTENSION (1-1/4"-7)
DCEXT04	12" DIAMOND CORE BIT EXTENSION (1-1/4"-7)
CR01	COPPER RING (FOR EASY CORE BIT REMOVAL)



Diamond Core Machine Adapters

Part #	Description
HILA001	HILTI BI+ TO 5/8"-11 ADAPTER - 100/110/120/130/150/160
HILA002	HILTI BI+ TO 1-1/4"-7 ADAPTER - 100/110/120/130/150/160
HILA003	HILTI BL TO 1-1/4"-7 ADAPTER - DD 200/250/350/500
HILA004	HILTI BU (SPLINE) TO 1-1/4"-7 ADAPTER - DD 400/750

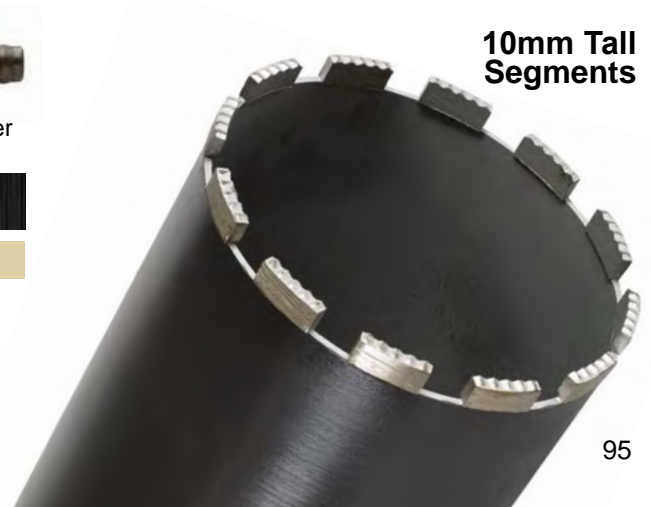



Concrete



Stone



Brick



Masonry

- ◆ Rotary Hammer Drill
- ◆ Industrial Quality
- ◆ 4-Cutter Head
- ◆ Two Large Suction Holes
- ◆ Cleaner and Faster
- ◆ Copper / Silver Brazing
- ◆ Heat Treated Body
- ◆ Clean Round Holes
- ◆ Less Vibration
- ◆ Polished Finish
- ◆ ANSI Specification



SDS-PLUS



SDS-MAX



FRANCE

SOLD INDIVIDUALLY.



SDS-Plus Duster Drill Bit

Part #	Size	X	OAL	Drilling	Head
EXS-012	1/2"	X	16"	10"	DUSTER
EXS-916	9/16"	X	16"	10"	DUSTER
EXS-058	5/8"	X	16"	10"	DUSTER
EXS-034	3/4"	X	16"	10"	DUSTER

EXS-1S PLASTIC ADAPTER SDS-PLUS REPLACEMENT



SDS-MAX® Duster Drill Bit

Part #	Size	X	OAL	Drilling	Head
EXM-120	1/2"	X	24"	16"	DUSTER
EXM-580	5/8"	X	24"	16"	DUSTER
EXM-340	3/4"	X	24"	16"	DUSTER
EXM-780	7/8"	X	24"	16"	DUSTER
EXM-100	1"	X	24"	16"	DUSTER
EXM-118	1-1/8"	X	24"	16"	DUSTER
EXM-138	1-3/8"	X	24"	16"	DUSTER

EXM-1M PLASTIC ADAPTER SDS-MAX REPLACEMENT

Suction Holes



Attach to Any HEPA Rated Vacuum to Meet OSHA Silica Dust Containment Standards.

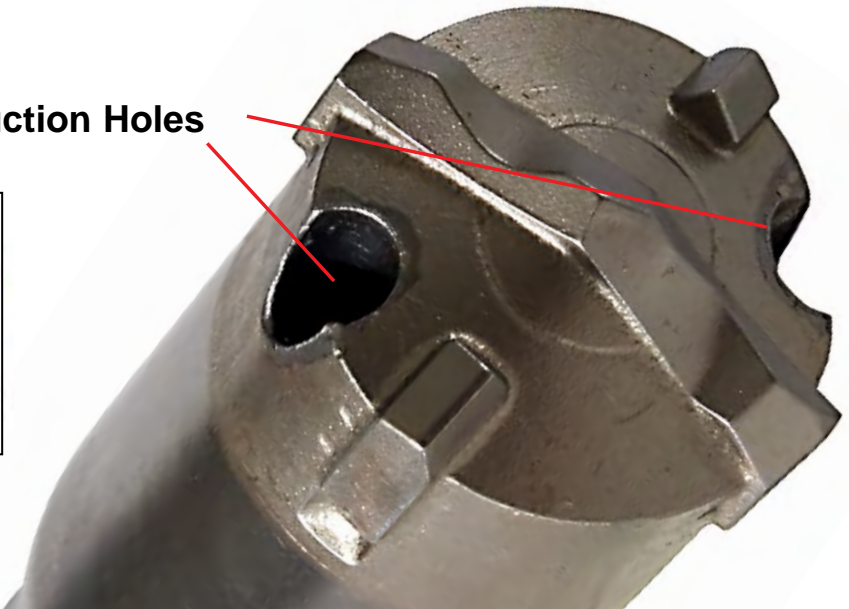



Economy Dust Pro (Up to 1")

Part #	Description	Qty.
DP-1	ECONOMY DUST PRO (PLASTIC)	1



- ◆ Attach to HEPA Vacuum and Stick to Drilling Surface
- ◆ No Drilling Dust
- ◆ No Need to Clean Holes Before Anchoring



SOLD INDIVIDUALLY.



Sold With One Metal Insert.



Small Dust Pro (Up to 1")

Part #	Description	Qty.
DP-2	SMALL DUST PRO	1



Sold With One Rubber Insert.



Large Dust Pro (Up to 3")

Part #	Description	Qty.
DP-3	LARGE DUST PRO	1



Metal Plate for DP-2



Rubber Plate for DP-3



Replacement Inserts

Part #	Description	Qty.
DP-2-PL	METAL PLATE REPLACEMENT	1
DP-3-PL	RUBBER CUT OUT REPLACEMENT	1

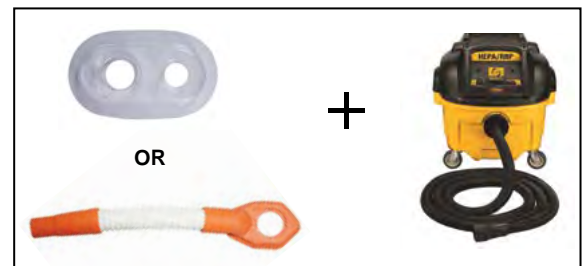

Attach to Any HEPA Rated Vacuum to Meet OSHA Silica Dust Containment Standards.



For Drop-in Anchors



Concrete



Stone



Brick



Masonry

- ◆ Rotary Hammer Drill
- ◆ STOP - Lip Prevents Over-Drilling
- ◆ Drill Exact Depth For Drop-In Anchor
- ◆ Less Likely to Hit Rebar
- ◆ ANSI Specification
- ◆ Sold Individually



SDS-PLUS + STOP Rotary Hammer Bit

Part #	Size	Drill Depth	Anchor Size	Qty.
STP-413	1/4"	11/16"	3/16"	1
STP-617	3/8"	1-1/16"	1/4"	1
STP-813	1/2"	13/16"	3/8" Short	1
STP-827	1/2"	1-11/16"	3/8"	1
STP-1019	5/8"	1-3/16"	1/2" Short	1
STP-1033	5/8"	2-1/16"	1/2"	1
STP-418	7/8"	2-5/8"	5/8"	1
STP-419	1"	3-1/4"	3/4"	1



FOR DRIVING HAMMER IN ANCHORS.



Concrete



Stone



Brick



Masonry

- ◆ Rotary Hammer Anchor Driver
- ◆ Use with Hammer In Anchors
- ◆ Drive Anchors Effortlessly
- ◆ Sold Individually

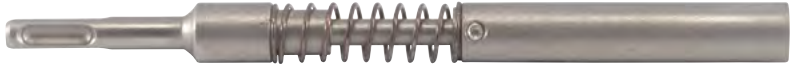

SDS-PLUS Hammer Nail-In Anchor Driver

Part #	Size	Anchor Size	Qty.
SDS-HD1	1/4" x 9"	1/4" NAIL-IN	1

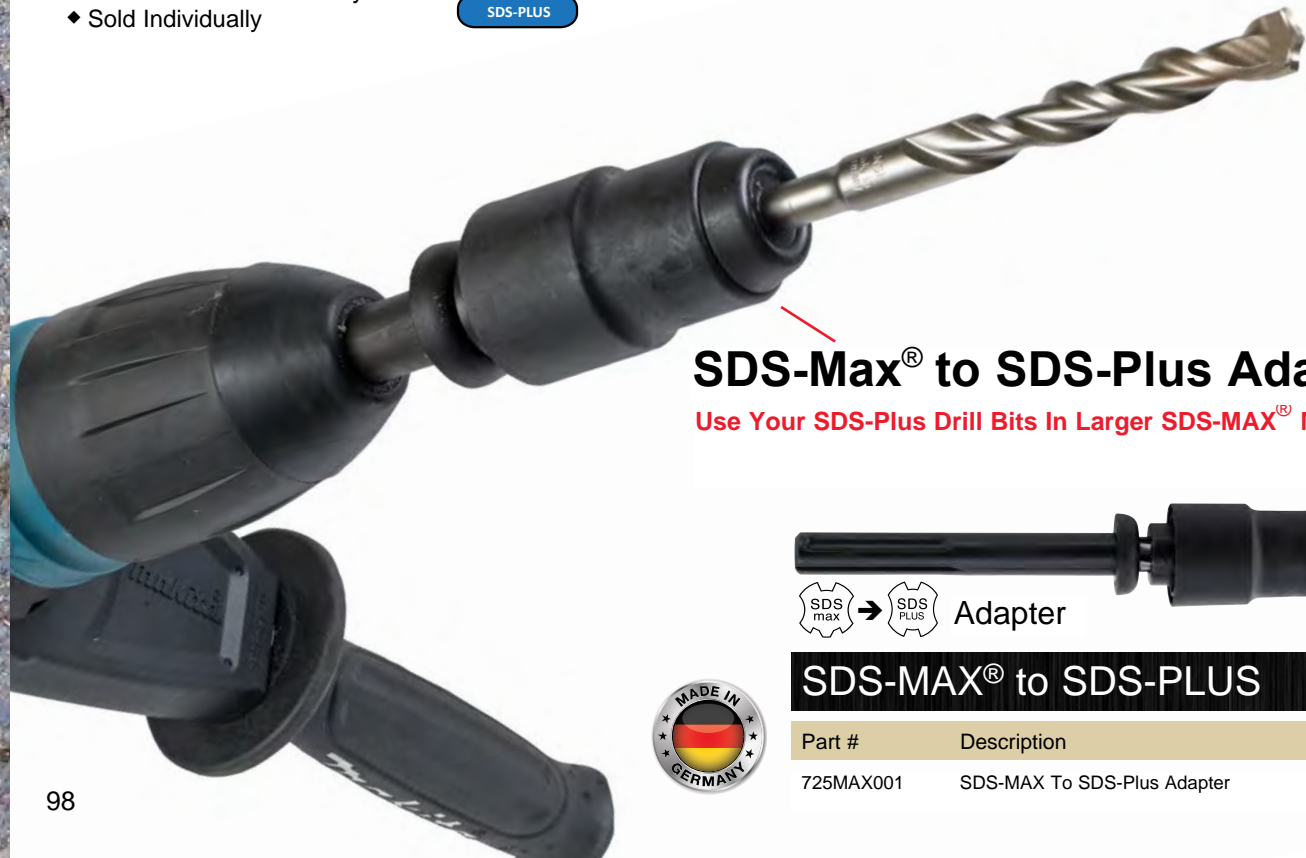

SDS-Max® to SDS-Plus Adapter

Use Your SDS-Plus Drill Bits In Larger SDS-MAX® Machines.



Adapter

SDS-MAX® to SDS-PLUS

Part #	Description
725MAX001	SDS-MAX To SDS-Plus Adapter



Half Flat Shank



Concrete Bits - FOR CONCRETE SCREWS

Part #	Size	x	OAL	Screw	Qty.
602TC0503	5/32"	X	3-1/2"	3/16"	50
602TC0500	5/32"	X	4-1/2"	3/16"	50
602TC0505	5/32"	X	5-1/2"	3/16"	50
602TC0603	3/16"	X	3-1/2"	1/4"	50
602TC0604	3/16"	X	4-1/2"	1/4"	50
602TC0605	3/16"	X	5-1/2"	1/4"	50
602TC0606	3/16"	X	6-3/4"	1/4"	50
602TC0607	3/16"	X	7-5/8"	1/4"	50

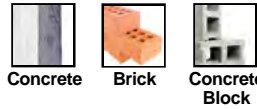

- ◆ Industrial Quality
- ◆ Tungsten Carbide Tip
- ◆ ANSI Specification
- ◆ Sold Individually



Each concrete screw carbide drill bit is precisely ground to match a certain tolerance to assure proper hole diameter and to achieve maximum thread holding power. The flat on the shank fits all drill adapters. The drill bit is specially heat treated to make it very durable.



SDS-HEX Bits - FOR CONCRETE SCREWS

Part #	Size	x	OAL	Drilling	Screw	Qty.
HEX5327	5/32"	X	7"	4-1/2"	3/16"	1
HEX3167	3/16"	X	7"	4-1/2"	1/4"	1
HEX1407	1/4"	X	7"	4-1/2"	5/16"	1

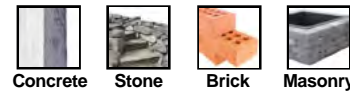

- ◆ Industrial Quality
- ◆ Special Tungsten Carbide Tip
- ◆ ANSI Specification
- ◆ Copper / Silver Brazing
- ◆ Polished Finish
- ◆ Sold Individually



SDS-HEX Rotary Hammer drill bits are specifically designed to be used in concrete screw installation. These SDS bits have a special 5/16" HEX shoulder for use with standard concrete screw installation sleeves, which eliminate the need for drill adapters. The benefits of using an SDS machine rather than a standard rotation drill means a decrease in operation time of nearly 50%. **SEE BELOW FOR INSTALLATION KIT**



Concrete Screw Installation Sleeve

Part #	Description	Qty.
TPCDSL	6-1/2" Concrete Screw Sleeve	1



These Installation Kits are Suitable for both Standard Concrete Bits & SDS-HEX Rotary Hammer Bits.

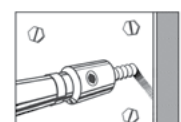
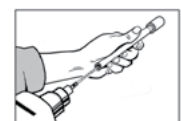
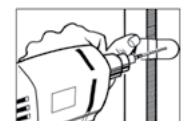

Deluxe Installation Kit

Part #	Description
602TC1000	Installation Kit

INCLUDES:

- 5/32" x 7" SDS-PLUS Hex Bit
- 3/16" x 7" SDS-PLUS Hex Bit
- 1/4" Magnetic Driver
- 5/16" Magnetic Driver
- Phillips Bit Adapter
- Masonry Drill Adapter
- 6-1/2" Sleeve
- 1/8" Hex Key
- Phillips #2 x 1" Insert
- Phillips #3 x 1" Insert

Basic Installation Kit

Part #	Description
602TC2000	Installation Kit

INCLUDES:

- 1/4" Magnetic Driver
- 5/16" Magnetic Driver
- Phillips Bit Adapter
- Masonry Drill Adapter
- 6-1/2" Sleeve
- 1/8" Hex Key
- Phillips #2 x 1" Insert
- Phillips #3 x 1" Insert

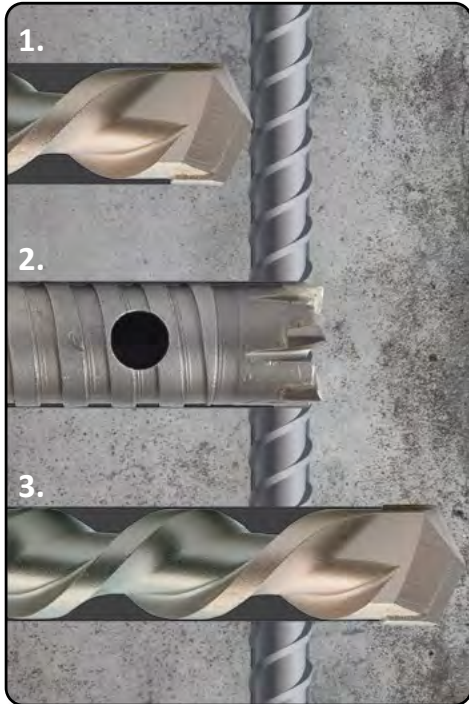

3 SIMPLE STEPS TO DRILLING REBAR

1. When rebar is encountered while drilling, immediately stop the hammer drill and remove the bit from the hole. (failure to do this will severely damage a carbide hammer bit.)
2. With a rotary rebar cutter mounted in a drill motor with the selector in the **rotary only position**, insert the rotary rebar cutter into the hole and drill through the embedded rebar.
3. Remove the rotary rebar cutter after the rebar has been drilled completely through and finish drilling the hole with the hammer bit.

HEAD SIZES

3/8" → 1-1/2"
1-3/4" → 2-1/2"

THREAD

1 pc.
3/4"-10



Rebar Cutter - STRAIGHT SHANK

Part #	Size	OAL	RPM
RBC0838	3/8"	8"	850-1200
RBC1212	1/2"	12"	850-1200
RBC1916	9/16"	12"	850-1200
RBC1258	5/8"	12"	750-1000
RBC1116	11/16"	12"	750-1000
RBC1234	3/4"	12"	600-850
RBC1834	3/4"	18"	600-850
RBC1316	13/16"	12"	600-850
RBC1278	7/8"	12"	600-850
RBC1201	1"	12"	500-750
RBC1218	1-1/8"	12"	500-750
RBC1214	1-1/4"	12"	450-600
RBC1238	1-3/8"	12"	450-600
RBC1112	1-1/2"	12"	350-500
RBC1134	1-3/4"	12"	350-500
RBC1202	2"	12"	350-500
RBC1222	2-1/2"	12"	350-500



SOLD INDIVIDUALLY
1 PER TUBE.

Rotation Only!



Rebar Cutter - SDS-PLUS SHANK

Part #	Size	OAL	RPM
RBS-6	3/8"	8"	850-1200
RBS-8	1/2"	12"	850-1200
RBS-9	9/16"	12"	850-1200
RBS-10	5/8"	12"	750-1000
RBS-11	11/16"	12"	750-1000
RBS-12	3/4"	12"	600-850
RBS-13	13/16"	12"	600-850
RBS-14	7/8"	12"	600-850
RBS-16	1"	12"	500-750
RBS-18	1-1/8"	12"	500-750
RBS-20	1-1/4"	12"	450-600
RBS-22	1-3/8"	12"	450-600
RBS-24	1-1/2"	12"	350-500



SOLD INDIVIDUALLY
1 PER TUBE.

Rotation Only!

Rebar Cutters are problem solvers only. A 1/2" Rebar Cutter drilling through #6 (3/4") rebar dead center may result in 5 to 10 holes being drilled provided correct speed and pressure are utilized. It is not uncommon for only one piece of rebar to be cut per Rebar Cutter. Rebar Cutters *should not* be used for drilling concrete.

Rebar Cutters are not warrantied for replacement or repair.





REBAR PUNCHER

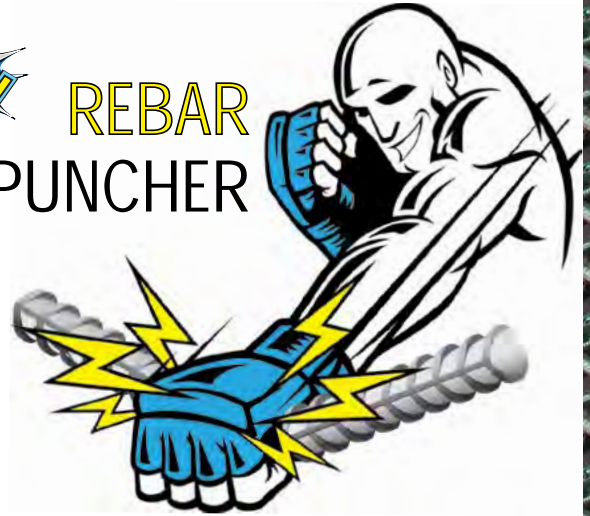

Rebar Puncher - SDS-PLUS SHANK

Part #	Size	OAL	RPM
RT-6	3/8"	12"	HAMMER ACTION
RT-6-18	3/8"	18"	HAMMER ACTION
RT-8	1/2"	12"	HAMMER ACTION
RT-8-18	1/2"	18"	HAMMER ACTION
RT-10	5/8"	12"	HAMMER ACTION
RT-10-18	5/8"	18"	HAMMER ACTION
RT-12	3/4"	12"	HAMMER ACTION
RT-12-18	3/4"	18"	HAMMER ACTION
RT-14	7/8"	12"	HAMMER ACTION
RT-14-18	7/8"	18"	HAMMER ACTION
RT-16	1"	12"	HAMMER ACTION
RT-16-18	1"	18"	HAMMER ACTION
RT-18	1-1/8"	12"	HAMMER ACTION
RT-18-18	1-1/8"	18"	HAMMER ACTION
RT-20	1-1/4"	12"	HAMMER ACTION
RT-20-18	1-1/4"	18"	HAMMER ACTION

BEST ON #5 (5/8") REBAR SIZE AND UNDER.



- ◆ Use in Rotary Hammer Action
- ◆ Industrial Quality
- ◆ Tungsten Carbide Teeth
- ◆ Twice the Speed
- ◆ Sold Individually



Rebar



2X SPEED



USE IN ROTARY HAMMER MODE



Rebar Puncher - SDS-MAX[®] SHANK

Part #	Size	OAL	RPM
RMX-10	5/8"	12"	HAMMER ACTION
RMX-10-21	5/8"	21"	HAMMER ACTION
RMX-12	3/4"	12"	HAMMER ACTION
RMX-12-21	3/4"	21"	HAMMER ACTION
RMX-14	7/8"	12"	HAMMER ACTION
RMX-14-21	7/8"	21"	HAMMER ACTION
RMX-16	1"	12"	HAMMER ACTION
RMX-16-21	1"	21"	HAMMER ACTION
RMX-18	1-1/8"	12"	HAMMER ACTION
RMX-18-21	1-1/8"	21"	HAMMER ACTION
RMX-20	1-1/4"	12"	HAMMER ACTION
RMX-20-21	1-1/4"	21"	HAMMER ACTION
RMX-22	1-3/8"	12"	HAMMER ACTION
RMX-22-21	1-3/8"	21"	HAMMER ACTION
RMX-24	1-1/2"	12"	HAMMER ACTION
RMX-24-21	1-1/2"	21"	HAMMER ACTION
RMX-26	1-3/4"	12"	HAMMER ACTION
RMX-26-21	1-3/4"	21"	HAMMER ACTION

BEST ON #5 (5/8") REBAR SIZE AND UNDER.



- ◆ Use in Rotary Hammer Action
- ◆ Industrial Quality
- ◆ Tungsten Carbide Teeth
- ◆ Twice the Speed
- ◆ Sold Individually



Rebar



SOLD INDIVIDUALLY 1 PER TUBE.





Concrete



Stone



Brick



Masonry



MINI - Bull Point



MINI - Flat Chisel



MINI - Scaling Chisel

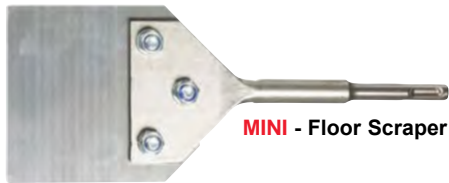

MINI - Floor Scraper

SDS-PLUS Chisels - MINI

Part #	Size	Description
2100BP	5-1/2"	MINI - Bull Point
2110FC	3/4" x 5-1/2"	MINI - Flat Chisel
2115SC	1-1/4" x 5-1/2"	MINI - Scaling Chisel
2244FS	4" x 10"	MINI - Floor Scraper
FS-4B		MINI - Replacement Blade (Floor Scraper)
FS-4NUT		MINI - Replacement Nuts & Bolts (Floor Scraper)



SDS-PLUS Chisels

Part #	Size	Description
3100BP	10"	Bull Point
3110FC	3/4" x 10"	Flat Chisel
3118FC	3/4" x 18"	Flat Chisel
3115SC	1-1/2" x 10"	Scaling Chisel
3122SC	2-1/2" x 10"	Scaling Chisel
3120GC	7/8" x 10"	Gouge Chisel
3150GR	5/8" x 10"	Ground Rod Driver
3175TC	3" x 6-1/2"	Tile Chisel



Bull Point



Flat Chisel



Scaling Chisel



Gouge Chisel



Ground Rod Driver



Tile

SOLD INDIVIDUALLY
1 PER CLIP.

SDS-MAX® Chisels

Part #	Size	Description
7000BP	12"	Bull Point
7005BP	18"	Bull Point
7024BP	24"	Bull Point
7010FC	1" x 12"	Flat Chisel
7015FC	1" x 18"	Flat Chisel
7024FC	1" x 24"	Flat Chisel
7020SC	1-1/2" x 12"	Scaling Chisel
7025SC	2" x 12"	Scaling Chisel
7028SC	2" x 18"	Scaling Chisel
7029SC	2" x 24"	Scaling Chisel
7030SC	3" x 12"	Scaling Chisel
7032SC	3" x 18"	Scaling Chisel
7034SC	3" x 24"	Scaling Chisel
7035AC	2" x 12"	Angled Chisel
7045BT	1-7/8" x 9-7/8"	Bushing Tool
7048CB	1-1/2" x 12"	Carbide Bushing Tool
7050GR	7/8" x 10-1/4"	Ground Rod Driver
7055PH	3-1/2" x 16"	Asphalt Cutter
7060SM	1-1/8" x 12"	Seam Tool
7065CS	5-3/8" x 16"	Clay Spade
7075GC	1" x 12"	Gouge Chisel
7070FS	6" x 25"	Floor Scraper
FS-6B	Replacement Blade (Floor Scraper)	
FS-6NUT	Replacement Nuts & Bolts (Floor Scraper)	



Bull Point



Flat Chisel



Scaling Chisel



Angled Chisel



Bushing Tool



25 CARBIDE TEETH



Carbide Bushing Tool



Ground Rod Driver



Asphalt Cutter



Seam Tool



Clay Spade



Gouge Chisel



Floor Scraper



SOLD INDIVIDUALLY
1 PER CLIP.



Glue



Paint



Epoxy

- ◆ 4 Segment For Mastic Removal
- ◆ Wet Or Dry Cutting
- ◆ For Removal Of Surface Coatings / Porous Ceramic Glue
- ◆ Will Not Smear Like Diamond Cup Wheel
- ◆ Sold Individually



PCD Cup Wheel

Part #	Size	Arbor	Segments	Qty.
PCD-50-4S	5"	7/8" Open	4	1
PCD-50	5"	7/8" Open	6	1
PCD-50T	5"	5/8"-11	6	1
PCD-70	7"	7/8" Open	9	1
PCD-70T	7"	5/8"-11	9	1



OR



SOLD INDIVIDUALLY
1 PER BOX.



Concrete



Brick



Masonry

- ◆ High Diamond Concentration
- ◆ Wet Or Dry Cutting
- ◆ 5/8"-11 Thread or 7/8" Open Hole
- ◆ Sold Individually



Diamond Grinding Cup Wheel

Part #	Size	Arbor	Segments	Qty.
GCW-50	5"	7/8" Open	16	1
GCW-50T	5"	5/8"-11	16	1
GCW-70	7"	7/8" Open	18	1
GCW-70T	7"	5/8"-11	18	1



OR





Sandwich Tuck Pointing Cutting Wheel

Part #	Size	Arbor	Kerf	RPM	Qty.
DD-50	5"	7/8" - 5/8"	0.250	12000	1

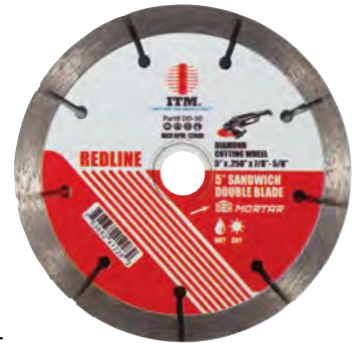

- ◆ Wet Or Dry Cutting
- ◆ Fast & Aggressive
- ◆ 10 mm Segments
- ◆ 7/8"-5/8" Brass Arbor
- ◆ Sold Individually



Segmented Tuck Pointing Cutting Wheel

Part #	Size	Arbor	Kerf	RPM	Qty.
UT-40	4"	7/8" - 5/8"	0.250	15000	1



- ◆ Wet Or Dry Cutting
- ◆ Fast & Aggressive
- ◆ 10 mm Segments
- ◆ 7/8"-5/8" Brass Arbor
- ◆ Sold Individually

Bushings

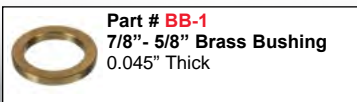

Part # BB-1
7/8" - 5/8" Brass Bushing
0.045" Thick



Part # BB-TP
7/8" - 5/8" Brass Bushing
0.125" Thick For Tuck Point



Part # BB-14
1" - 20MM Brass Bushing
0.085" Thick for 14" Blades

Packaging Options



BLISTER PACK
(1 BLADE)



BULK BOX
(10 BLADES)

REDLINE

DIAMOND CUTTING WHEELS



INTERNATIONAL TOOL MANUFACTURING

150 Express St. Plainview, NY 11803

(516) 738-0388 • (800) 247-5696

ITM Fax (516) 279-1106

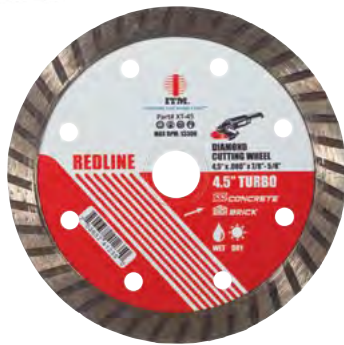

- ◆ Wet Or Dry Cutting
- ◆ Fast & Aggressive
- ◆ 10 mm Segments
- ◆ 7/8"-5/8" Brass Arbor
- ◆ Sold Individually & packs of 10.

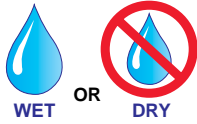

Turbo Diamond Cutting Wheel

Part #	Size	Arbor	Kerf	RPM	Qty.
XT-40	4"	7/8"- 5/8"	0.080	15000	1
XT-40-A	4"	7/8"- 5/8"	0.080	15000	10
XT-45	4-1/2"	7/8"- 5/8"	0.080	13300	1
XT-45-A	4-1/2"	7/8"- 5/8"	0.080	13300	10
XT-70	7"	UA - 7/8"- 5/8"	0.090	8730	1

7/8" Diamond Knock Out For Worm Drive



- ◆ Wet Or Dry Cutting
- ◆ Fast & Aggressive
- ◆ 10 mm Segments
- ◆ 7/8"-5/8" Brass Arbor
- ◆ Sold Individually & packs of 10.



Segmented Diamond Cutting Wheel

Part #	Size	Arbor	Kerf	RPM	Qty.
SG-40	4"	7/8"- 5/8"	0.080	15000	1
SG-40-A	4"	7/8"- 5/8"	0.080	15000	10
SG-45	4-1/2"	7/8"- 5/8"	0.080	13300	1
SG-45-A	4-1/2"	7/8"- 5/8"	0.080	13300	10
SG-70	7"	UA - 7/8"- 5/8"	0.090	8730	1

7/8" Diamond Knock Out For Worm Drive



14" Segmented Diamond Cutting Wheel - General Use

Part #	Size	Arbor	Kerf	RPM	Qty.
SG-14	14"	1"- 20mm	0.125	5460	1

- ◆ Wet Or Dry Cutting
- ◆ Fast & Aggressive
- ◆ 10 mm Segments
- ◆ Brass Arbor
- ◆ Sold Individually.





14" Segmented Diamond Cutting Wheel - Multi-Material

Part #	Size	Arbor	Kerf	RPM	Qty.
MA-14	14"	1"- 20mm	0.125	5460	1



- ◆ Made In USA
- ◆ Multi-Materials
- ◆ Laser Welded Turbo Segments
- ◆ 12 mm Segments
- ◆ Brass Arbor
- ◆ Sold Individually



14" Segmented Diamond Cutting Wheel - Heavy Duty

Part #	Size	Arbor	Kerf	RPM	Qty.
KS-14	14"	1"- 20mm	0.125	5460	1



- ◆ Heavy Duty
- ◆ Laser Welded Turbo Segments
- ◆ 12 mm Segments
- ◆ Brass Arbor
- ◆ Sold Individually



14" Segmented Diamond Cutting Wheel - Demo Rescue

Part #	Size	Arbor	Kerf	RPM	Qty.
CC-14	14"	1"- 20mm	0.142	5460	1

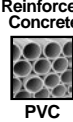

- ◆ Metal Cutting
- ◆ Laser Welded Segments
- ◆ Brazed Diamond
- ◆ Brass Arbor
- ◆ Sold Individually



⊕ Phillips

PHILLIPS POINT #	SHEET METAL SCREWS	WOOD SCREWS		MACHINE SCREWS		
	FLAT, ROUND, OVAL STOVE BINDING	FLAT, OVAL	ROUND	FLAT, OVAL BINDING	ROUND, FILLISTER	TRUSS, BRAZIER BUTTON
0	0, 1	0, 1	0, 1	0, 1	0, 1	0, 1
1	2, 3, 4	2, 3, 4	2, 3, 4	2, 3, 4	2, 3, 4	2, 3, 4, 5
2	5, 6, 7, 8, 10	5, 6, 7, 8, 9	5, 6, 7, 8, 9, 10	5, 6, 8, 10	5, 6, 8, 10	6, 8, 10
3	12, 14	10, 12, 14, 16	12, 14, 16	12, 1/4"	12, 1/4", 5/16"	12, 1/4"

◐ Slotted

SLOTTED POINT #	SCREW SIZE	SLOT SCREW WIDTH		THREAD DIA.	MAXIMUM HEAD DIAMETER					
		MIN.	MAX.		FLAT or OVAL HEAD	ROUND HEAD	FILLISTER HEAD	BINDING HEAD	PAN HEAD	TRUSS HEAD
4-5	3	.027	.035	.099	.199	.187	.161	.208	.193	.226
4-5	4	.031	.039	.112	.225	.211	.183	.235	.219	.257
6-8	5	.035	.043	.125	.252	.236	.205	.263	.245	.289
8-10	6	.039	.048	.138	.279	.260	.226	.290	.270	.321
10-12	8	.045	.054	.164	.332	.309	.270	.344	.322	.384

◑ Square

SQUARE POINT #	TAPPING SCREWS	WOOD SCREWS	MACHINE SCREWS
0	3, 4	3, 4	3, 4
1	5, 6, 7	5, 6, 7	5, 6
2	8, 10	8, 9, 10	8, 10
3	12, 14	12, 14	12, 14

⬠ Star FOR TORX® SCREWS.

SCREW SIZE	THREAD DIA.	INTERNAL TORX WASHER HEAD	PAN HEAD	FLAT HEAD	HEX HEAD	TRUSS HEAD	FILLISTER HEAD	OVAL HEAD	SOCKET HEAD CAP	SOCKET SET SCREW
2	.086	T7	T7	T6						
3	.099	T8	T8	T7						
4	.112	T9	T9	T8	T9		T9		T10	T6
5	.125	T10	T10	T9	T10		T10	T10	T10	T7
6	.138	T15	T15	T10	T15	T10	T15	T15	T15	T7
8	.164	T20	T20	T15	T20	T15	T20	T20	T25	T8
10	.190	T25	T25	T20	T25	T20	T25	T25	T27	T10
12	.216	T27	T27	T25	T27	T25	T27	T27	T27	T10
1/4"	.250	T30	T30	T27	T30	T27	T30	T30	T30	T20
5/16"	.312			T40	T40	T40	T340	T40	T45	T27
3/8"	.375		T45	T40	T45	T45	T45	T45	T50	T30
7/16"	.437		T50	T50		T45	T50	T50	T55	T40
1/2"	.500		T55	T50		T50	T55	T50	T55	T45



1/4" Drive Magnetic Screwdriver
With Insert Bit Storage Handle. *BITS NOT INCLUDED.*

Part #	Drive	Description
HH-08-001	1/4"	8" MAGNETIC STORAGE HANDLE



STAINLESS STEEL SHAFT



1/4" Drive Magnetic Flexible Screwdriver

Part #	Drive	Description
HAN-1	1/4"	10" Magnetic Flexible Screwdriver (1/4" Bits)

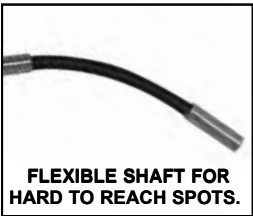

1/4" Drive Quick Change Screwdriver

Part #	Drive	Description
HAN-2	1/4"	1/4" Quick Change Screwdriver (1/4" Bits)



Insert Bit Countertop Dispenser

Part #	Type	Qty.
BITDIS	EMPTY DISPLAY	1

KEEP YOUR INSERT BITS AND NUT SETTERS SAFE AND ORGANIZED.



- ◆ Sold Empty
- ◆ Make Your Own Assortment
- ◆ Display Made In Canada





Phillips® Insert Bits - 1/4" Hex

Part #	Size	OAL	Type	Qty.
T3-025-00	#0 X 1"		PHILLIPS INSERT	25
T3-025-01	#1 X 1"		PHILLIPS INSERT	25
T3-025-02	#2 X 1"		PHILLIPS INSERT	25
T3-025-03	#3 X 1"		PHILLIPS INSERT	25
T3-025-04	#4 X 1"		PHILLIPS INSERT	25



Reduced Body

Phillips® Drywall Bits - 1/4" Hex

Part #	Size	OAL	Type	Qty.
T3-025-1W	#1 X 1"		PHILLIPS DRYWALL	25
T3-025-2W	#2 X 1"		PHILLIPS DRYWALL	25



Phillips® Insert Bits - 5/16" Hex

Part #	Size	OAL	Type	Qty.
T3-032-01	#1 X 1-1/4"		PHILLIPS INSERT	25
T3-032-02	#2 X 1-1/4"		PHILLIPS INSERT	25
T3-032-03	#3 X 1-1/4"		PHILLIPS INSERT	25



Phillips® Stopper - 1/4" Hex

Part #	Size	OAL	Type	Qty.
SP-025-2P	#2 X 1"		PHILLIPS STOPPER	25



Phillips® ACR® Insert Bits - 1/4" Hex

Part #	Size	OAL	Type	Qty.
ACR-025-01	#1 X 1"		PHILLIPS ACR INSERT	25
ACR-025-02	#2 X 1"		PHILLIPS ACR INSERT	25
ACR-025-03	#3 X 1"		PHILLIPS ACR INSERT	25



Phillips® Power Bits - 1/4" Hex

Part #	Size	OAL	Type	Qty.
T3-050-01	#1 X 2"		PHILLIPS POWER	25
T3-070-01	#1 X 2-3/4"		PHILLIPS POWER	25
T3-075-01	#1 X 3"		PHILLIPS POWER	25
T3-090-01	#1 X 3-1/2"		PHILLIPS POWER	25
T3-100-01	#1 X 4"		PHILLIPS POWER	25
T3-125-01	#1 X 5"		PHILLIPS POWER	25
T3-150-01	#1 X 6"		PHILLIPS POWER	25
T3-050-02	#2 X 2"		PHILLIPS POWER	25
T3-070-02	#2 X 2-3/4"		PHILLIPS POWER	25
T3-075-02	#2 X 3"		PHILLIPS POWER	25
T3-090-02	#2 X 3-1/2"		PHILLIPS POWER	25
T3-100-02	#2 X 4"		PHILLIPS POWER	25
T3-125-02	#2 X 5"		PHILLIPS POWER	25
T3-150-02	#2 X 6"		PHILLIPS POWER	25
T3-050-03	#3 X 2"		PHILLIPS POWER	25
T3-070-03	#3 X 2-3/4"		PHILLIPS POWER	25
T3-075-03	#3 X 3"		PHILLIPS POWER	25
T3-090-03	#3 X 3-1/2"		PHILLIPS POWER	25
T3-100-03	#3 X 4"		PHILLIPS POWER	25
T3-125-03	#3 X 5"		PHILLIPS POWER	25
T3-150-03	#3 X 6"		PHILLIPS POWER	25



Reduced Body

Phillips® Drywall Power Bits - 1/4" Hex

Part #	Size	OAL	Type	Qty.
T3-050-2W	#2 X 2"		PHILLIPS POWER	25
T3-070-2W	#2 X 2-3/4"		PHILLIPS POWER	25
T3-090-2W	#2 X 3-1/2"		PHILLIPS POWER	25



Phillips® ACR® Power Bits - 1/4" Hex

Part #	Size	OAL	Type	Qty.
ACR-050-01	#1 X 2"		PHILLIPS ACR POWER	25
ACR-050-02	#2 X 2"		PHILLIPS ACR POWER	25
ACR-050-03	#3 X 2"		PHILLIPS ACR POWER	25



For Torx® Screws

Star Insert Bits - 1/4" Hex

Part #	Size	OAL	Type	Qty.
TX-025-04	T4	X 1"	STAR INSERT	25
TX-025-06	T6	X 1"	STAR INSERT	25
TX-025-07	T7	X 1"	STAR INSERT	25
TX-025-08	T8	X 1"	STAR INSERT	25
TX-025-09	T9	X 1"	STAR INSERT	25
TX-025-10	T10	X 1"	STAR INSERT	25
TX-025-15	T15	X 1"	STAR INSERT	25
TX-025-20	T20	X 1"	STAR INSERT	25
TX-025-25	T25	X 1"	STAR INSERT	25
TX-025-27	T27	X 1"	STAR INSERT	25
TX-025-30	T30	X 1"	STAR INSERT	25
TX-025-40	T40	X 1"	STAR INSERT	25



For Torx® Screws

Star Insert Bits - 5/16" Hex

Part #	Size	OAL	Type	Qty.
TX-032-30	T30	X 1-1/4"	STAR INSERT	25
TX-032-40	T40	X 1-1/4"	STAR INSERT	25
TX-032-45	T45	X 1-1/4"	STAR INSERT	25
TX-032-50	T50	X 1-1/4"	STAR INSERT	25
TX-032-55	T55	X 1-1/4"	STAR INSERT	25



For Torx® Screws

Star Power Bits - 1/4" Hex

Part #	Size	OAL	Type	Qty.
TX-050-10	T10	X 2"	STAR POWER	25
TX-150-10	T10	X 6"	STAR POWER	25
TX-050-15	T15	X 2"	STAR POWER	25
TX-150-15	T15	X 6"	STAR POWER	25
TX-050-20	T20	X 2"	STAR POWER	25
TX-150-20	T20	X 6"	STAR POWER	25
TX-050-25	T25	X 2"	STAR POWER	25
TX-150-25	T25	X 6"	STAR POWER	25
TX-050-27	T27	X 2"	STAR POWER	25
TX-150-27	T27	X 6"	STAR POWER	25
TX-050-30	T30	X 2"	STAR POWER	25
TX-150-30	T30	X 6"	STAR POWER	25
TX-050-40	T40	X 2"	STAR POWER	25
TX-150-40	T40	X 6"	STAR POWER	25



Square Insert Bits - 1/4" Hex

Part #	Size	OAL	Type	Qty.
T3-R25-00	#0	X 1"	SQUARE INSERT	25
T3-R25-01	#1	X 1"	SQUARE INSERT	25
T3-R25-02	#2	X 1"	SQUARE INSERT	25
T3-R25-03	#3	X 1"	SQUARE INSERT	25



Square Power Bits - 1/4" Hex

Part #	Size	OAL	Type	Qty.
T3-R50-01	#1	X 2"	SQUARE POWER	25
T3-R70-01	#1	X 2-3/4"	SQUARE POWER	25
T3-R75-01	#1	X 3"	SQUARE POWER	25
T3-R90-01	#1	X 3-1/2"	SQUARE POWER	25
T3-R10-01	#1	X 4"	SQUARE POWER	25
T3-R12-01	#1	X 5"	SQUARE POWER	25
T3-R15-01	#1	X 6"	SQUARE POWER	25
T3-R50-02	#2	X 2"	SQUARE POWER	25
T3-R70-02	#2	X 2-3/4"	SQUARE POWER	25
T3-R75-02	#2	X 3"	SQUARE POWER	25
T3-R90-02	#2	X 3-1/2"	SQUARE POWER	25
T3-R10-02	#2	X 4"	SQUARE POWER	25
T3-R12-02	#2	X 5"	SQUARE POWER	25
T3-R15-02	#2	X 6"	SQUARE POWER	25
T3-R50-03	#3	X 2"	SQUARE POWER	25
T3-R70-03	#3	X 2-3/4"	SQUARE POWER	25
T3-R75-03	#3	X 3"	SQUARE POWER	25
T3-R90-03	#3	X 3-1/2"	SQUARE POWER	25
T3-R10-03	#3	X 4"	SQUARE POWER	25
T3-R12-03	#3	X 5"	SQUARE POWER	25
T3-R15-03	#3	X 6"	SQUARE POWER	25



Quick Change Extensions
P. 116

- ◆ All LIST Per Piece
- ◆ Sold in QTY 25
- ◆ S2 Modified Steel
- ◆ Rc. 58-62 Heat Treated
- ◆ German Grade Steel





Poizdriv® Insert Bits - 1/4" Hex

Part #	Size	OAL	Type	Qty.
PZ-025-01	#1 X 1"		POZIDRIV INSERT	25
PZ-025-02	#2 X 1"		POZIDRIV INSERT	25
PZ-025-03	#3 X 1"		POZIDRIV INSERT	25



Poizdriv® Power Bits - 1/4" Hex

Part #	Size	OAL	Type	Qty.
PZ-050-01	#1 X 2"		POZIDRIV POWER	25
PZ-050-02	#2 X 2"		POZIDRIV POWER	25
PZ-075-02	#2 X 3"		POZIDRIV POWER	25
PZ-050-03	#3 X 2"		POZIDRIV POWER	25



Double End Bits - 1/4" Hex

Part #	Size	Qty.
DW-050-22	#2 PHILLIPS / #2 PHILLIPS	25
DW-050-26	#2 PHILLIPS / #6-8 SLOTTED	25
DW-050-28	#2 PHILLIPS / #8-10 SLOTTED	25



Phillips® Power Bits - 1/4" Hex

Part #	Size	OAL	Type	Qty.
BLU-025-02	#2 X 1-3/16"		PHILLIPS POWER	25
BLU-050-02	#2 X 2"		PHILLIPS POWER	25
BLU-025-03	#3 X 1-3/16"		PHILLIPS POWER	25
BLU-050-03	#3 X 2"		PHILLIPS POWER	25



Bit Holder - Magnetic - 1/4" Hex

Part #	Size	OAL	Type	Qty.
BH-060-BLU	1/4"	1-3/16"	Retaining Ring	1



Hex Insert Bits - 1/4" Hex

Part #	Size	OAL	Type	Qty.
HE-25-564	5/64" X 1"		HEX INSERT	25
HE-25-332	3/32" X 1"		HEX INSERT	25
HE-25-764	7/64" X 1"		HEX INSERT	25
HE-25-864	1/8" X 1"		HEX INSERT	25
HE-25-532	5/32" X 1"		HEX INSERT	25
HE-25-316	3/16" X 1"		HEX INSERT	25



Hex Insert Bits - 5/16" Hex

Part #	Size	OAL	Type	Qty.
HE-32-316	3/16" X 1-1/4"		HEX INSERT	25
HE-32-732	7/32" X 1-1/4"		HEX INSERT	25
HE-32-014	1/4" X 1-1/4"		HEX INSERT	25



Slotted Insert Bits - 1/4" Hex

Part #	Size	OAL	Type	Qty.
ST-025-04	#4-5 X 1"		SLOTTED INSERT	25
ST-025-08	#6-8 X 1"		SLOTTED INSERT	25
ST-025-10	#8-10 X 1"		SLOTTED INSERT	25
ST-025-12	#10-12 X 1"		SLOTTED INSERT	25



Slotted Power Bits - 1/4" Hex

Part #	Size	OAL	Type	Qty.
ST-050-04	#4-5 X 2"		SLOTTED POWER	25
ST-050-08	#6-8 X 2"		SLOTTED POWER	25
ST-050-10	#8-10 X 2"		SLOTTED POWER	25
ST-070-10	#8-10 X 3"		SLOTTED POWER	25
ST-090-10	#8-10 X 3-1/2"		SLOTTED POWER	25
ST-050-12	#10-12 X 2"		SLOTTED POWER	25



Spanner Insert Bits - 1/4" Hex

Part #	Size	OAL	Type	Qty.
SP-025-04	#4 X 1"		SPANNER	25
SP-025-06	#6 X 1"		SPANNER	25
SP-025-08	#8 X 1"		SPANNER	25
SP-025-10	#10 X 1"		SPANNER	25
SP-025-12	#12 X 1"		SPANNER	25
SP-025-14	#14 X 1"		SPANNER	25



Hex Tamper Insert Bits - 1/4" Hex

Part #	Size	OAL	Type	Qty.
TH-25-332	3/32" X 1"		HEX TAMPER	25
TH-25-018	1/8" X 1"		HEX TAMPER	25
TH-25-964	9/64" X 1"		HEX TAMPER	25
TH-25-532	5/32" X 1"		HEX TAMPER	25
TH-25-316	3/16" X 1"		HEX TAMPER	25
TH-25-732	7/32" X 1"		HEX TAMPER	25
TH-25-014	1/4" X 1"		HEX TAMPER	25
TH-25-516	5/16" X 1"		HEX TAMPER	25



Phillips® Tamper Insert Bits - 1/4" Hex

Part #	Size	OAL	Type	Qty.
TP-025-02	#2 X 1"		PHILLIPS TAMPER	25
TP-025-03	#3 X 1"		PHILLIPS TAMPER	25



Tri-Wing® Tamper Insert Bits - 1/4" Hex

Part #	Size	OAL	Type	Qty.
TRI-25-01	#1 X 1"		TRI-WING	25
TRI-25-02	#2 X 1"		TRI-WING	25
TRI-25-03	#3 X 1"		TRI-WING	25

TAMPER PROOF SECURITY BITS

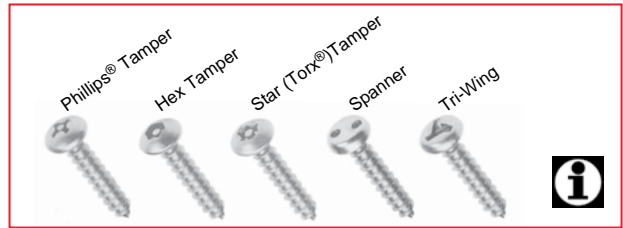

For TAMPER RESISTANT Torx® Screws

Star Tamper Insert Bits - 1/4" Hex

Part #	Size	OAL	Type	Qty.
TT-025-08	T8 X 1"		STAR TAMPER	25
TT-025-09	T9 X 1"		STAR TAMPER	25
TT-025-10	T10 X 1"		STAR TAMPER	25
TT-025-15	T15 X 1"		STAR TAMPER	25
TT-025-20	T20 X 1"		STAR TAMPER	25
TT-025-25	T25 X 1"		STAR TAMPER	25
TT-025-27	T27 X 1"		STAR TAMPER	25
TT-025-30	T30 X 1"		STAR TAMPER	25
TT-025-40	T40 X 1"		STAR TAMPER	25



For TAMPER RESISTANT Torx® Screws

Star Tamper Insert Bits - 5/16" Hex

Part #	Size	OAL	Type	Qty.
TT-032-45	T45 X 1-1/4"		STAR TAMPER	25
TT-032-50	T50 X 1-1/4"		STAR TAMPER	25
TT-032-55	T55 X 1-1/4"		STAR TAMPER	25

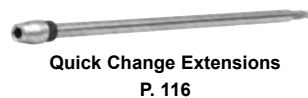

- ◆ All LIST Per Piece
- ◆ Sold in QTY 25
- ◆ S2 Modified Steel
- ◆ Rc. 58-62 Heat Treated
- ◆ German Grade Steel





Phillips® Insert Bits - 1/4" Hex

Part #	Size	OAL	Type	Bits
PH1-1	#1 X 1"		PHILLIPS INSERT	25
PH2-1	#2 X 1"		PHILLIPS INSERT	25
PH3-1	#3 X 1"		PHILLIPS INSERT	25
PH1-2	#1 X 2"		PHILLIPS POWER	10
PH2-2	#2 X 2"		PHILLIPS POWER	10
PH3-2	#3 X 2"		PHILLIPS POWER	10
PH2-D	#2 X 1"		Ph. Drywall Reduced Head	25



For Torx® Screws

Star Insert Bits - 1/4" Hex

Part #	Size	OAL	Type	Bits
TX-10	T10 X 1"		STAR INSERT	25
TX-15	T15 X 1"		STAR INSERT	25
TX-20	T20 X 1"		STAR INSERT	25
TX-25	T25 X 1"		STAR INSERT	25
TX-27	T27 X 1"		STAR INSERT	25
TX-30	T30 X 1"		STAR INSERT	25
TX-40	T40 X 1"		STAR INSERT	25
TX2-10	T10 X 2"		STAR POWER	10
TX2-15	T15 X 2"		STAR POWER	10
TX2-20	T20 X 2"		STAR POWER	10
TX2-25	T25 X 2"		STAR POWER	10
TX2-27	T27 X 2"		STAR POWER	10
TX2-30	T30 X 2"		STAR POWER	10
TX2-40	T40 X 2"		STAR POWER	10



- ◆ S2 Modified Steel
- ◆ Rc. 58-62 Heat Treated
- ◆ German Grade Steel
- ◆ Made In Taiwan
- ◆ 1" Length (25 Per Pack)
- ◆ 2" Length (10 Per Pack)

Part# DIS-12
6.5" x 6.5" (Display Only)

List Price is Per Pack.



Square Insert Bits - 1/4" Hex

Part #	Size	OAL	Type	Bits
SQ1-1	#1 X 1"		SQUARE INSERT	25
SQ2-1	#2 X 1"		SQUARE INSERT	25
SQ3-1	#3 X 1"		SQUARE INSERT	25
SQ2-2	#2 X 2"		SQUARE POWER	10
SQ3-2	#3 X 2"		SQUARE POWER	10



Slotted Insert Bits - 1/4" Hex

Part #	Size	OAL	Type	Bits
SL4-1	#4-5 X 1"		SLOTTED INSERT	25
SL6-1	#6-8 X 1"		SLOTTED INSERT	25
SL8-1	#8-10 X 1"		SLOTTED INSERT	25
SL10-1	#10-12 X 1"		SLOTTED INSERT	25



Hex Insert Bits - 1/4" Hex

Part #	Size	OAL	Type	Bits
HE-564	5/64" X 1"		HEX INSERT	25
HE-332	3/32" X 1"		HEX INSERT	25
HE-764	7/64" X 1"		HEX INSERT	25
HE-180	1/8" X 1"		HEX INSERT	25
HE-532	5/32" X 1"		HEX INSERT	25
HE-316	3/16" X 1"		HEX INSERT	25

TIC TAC SINGLES



Phillips® Insert Bits - 1 INCH

Part #	Size	OAL	Type	Packs
PH2-1B	#2 X 1"		PHILLIPS INSERT	12
PH3-1B	#3 X 1"		PHILLIPS INSERT	12

EACH 1" TIC TAC PACK CONTAINS 25 BITS.



BULK TIC TAC COUNTER DISPLAY



Phillips® Power Bits - 2 INCH

Part #	Size	OAL	Type	Packs
PH2-2B	#2 X 2"		PHILLIPS POWER	12
PH3-2B	#3 X 2"		PHILLIPS POWER	12

EACH 2" TIC TAC PACK CONTAINS 10 BITS.



3" Bit Holder - SS - Magnetic

Part #	Size	Type	Ea.
BH-075-CLIP	1/4"	1/4" - Retaining Ring	1



1" Insert Bit Keychain

Part #	OAL	Type	Qty.
T3-KEY-B	1"	10 Pc. GENERAL	10



2" Insert Bit Phillips®

Part #	OAL	Type	Qty.
T3-KEY2-B	2"	PHILLIPS #2	10

2" Insert Bit Square

Part #	OAL	Type	Qty.
T3-KEY3-B	2"	SQUARE #2	10

2" Insert Bit SQ / PH

Part #	OAL	Type	Qty.
T3-KEY4-B	2"	SQ #2 / PH #2	10



2" Insert Bit Square

Part #	OAL	Type	Qty.
T3-KEY5-B	2"	SQUARE #1,2,3	10

2" Insert Bit Phillips®

Part #	OAL	Type	Qty.
T3-KEY6-B	2"	PHILLIPS #1,2,3	10

2-9/16" Nut Setter - 5 Pc.

Part #	OAL	Type	Qty.	List/Box
T3-NUT1-B	2-9/16"	1/4"-1/2"	10	



INTERNATIONAL TOOL MANUFACTURING

150 Express St. Plainview, NY 11803

(516) 738-0388 • (800) 247-5696

ITM® Fax (516) 279-1106



TECH 3
SCREWDRIVER BITS
S2 MODIFIED STEEL



SOLD INDIVIDUALLY.



1/4" Bit Holders - Stainless + Carbon - Magnetic

Part #	OAL	Body Dia.	Retaining Ring	Description
BH-020-RC	1-3/4"	7/16"	NO	2PC. CONSTRUCTION
BH-060-40	2-5/8"	3/8"	NO	2PC. CONSTRUCTION
BH-075-14	3"	7/16"	NO	2PC. CONSTRUCTION
BH-075-14R	3"	7/16"	YES	2PC. CONSTRUCTION



1/4" Bit Holders - Stainless Steel - Magnetic

Part #	OAL	Body Dia.	Retaining Ring	Description
BH-040-RC	1-13/16"	7/16"	YES	1PC. CONSTRUCTION
BH-060-RC	2-5/8"	7/16"	YES	1PC. CONSTRUCTION
BH-075-RC	3"	7/16"	YES	1PC. CONSTRUCTION
BH-100-TR	3"	7/16"	THREADED	1PC. CONSTRUCTION
BH-100-RC	4"	7/16"	YES	1PC. CONSTRUCTION
BH-150-RC	6"	7/16"	YES	1PC. CONSTRUCTION



5/16" Bit Holders - Stainless Steel - Magnetic

Part #	OAL	Body Dia.	Retaining Ring	Description
LBH-1	3-1/2"	1/2"	YES	2PC. CONSTRUCTION
LBH-2	3"	1/2"	YES	1PC. CONSTRUCTION

1/4" IMPACT SHANK ↑

5/16" IMPACT SHANK ↑

1/4" Hex Quick Change Extensions

Part #	OAL	Body Dia.	Retaining Ring	Description
EXT-300	12"	5/8"	LOCK	12" EXTENSION
EXT-500	18"	5/8"	LOCK	18" EXTENSION





SOLD INDIVIDUALLY.

Lag Driver / Ceiling Tile Hanger Driver

Part #	OAL	Body Dia.	Driver Size	Description
CE-075-14SL	2-1/2"	5/8"	7/16"	LAG DRIVER WITH SLEEVE



For Eye Lag Screws to install suspended drop down ceilings.

1/4" Quick Lock Bit Holders

Part #	OAL	Body Dia.	Retaining Ring	Description
QRS-2	2"	9/16"	YES / LOCK	QUICK LOCK HOLDER
QRS-3	3"	9/16"	YES / LOCK	QUICK LOCK HOLDER
QRS-4	4"	9/16"	YES / LOCK	QUICK LOCK HOLDER
QRS-6	6"	9/16"	YES / LOCK	QUICK LOCK HOLDER



Pull back system locks in 1" bits.



SOLD 8 PCS. IN A PLASTIC TUBE.

1/4" Sleeve Guide Bit Holders

Part #	OAL	Body Dia.	Retaining Ring	Description
BH-075-SL	3"	7/16"	NO	SLEEVE GUIDE HOLDER
BH-125-SL	5"	7/16"	NO	SLEEVE GUIDE HOLDER



Sleeve extends up to 8" (on 5" length sleeve guide) to hold screw while fastening.



7-1/2" Flexible Bit Holder

Part #	OAL	Body Dia.	Retaining Ring	Description
FX-075-01	7-1/2"	1/2"	YES / BALL	FLEXIBLE BIT HOLDER

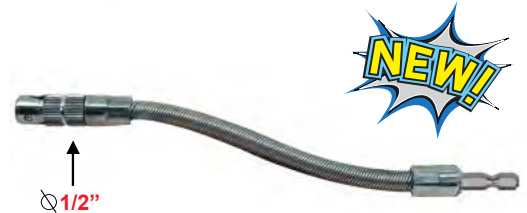

Flexible shaft can bend up to 45° for hard to reach areas.
SOLD INDIVIDUALLY ON HANGING CLIP.



For 1" Insert Bits.

- ◆ 1/4" Hex Impact Shank
- ◆ 45° Bendable Shaft
- ◆ Made In Taiwan



12" Flexible Bit Holder - Quick Change

Part #	OAL	Body Dia.	Retaining Ring	Description
FX-120-01	12"	3/4"	YES / LOCK	FLEXIBLE BIT HOLDER



Quick Insert / Quick Spring Out Chuck.
SOLD INDIVIDUALLY ON HANGING CLIP.



For Power Bits Only.

- ◆ 1/4" Hex Impact Shank
- ◆ Quick-Change
- ◆ Heavy Duty
- ◆ Made In Taiwan





1/2" DRILL



IMPACT DRIVER

SOLD INDIVIDUALLY.



IMPACT
1/4" HEX IMPACT SHANK



MAGNETIC



1/4" DRIVE

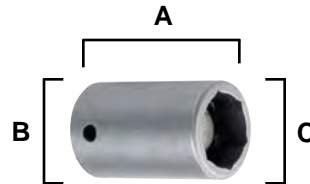

1/4" Square Drive Extension

Part #	OAL
AD-025-14	1"
AD-032-14	1-1/4"
AD-050-14	2"
AD-075-14	3"
AD-100-14	4"
AD-150-14	5"
AD-200-14	6"

1/4" Square Drive Impact Sockets

Part #	Hex Size	Length (A)	Body (B)	Nose (C)
250ST1264	3/16"	15/16"	1/2"	3/8"
250ST1664	1/4"	15/16"	1/2"	7/16"
250ST2064	5/16"	15/16"	1/2"	1/2"
250ST2464	3/8"	1"	5/8"	9/16"
250ST3264	1/2"	1"	3/4"	3/4"



3/8" DRIVE

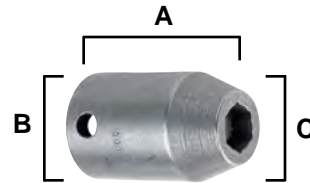

3/8" Square Drive Extension

Part #	OAL
AD-050-38	2"
AD-075-38	3"
AD-100-38	4"
AD-150-38	6"
AD-200-38	8"

3/8" Square Drive Impact Sockets

Part #	Hex Size	Length (A)	Body (B)	Nose (C)
375ST1664	1/4"	1-1/4"	3/4"	7/16"
375ST2064	5/16"	1-1/4"	3/4"	1/2"
375ST2464	3/8"	1-1/4"	3/4"	9/16"
375ST3264	1/2"	1-1/2"	15/16"	3/4"



1/2" DRIVE

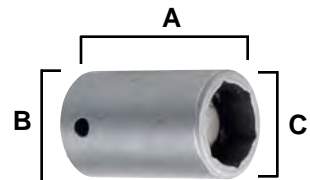

1/2" Square Drive Extension

Part #	OAL
AD-055-12	2-1/8"
AD-075-12	3"
AD-150-12	6"
AD-200-12	8"

1/2" Square Drive Impact Sockets

Part #	Hex Size	Length (A)	Body (B)	Nose (C)
500ST1664	1/4"	1-1/2"	15/16"	7/16"
500ST2064	5/16"	1-1/2"	15/16"	1/2"
500ST2464	3/8"	1-1/2"	15/16"	9/16"
500ST3264	1/2"	1-1/2"	15/16"	3/4"

Nut Setters - Magnetic *IMPACT*

Part #	Hex Head Size	X	OAL	Type	Qty.
IMP-042-16	1/4"	X	1-3/4"	MAG. POWER	10
IMP-065-16	1/4"	X	2-9/16"	MAG. POWER	10
IMP-075-16	1/4"	X	4"	MAG. POWER	5
IMP-085-16	1/4"	X	6"	MAG. POWER	5
IMP-042-20	5/16"	X	1-3/4"	MAG. POWER	10
IMP-065-20	5/16"	X	2-9/16"	MAG. POWER	10
IMP-075-20	5/16"	X	4"	MAG. POWER	5
IMP-085-20	5/16"	X	6"	MAG. POWER	5
IMP-042-24	3/8"	X	1-3/4"	MAG. POWER	10
IMP-065-24	3/8"	X	2-9/16"	MAG. POWER	10
IMP-075-24	3/8"	X	4"	MAG. POWER	5
IMP-085-24	3/8"	X	6"	MAG. POWER	5
IMP-065-40	9/16"	X	2-9/16"	MAG. POWER	10
IMP-085-40	9/16"	X	6"	MAG. POWER	5

Nut Setters - Magnetic (Standard)

Part #	Hex Head Size	X	OAL	Type	Qty.
NS-042-16	1/4"	X	1-3/4"	MAG. NUT SETTER	10
NS-053-16	1/4"	X	2-1/8"	MAG. NUT SETTER	10
NS-065-16	1/4"	X	2-9/16"	MAG. NUT SETTER	10
NS-075-16	1/4"	X	4"	MAG. NUT SETTER	5
NS-085-16	1/4"	X	6"	MAG. NUT SETTER	5
NS-042-20	5/16"	X	1-3/4"	MAG. NUT SETTER	10
NS-053-20	5/16"	X	2-1/8"	MAG. NUT SETTER	10
NS-065-20	5/16"	X	2-9/16"	MAG. NUT SETTER	10
NS-075-20	5/16"	X	4"	MAG. NUT SETTER	5
NS-085-20	5/16"	X	6"	MAG. NUT SETTER	5
NS-042-24	3/8"	X	1-3/4"	MAG. NUT SETTER	10
NS-053-24	3/8"	X	2-1/8"	MAG. NUT SETTER	10
NS-065-24	3/8"	X	2-9/16"	MAG. NUT SETTER	10
NS-075-24	3/8"	X	4"	MAG. NUT SETTER	5
NS-085-24	3/8"	X	6"	MAG. NUT SETTER	5
NS-042-28	7/16"	X	1-3/4"	MAG. NUT SETTER	5
NS-053-28	7/16"	X	2-1/8"	MAG. NUT SETTER	5
NS-065-28	7/16"	X	2-9/16"	MAG. NUT SETTER	5
NS-042-32	1/2"	X	1-3/4"	MAG. NUT SETTER	5
NS-065-32	1/2"	X	2-9/16"	MAG. NUT SETTER	5

1000+

SCREW GUARANTEE

- ◆ 1/4" Hex Impact Shank
- ◆ Made for Powerful Impact Drivers / Wrenches
- ◆ 1pc Construction
- ◆ Industrial Grade Magnet



- ◆ 1/4" Hex Impact Shank
- ◆ 1pc Construction
- ◆ Industrial Grade Magnet

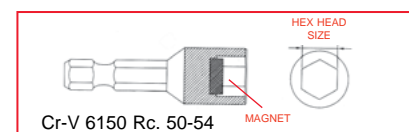



COMES WITH CASE AND HANDLE!



30 Pc. Screwdriver Insert Set - STANDARD

Part #	Description
ST-100-30	<ul style="list-style-type: none"> ⊕ Phillips: #1, #2, #3 ⊖ Slotted: 3-4, 4-5, 6-8, 8-10 ⊕ Posidriv: #1, #2, #3 ⊖ Square: #0, #1, #2, #3 ⊖ Hex: 5/64", 3/32", 7/64", 1/8", 9/64" ⊖ Star: T10, T15, T20, T25, T27, T30, T40 • 1" Long Socket Adaptor • 3" Long Bit Holder

COMES WITH CASE AND HANDLE!



30 Pc. Screwdriver Insert Set - TAMPER PROOF

Part #	Description
TR-100-30	<ul style="list-style-type: none"> ⊕ Spanner: #6, #8, #10 ⊕ Posidriv: #1, #2, #3 ⊖ Tri-Wing: #1, #2, #3 ⊖ Hex Tamper: 3/32", 1/8", 9/64", 5/32", 3/16", 7/32", 1/4", 5/16" ⊖ Star Tamper: T8, T9, T10, T15, T20, T25, T27, T30, T40 • 1" Long Socket Adaptor • 3" Long Bit Holder



32 Pc. Screwdriver Insert Set - STANDARD

Part #	Description
TECH-32	<ul style="list-style-type: none"> ⊕ Phillips: #0, #1, #2 (2), #3, #2DW (2) ⊖ Slotted: 6-8, 8-10, 10-12 ⊖ Square: #0, #1, #2 (3), #3 ⊖ Hex: 5/64", 3/32", 7/64", 1/8", 5/32", 3/16" ⊖ Star: T8, T10, T15, T20, T25, T27, T30, T40 • 1/4" Impact Driver Adaptor • 1/4" Auto Locking Magnetic Bit Holder



← Belt Clip



32 Pc. Screwdriver Insert Set - TAMPER PROOF

Part #	Description
TECH-32TR	<ul style="list-style-type: none"> ⊕ Spanner: #6, #8, #10, #12, #14 ⊖ Star Tamper: T8, T9, T10, T15, T20, T25, T27, T30, T40 ⊖ Hex Tamper: 3/32", 1/8", 9/64", 5/32", 3/16", 7/32", 1/4", 5/16" ⊖ Tri-Wing: #1, #2, #3 ⊖ Square: #1, #2, #3 ⊕ Phillips: #2, #3 • 1/4" Impact Driver Adaptor • 1/4" Auto Locking Magnetic Bit Holder

US PATENT 5265504

Made In

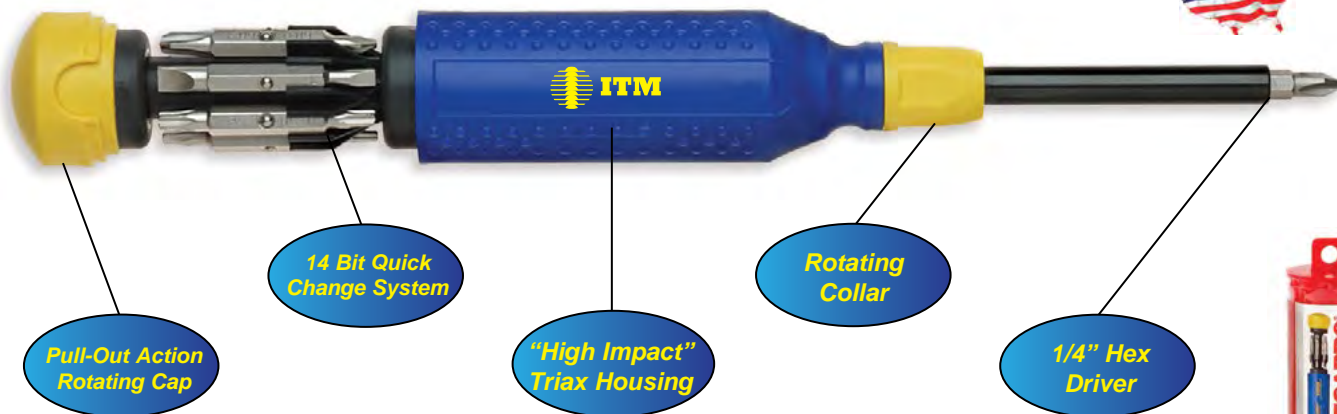

15 in 1
SCREWDRIVER

MEGAPRO®



Tamper Proof Tamper Proof Driver sold Individually Tubed.

Part #	Description
MEGAPRO151	15-IN-1 MEGAPRO SCREWDRIVER #0 - #3 PHILLIPS #10 - #15 STAR #1 - #2 PHILLIPS #20 - #25 STAR #0 - #3 SQUARE #4 - #6 SLOTTED #1 - #2 SQUARE

Part #	Description
MEGATAM151	15-IN-1 TAMPERPROOF SCREWDRIVER #6 - #8 SPANNER #10 - #15 STAR PIN #10 - #12 SPANNER #20 - #25 STAR PIN 1/8" - 9/64" HEX PIN #27 - #30 STAR PIN 5/32" - 3/16" HEX PIN

Part #	Description
470001	#0 - #3 PHILLIPS®
470002	#1 - #2 PHILLIPS®
470003	#0 - #3 SQUARE
470004	#1 - #2 SQUARE
470005	#10 - #15 STAR
470006	#20 - #25 STAR
470009	#27 - #30 STAR (SPECIAL SIZE)
470007	#4 - #6 SLOTTED
690001	#6 - #8 SPANNER
690002	#10 - #12 SPANNER
690003	1/8" - 9/64" HEX PIN
690004	5/32" - 3/16" HEX PIN
690005	#10 - #15 STAR PIN
690006	#20 - #25 STAR PIN
690007	#27 - #30 STAR PIN

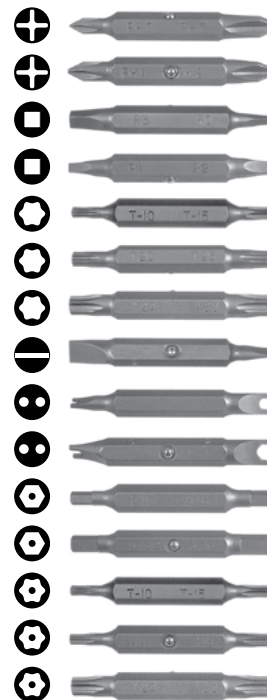

Replacement bits for the Megapro & Megapro Tamper Proof are sold individually.

**NATURAL NYLON 6.6 CABLE TIES**

- ◆ Manufactured of 100% Nylon
- ◆ Non-Corrosive
- ◆ Specification: Type 6.6 Nylon
- ◆ Self-Extinguishing
- ◆ Natural & Weather Resistant Black
- ◆ Operating Temperatures From 40° F (-40° C) to 185° F (85° C).
- ◆ Recognized Under the Components Program of Underwriter Laboratories, Inc.

Part #	Length	Tensile Strength	Width	Bundle Diameter	Military Specification	Pack Qty.	
MS0016-C	4"	18 lbs.	3/32"	1/16" → 5/8"	MS-3367-4-9	100	
MS0032-C	5.5"	40 lbs.	1/8"	1/16" → 1-1/4"	MS-3367-5-9	100	
MS0050-C	8"	50 lbs.	3/16"	1/16" → 2-1/8"	MS-3367-1-9	100	
MS0070-C	11"	50 lbs.	3/16"	1/16" → 3"	MS-3367-7-9	100	
MS0108-C	15"	50 lbs.	3/16"	1/16" → 4"	MS-3367-2-9	100	

NATURAL NYLON 6.6 CABLE TIES - EXTRA HEAVY DUTY

Part #	Length	Tensile Strength	Width	Bundle Diameter	Military Specification	Pack Qty.	
XMS0050	8"	120 lbs.	5/16"	3/16" → 2"	-	100	
XMS0070	11"	120 lbs.	5/16"	3/16" → 3"	-	100	
XMS0108	15"	120 lbs.	5/16"	3/16" → 4"	-	100	
XMS0152	24"	175 lbs.	3/8"	3/16" → 7"	-	100	
XMS0225	36"	175 lbs.	3/8"	3/16" → 10"	-	100	
XMS0300	48"	175 lbs.	3/8"	3/16" → 12"	-	100	

File # E 57800.

**BLACK WEATHER RESISTANT NYLON CABLE TIES**

Part #	Length	Tensile Strength	Width	Bundle Diameter	Military Specification	Pack Qty.	
BWR0016-C	4"	18 lbs.	3/32"	1/16" → 5/8"	MS-3367-4-0	100	
BWR0032-C	5.5"	40 lbs.	1/8"	1/16" → 1-1/4"	MS-3367-5-0	100	
BWR0050-C	8"	50 lbs.	3/16"	1/16" → 2-1/8"	MS-3367-1-0	100	
BWR0070-C	11"	50 lbs.	3/16"	1/16" → 3"	MS-3367-7-0	100	
BWR0108-C	15"	50 lbs.	3/16"	1/16" → 4"	MS-3367-2-0	100	

BLACK WEATHER RESISTANT NYLON CABLE TIES - EXTRA H.D.

Part #	Length	Tensile Strength	Width	Bundle Diameter	Military Specification	Pack Qty.	
XBWR050	8"	120 lbs.	5/16"	3/16" → 2"	-	100	
XBWR070	11"	120 lbs.	5/16"	3/16" → 3"	-	100	
XBWR108	15"	120 lbs.	5/16"	3/16" → 4"	-	100	
XBWR152	24"	175 lbs.	3/8"	3/16" → 7"	-	100	
XBWR225	36"	175 lbs.	3/8"	3/16" → 10"	-	100	
XBWR300	48"	175 lbs.	3/8"	3/16" → 12"	-	100	

**CABLE TIE WITH SCREW MOUNT HOLE**

Part #	Length	Tensile Strength	Width	Bundle Diameter		Pack Qty.	
NATURAL							
WCM0050	8"	50 lbs.	3/16"	1/16" → 2-1/8"	-	100	
WCM0070	11"	50 lbs.	3/16"	1/16" → 3"	-	100	
WCM0108	14"	50 lbs.	3/16"	1/16" → 4"	-	100	
BLACK							
BCM0050	8"	50 lbs.	3/16"	1/16" → 2-1/8"	-	100	
BCM0070	11"	50 lbs.	3/16"	1/16" → 3"	-	100	
BCM0108	14"	50 lbs.	3/16"	1/16" → 4"	-	100	



CONICAL ANCHOR - BLUE



SUPER ANCHOR - YELLOW



ZAP-IN ANCHOR (ZINC)



ZAP-IN ANCHOR (NYLON)

PART# 807AK0010
 100 pcs. - 3/16" Conical Anchors
 100 pcs. - #8 x 1" Combo Screws
 1 pc. - 3/16" x 4" Hammer Drill

PART# SUPRAK006
 100 pcs. - 3/16" SUPER Anchors
 100 pcs. - #8 x 1" Combo Screws
 1 pc. - 3/16" x 4" Hammer Drill

PART# EZZ-PACK
 50 pcs. - Zinc Zap-In
 50 pcs. - #8 x 1" Combo Screws
 1 pc. - #2 x 2" Phillips Bit

PART# EZN-PACK
 50 pcs. - Plastic Zap-In
 50 pcs. - #8 x 1" Combo Screws
 1 pc. - #2 x 2" Phillips Bit

PART# 807AK0011
 100 pcs. - 1/4" Conical Anchors
 100 pcs. - #10 x 1 1/4" Combo Screws
 1 pc. - 1/4" x 4" Hammer Drill

PART# SUPRAK008
 100 pcs. - 1/4" SUPER Anchors
 100 pcs. - #10 x 1 1/4" Combo Screws
 1 pc. - 1/4" x 4" Hammer Drill

PART# 807AK0013
 50 pcs. - 5/16" Conical Anchors
 50 pcs. - #12 x 1 1/2" Combo Screws
 1 pc. - 5/16" x 4" Hammer Drill

PART# SUPRAK009
 50 pcs. - 5/16" SUPER Anchors
 50 pcs. - #12 x 1 1/2" Combo Screws
 1 pc. - 5/16" x 4" Hammer Drill



COMBO SCREW



Anchor Kits

SOLD IN A MASTER BOX OF 10 KITS.



ZAP-IN Anchors

Part #	OAL	Description	Box Qty.	Packaged	List / C
EZZ1212	1-5/16"	ZAP IN ZINC ALLOY	100	BOX	
EZZ1212B	1-5/16"	ZAP IN ZINC ALLOY	2,000	BULK	
EZN1212	1-3/4"	ZAP IN NYLON	100	BOX	
EZN1212B	1-3/4"	ZAP IN NYLON	2,000	BULK	



- ◆ Industrial Quality
- ◆ Ideal for Fastening to Drywall and Other Low Density Substrates
- ◆ Easily Removable by Simply Backing Out Screw



INTERNATIONAL TOOL MANUFACTURING
150 Express St. Plainview, NY 11803

(516) 738-0388 • (800) 247-5696

ITM® Fax (516) 279-1106

- ◆ Retractable 3 Blade Positions
- ◆ Extra Blade Inside Compartment
- ◆ Carded and Sold Individually



- ◆ Retractable 3 Blade Positions
- ◆ 3 Blades In Each Knife
- ◆ Heavy Duty Die Cast Aluminum
- ◆ Pull Out Mechanism For Quick Blade Change

FREE COUNTER DISPLAY WITH EVERY ORDER.



Carded Utility Knife - 1 Pack

Part #	Description
UTK0001	UTILITY KNIFE

Quick Release Utility Knife - 12 Pack

Part #	Description
UTK0002	UTILITY KNIFE (12 PK)

- ◆ Double Sided Tooth Geometry
- ◆ Narrow Blade Ideal For Awkward Cuts
- ◆ Carded And Sold Individually



- ◆ 6 in 1 Quick Change
- ◆ Industrial Quality

SOLD IN 12 PIECE DISPLAY BOX ONLY.



6" Wallboard Saw - 1 Pack

Part #	Description
WS-6	6" WALLBOARD SAW

6-IN-1 Combination Screwdriver

Part #	Description
ST-100-20	6-IN-1 SCREWDRIVER #1, #2, PHILLIPS 1/4" NUT SETTER #5, #8-10, SLOTTED 5/16" NUT SETTER

- ◆ Heavy Duty
- ◆ Fits All Standard Knives
- ◆ Made in Taiwan



Heavy Duty Utility Blades

Part #	Description	Qty.
HDB9005	INDIVIDUAL PACK	5
HDB9100	100 PACK (20 X 5 PACKS)	100
HDB9100-HOOK	100 PACK - DOUBLE HOOK	100

Safety Goggles

Part #	Description	Qty.
GOG0001	SAFETY GOGGLES	1

RETAIL READY DISPLAYS



Part #	Size	Qty.
XSTP-01	13 Step - 1/8"-1/2"	3
XSTP-02	6 Step - 3/16"-1/2"	3
XSTP-03	9 Step - 1/4"-3/4"	3
XSTP-04	12 Step - 3/16"-7/8"	3
XSTP-05	12 Step - 7/16"-1-1/8"	3
XSTP-08	2 Step - 7/8"-1-1/8"	3

RACK6
7"Out X 15"H X 7"W



X-FLUTE Step Drill

Part #	Contents
--------	----------

- RACK6 Black Header - 6 Prong
- H-11 X-FLUTE Header
- DIS-XF X-FLUTE Step Bits



P. 41



VG-4001B	1/8" X 3"- 25 PC.	2
VG-4002B	3/16" X 4" - 25 PC.	2
VG-4003B	1/4" X 4" - 25 PC.	2
VG-6001B	3/16" X 6" - 25 PC.	2
VG-6002B	1/4" X 6" - 25 PC.	2
VG-4002	3/16" X 4"	25
VG-4003	1/4" X 4"	25
VG-6001	3/16" X 6"	25
VG-6002	1/4" X 6"	25
VG-6003	5/16" X 6"	10
VG-6004	3/8" X 6"	5
VG-6005	1/2" X 6"	5

RACK12



V GROOVE Tile Bit

Part #	Contents
--------	----------

- RACK12 Black Header - 12 Prong
- H-2 V GROOVE Header
- DIS-VG V GROOVE Tile Bits



P. 74



HEX-12	3/16" X 2-5/8"	10
HEX-14	1/4" X 2-5/8"	10
HEX-16	5/16" X 3-1/8"	6
HEX-18	3/8" X 3-1/8"	6
HEX-20	1/2" X 3-1/8"	6
HEX-22	5/8" X 2-3/4"	5
HEX-24	3/4" X 2-3/4"	5
HEX-26	7/8" X 2-3/4"	5
HEX-28	1" X 2-3/4"	5

RACK30
7"Out X 8"H X 23"W



White Diamond Tile - Hex

Part #	Contents
--------	----------

- RACK30 Black Header - 9 Prong
- H-8 White Diamond Header
- DIS-WD9 White Diamond - HEX



P. 76



HEX-12	3/16" X 2-5/8"	10
HEX-14	1/4" X 2-5/8"	10
HEX-16	5/16" X 3-1/8"	6
HEX-18	3/8" X 3-1/8"	6
HEX-20	1/2" X 3-1/8"	6
HEX-22	5/8" X 2-3/4"	5
HEX-24	3/4" X 2-3/4"	5
HEX-26	7/8" X 2-3/4"	5
HEX-28	1" X 2-3/4"	5
ANG-26	7/8" X 2-3/8"	5
ANG-28	1" X 2-3/8"	5
ANG-30	1-1/8" X 2-3/8"	3
ANG-32	1-1/4" X 2-3/8"	3
ANG-34	1-3/8" X 2-3/8"	3
ANG-36	1-1/2" X 2-3/8"	3
ANG-38	2" X 2-3/8"	3
ANG-40	2-1/2" X 2-3/8"	3
PAD-5811	ADAPTER 5/8"-11	6

RACK35
7"Out X 23"H X 23"W



White Diamond Tile - Full

Part #	Contents
--------	----------

- RACK35 Black Header - 19 Prong
- H-8 White Diamond Header
- DIS-WD19 White Diamond - HEX & Angle



P. 76



INTERNATIONAL TOOL MANUFACTURING
150 Express St. Plainview, NY 11803

(516) 738-0388 • (800) 247-5696

ITM® Fax (516) 279-1106

Part #	Size	Qty.
--------	------	------



255H04	1/16" X 1-7/8"	12
255H06	3/32" X 2-1/4"	12
255H08	1/8" X 2-3/4"	12
255H10	5/32" X 3-1/8"	12
255H12	3/16" X 3-1/2"	12
255H14	7/32" X 3-3/4"	12
255H16	1/4" X 4"	12
255H18	9/32" X 4-1/4"	12
255H20	5/16" X 4-1/2"	12
255H24	3/8" X 5"	12
255H28	7/16" X 5-1/2"	6
255H32	1/2" X 6"	6



1/4" Hex Titanium Jobbers

Part #	Contents
RACK12	Black Header - 12 Prong
H-3	HEX Titanium Header
DIS-THEX	HEX Titanium Jobber Drills

TITANIUM NITRIDE P. 24



HF0016	7/8" (3/16" Depth)	2
HF0019	1-1/8" (3/16" Depth)	2
HF0023	1-3/8" (3/16" Depth)	2
HG0016	7/8" (1/2" Depth)	2
HG0019	1-1/8" (1/2" Depth)	2
HG0023	1-3/8" (1/2" Depth)	2
HM0016	7/8" (1-3/8" Depth)	2
HM0019	1-1/8" (1-3/8" Depth)	2
HM0023	1-3/8" (1-3/8" Depth)	2



T.C.T. Hole Cutter

Part #	Contents
RACK12	Black Header - 12 Prong
H-7	TCT Hole Cutter Header
DIS-TCT	TCT Hole Cutters

TUNGSTEN CARBIDE P. 48-49



W636	6" X 6T	3
W956	9" X 6T	3
W125	12" X 6T	3
M1218	12" X 18T	3
M810	8" X 10T	3
M814	8" X 14T	3
M818	8" X 18T	3
M614	6" X 14T	3
M618	6" X 18T	3
M624	6" X 24T	3



Reciprocating Blades

Part #	Contents
RACK10	Red Header - 10 Prong
H-10	Reciprocating Blade Header
DIS-RECP	Reciprocating Blades

RACK10
3"Out X 8"H X 12"W

BI-METAL 8% COBALT P. 58



RACK12
7"Out X 8"H X 24"W
1/4" Metal Wire



RACK18
15"Out X 8"H X 24"W
1/4" Metal Wire



- ◆ Heavy Duty
- ◆ Black Oxide Finish



All individually packed **ITM** drill bits have barcode and can be hung on this display. Simple and hassle free.

ITM Displays - Empty

Part #	Rack
RACK10	Reciprocating Blade
RACK12	Top Header
RACK18	Bottom Extra
RACK20	Oscillating Blade
RACK30	White Diamond - Hex Only
RACK35	White Diamond - Hex & Grinder
H-1	Anything That Makes a Hole Header



SDS-Plus - Redline

Part #	Contents
RACK12	Black Header - 12 Prong
H-4	SDS Redline Header
DIS-REDL	SDS Redline Bits - Starter



RL-41264	3/16" X 4-1/4"	10
RL-61264	3/16" X 6-1/4"	10
RL-41664	1/4" X 4-1/4"	10
RL-61664	1/4" X 6-1/4"	10
RL-62464	3/8" X 6-1/4"	10
RL-12038	3/8" X 12-1/4"	10
RL-63264	1/2" X 6-1/4"	10
RL-12012	1/2" X 12-1/4"	10
RL-84064	5/8" X 8-1/4"	10
RL-84864	3/4" X 8"	5
RL-85664	7/8" X 8"	5
RL-10001	1" X 10"	5



SDS-Plus - Bohr Hammer

Part #	Contents
RACK12	Black Header - 12 Prong
H-5	SDS Bohr Hammer Header
DIS-BOHR	SDS Bohr Hammer Bits - Starter

BOHR HAMMER STARTER - P. 82-83

715S41264	3/16" X 4-1/4"	10
715S61264	3/16" X 6-1/4"	10
715S41664	1/4" X 4-1/4"	10
715S61664	1/4" X 6-1/4"	10
715S62464	3/8" X 6-1/4"	10
715S82464	3/8" X 8-1/4"	10
715S63264	1/2" X 6-1/4"	10
715S12012	1/2" X 12-1/4"	10
715S84064	5/8" X 8-1/4"	5
715S84864	3/4" X 8"	5
715S85664	7/8" X 8"	5
715S10001	1" X 10"	5



SDS-Plus - Bohr Hammer

Part #	Contents
RACK12	Black Header - 12 Prong
H-5	SDS Bohr Hammer Header
DIS-B12S	SDS Bohr Hammer Bits - Short

BOHR HAMMER SHORT - P. 82-83

715S61064	5/32" X 6-1/4"	10
715S61264	3/16" X 6-1/4"	10
715S81264	3/16" X 8-1/4"	10
715S41664	1/4" X 4-1/4"	10
715S61664	1/4" X 6-1/4"	10
715S81664	1/4" X 8-1/4"	10
715S62064	5/16" X 6-1/4"	10
715S62464	3/8" X 6-1/4"	10
715S63264	1/2" X 6-1/4"	5
715S10012	1/2" X 10-1/4"	5
715S84064	5/8" X 8"	5
715S84864	3/4" X 8"	5



SDS-Plus - Bohr Hammer

Part #	Contents
RACK12	Black Header - 12 Prong
H-5	SDS Bohr Hammer Header
DIS-B12L	SDS Bohr Hammer Bits - Long

BOHR HAMMER LONG - P. 82-83

715S10316	3/16" X 10-1/4"	6
715S12316	3/16" X 12-1/4"	6
715S10014	1/4" X 10-1/4"	6
715S14014	1/4" X 14"	6
715S82464	3/8" X 8-1/4"	6
715S12038	3/8" X 12-1/4"	6
715S18038	3/8" X 18"	6
715S12012	1/2" X 12-1/4"	6
715S12058	5/8" X 12-1/4"	3
715S12034	3/4" X 12"	3
715S12078	7/8" X 12"	3
715S18001	1" X 18"	3



SDS-Plus - X Cutter

Part #	Contents
RACK12	Black Header - 12 Prong
H-6	SDS X Cutter Header
DIS-EVO	SDS X Cutter Bits - Starter

XCUTTER STARTER - P. 86

EVL41264	3/16" X 4-1/2"	10
EVL61264	3/16" X 6-1/2"	10
EVL81264	3/16" X 8-1/2"	10
EVL41664	1/4" X 4-1/2"	10
EVL61664	1/4" X 6-1/2"	10
EVL81664	1/4" X 8-1/2"	10
EVL62064	5/16" X 6-1/2"	10
EVL62464	3/8" X 6-1/4"	10
EVL12038	3/8" X 12-1/4"	10
EVL63264	1/2" X 6-1/4"	10
EVL12012	1/2" X 12-1/4"	5





PRIVATE LABELING ON ALL ROTARY HAMMER DRILLS



LET US BRING YOUR BRAND TO THE CUSTOMER.

